



Solar HVAC 230V | Model "Z" 5-Ton Residential Unit

Part Number

SHRGZ- 60 0 5 00 A 910 11 - G*

Type (1)

G - Gas**

BTU's (23)

60 - 60,000 BTUs

Fan (4)

0 - No Fan

Voltage (5)

G - 230 VAC 1Φ
H - 230VAC 3Φ

Gas Heat**
(6,7)

00 - No Heat

Heat
Stages (8)

A - No Controls

Disconnect (9,10)

00 - No Disconnect
01 - 240V - 30A Fuse
11 - 240V - 30A Switch

Configuration (11)

0 - Condenser Only
*A - Down Supply / Down Return
*D - Horizontal Supply / Horizontal Return

Options (12)

0 - No Options
*B - Whole Unit (UG)
*C - All Coils (UG)
D - Condenser Coil (UG)
G - Model 'A' AHU (A-Coil)
*K - DW w/ Poly Insulation
*N - Dirty Filter Switch
Y - Start Up
*3 - Condensate Flow Switch
7 - Phase Monitor
*8 - Ionization Installed in AHU

* - Only available when "G - Model 'A' AHU (A-Coil)" is selected in (Options (12))

** - Customer Supplied Gas Heater (Only A-Coil Supplied)

Description

A Solar HVAC Residential Unit is more than twice as efficient as a standard residential split unit.

A solar box equipped with chambers lined with specialty reflective film is mounted to the top of the condensing unit. Through a patented process, ambient light is converted to thermal energy which reduces the energy demand on the compressor.

The highest efficiency condensing unit (made with the patented so-lar HVAC system) paired with a Model "A" A-Coil Unit that is intended to be added to a customer supplied gas heater.

Units come with a 1-year parts warranty and 10 year compressor warranty.

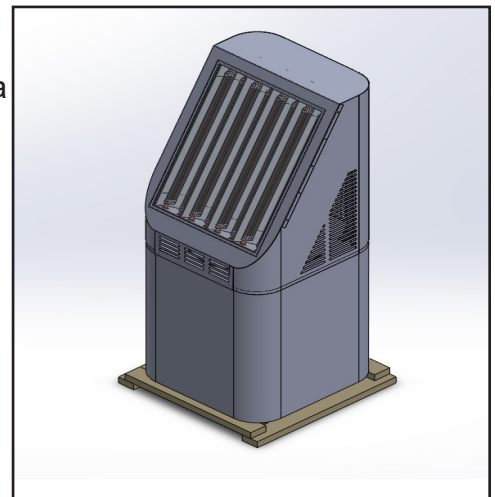



Dimensions

SHRDZ-60 | Solar HVAC Model "Z" Residential Condenser Dimensions

Model		SHRDZ-60 (5 Ton)	
Code	Outdoor Code		
Outdoor Power Supply	V/Hz		208-230V/60Hz
Cooling	Capacity	Btu/h	56000
		W	5185
	EER	Btu/h, W	10.8
	SEER		17.5
Compressor	Type		Twin-rotary DC
Outdoor Dimension	Packing (WxHxD)	Inch	32-5/8 x 32-5/8 x 79-5/8

(Outdoor Unit) Model		SHRDZ-60 (5 Ton)	
Outdoor Weight	Net - Lbs (kg)		301 (137)
	*Gross - Lbs (kg)		306 (139)
Electrical Data 208/230 1φ	Minimum Circuit Ampacity		36.5 A
	Max. Overcurrent Protection		60 A
Electrical Data 208/230 3φ	Minimum Circuit Ampacity		21.09 A
	Max. Overcurrent Protection		30 A
Outdoor Noise Level (dB(A))			79
Operation Temperatures (°F)			5 - 118

Note:
 Unit should be UL 1995 listed
 Unit should be OG-100 Certified to the Solar certification on ICC901/SRCC100
Note: Face solar panels south for optimal performance.

* Gross = Net Weight + Shipping Box

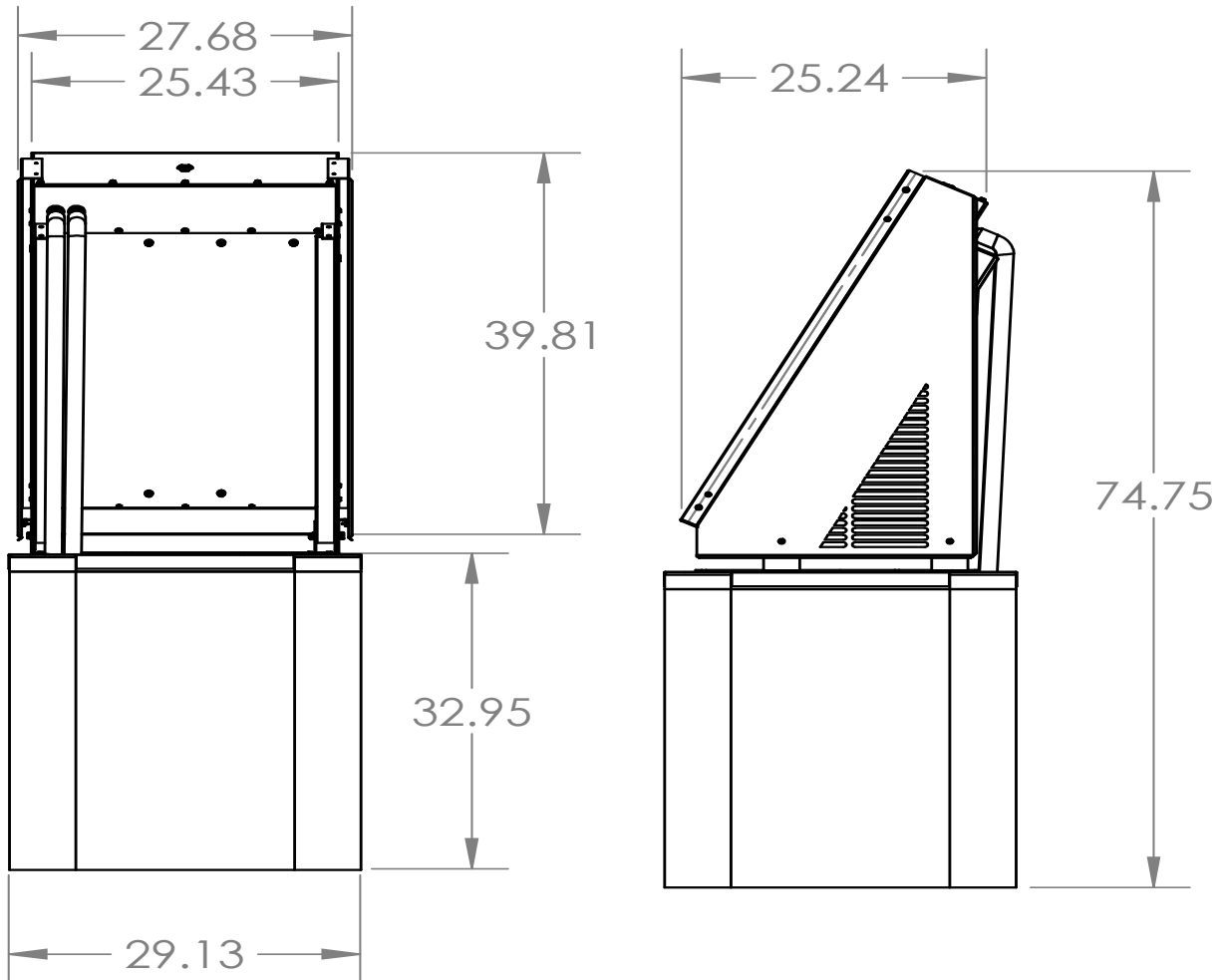

SHR*-** Clearances | v 2.00 | 05/20/22

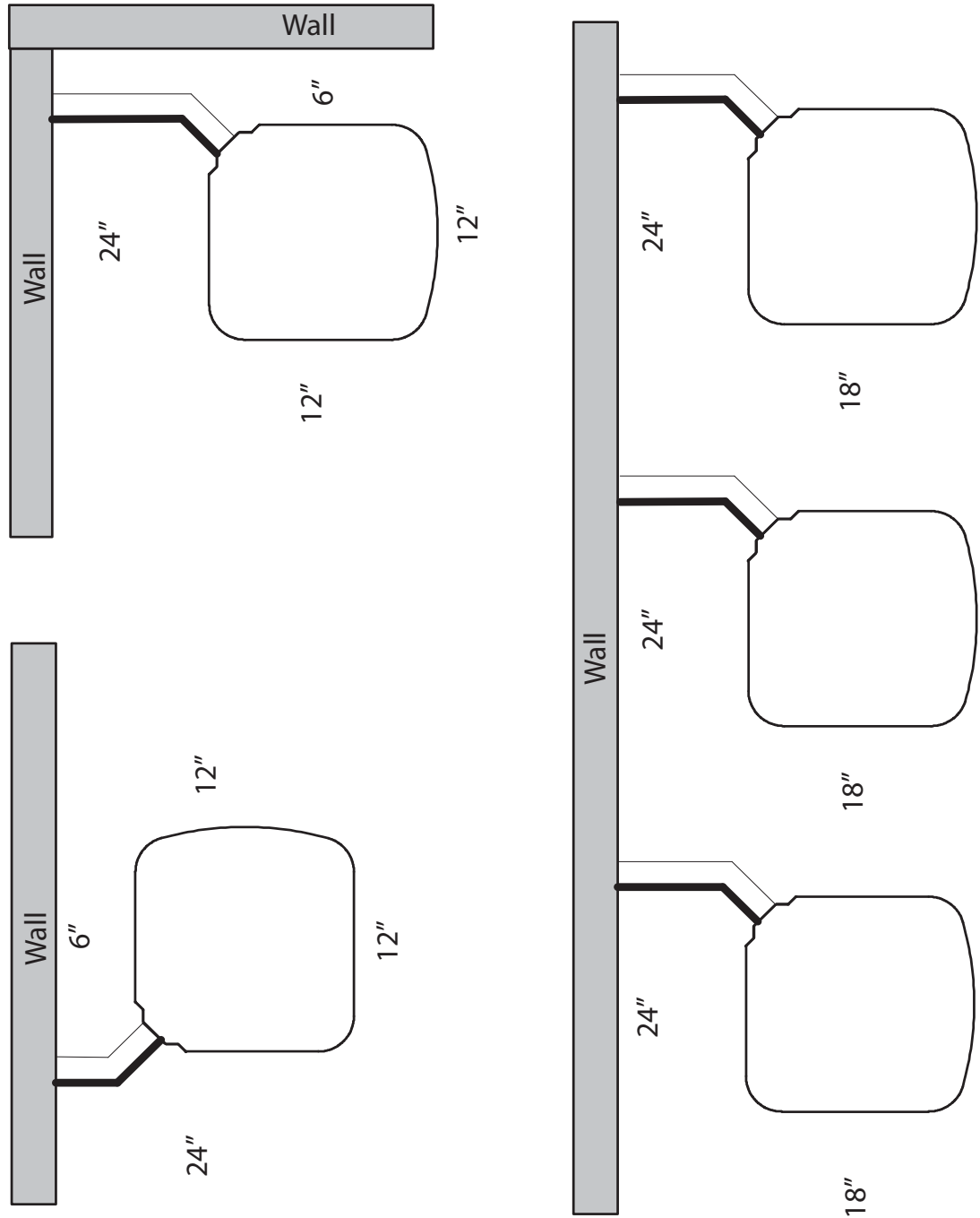

* - Unit Type Gas (G)

** - BTU's - x 1000 (24, 36, 48, 60)



Specifications and Dimensions

SHRDZ-60-ZERO | Solar HVAC Model "A" A-Coil Dimensions

Evap Coil Specs.	Type	Puron Refrigerant	Nominal Cooling Capacity	CFM	Ext. Static Pressure	Indoor Noise Level
	Inner Groove	TXV	56,000	1750	0.20	68

Zero 60k AHU Dimensions								
Supply Duct "A"	Supply Duct "B"	Length "D"	Width "W"	Height "H"	Return Duct "X"	Return Duct "Y"	Filter "Z"	Filter "F"
19.5"	10.5"	24.5"	22"	26.5"	18.8"	23"	20.7"	1"
[495mm]	[267mm]	[622mm]	[559mm]	[673mm]	[478mm]	[584mm]	[526mm]	[25mm]

A-Coil Dimensions		
Liquid Line	Vapor Line	Filter Size
3/8"	7/8"	20.5" x 23.8"
[9.5mm]	[22mm]	[521mm x 605mm]

Shipping Weight	Shipping Dimensions
70 lbs	25" x 22.75" x 23"
32 kg	635 x 578 x 584 mm

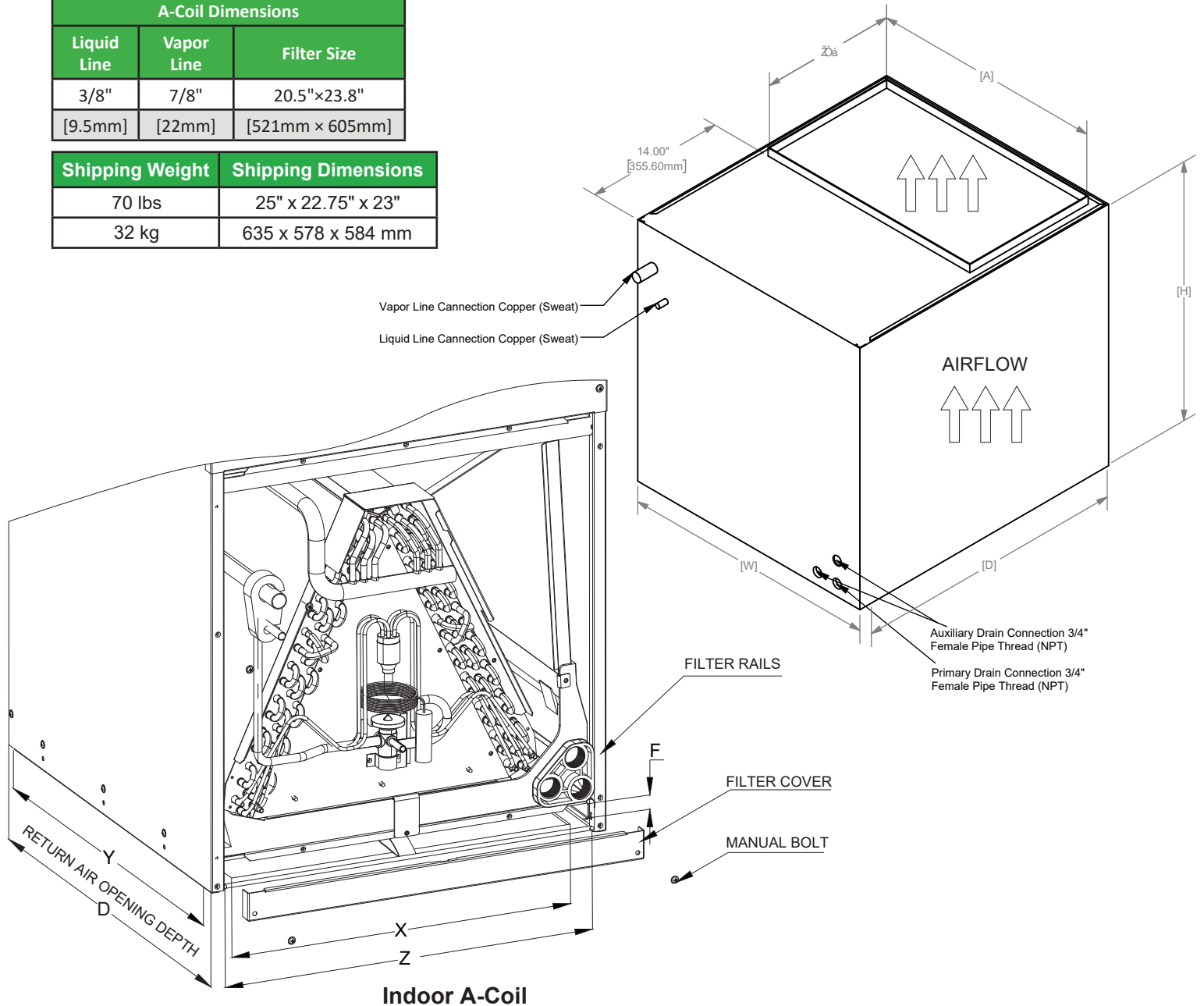

Indoor A-Coil

SHRDZ-60-ZERO | Solar HVAC Model "A" A-Coil Clearances

SHR*-A-Coil AHU Clearances | v 1.00 | 07/22/24

