

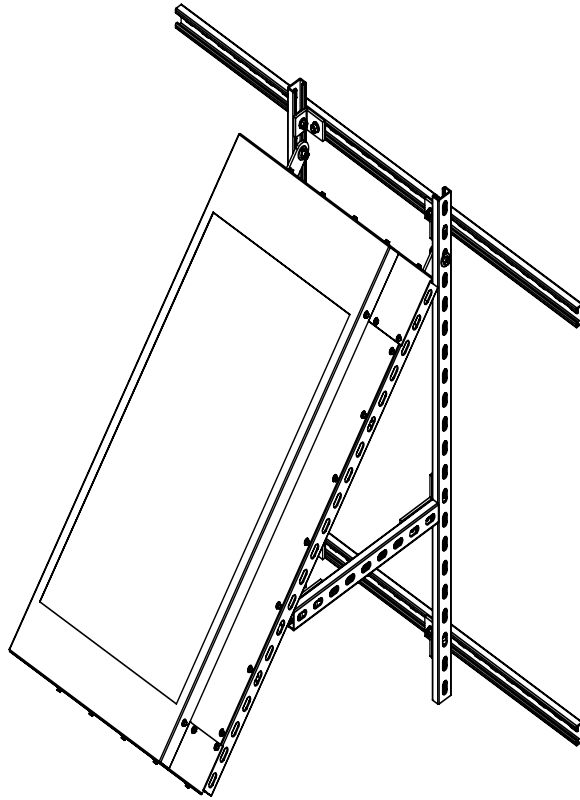

**Solar HVAC
Commercial Kit and
Mounting Assemblies
I/O/M manual**

Shown Assembled with Solar Box



NOTE: Appearance of unit may vary.

All phases of this installation must comply with NATIONAL, STATE AND LOCAL CODES.

IMPORTANT: This Document is customer property and is to remain with this unit. Please return to service information pack upon completion of work.

These instructions do not cover all variations in system or provide for every possible contingency to be met in connection with the installation. Should further information be desired or should particular problems arise which are not covered sufficiently for the purchaser's purposes, the matter should be referred to your installing dealer or local distributor.

The system is designed to be used with R410A Refrigerant and sized per the tonnage of refrigeration circuit. Some measuring, cutting, and fitting will need to be completed to fit it on a specific HVAC Unit.

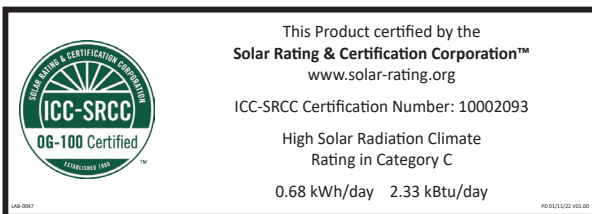

This product manufactured under the following patents:

US Patent #9,810,455
 US Patent #10,982,862
 US Patent #10,900,694
 US Patent #11,143,437
 and patents pending.

www.myiaire.com

PRT-0035 V01.00

Table of Contents

General Description	2
Safety Information	4
Commercial Complete Unit Kit Part Number and Description	5
Mounting Kit Part Number Scheme and Description	6
General Assembly Instructions - Commercial Unit Mount	7
General Assembly Instructions - Commercial Package Unit Mount	8
General Assembly Instructions - Commercial Package Unit Mount	9
General Assembly Instructions - Commercial Split Mount	10
Heat Pump (Liquid) Piping Diagram	11
Heat Pump - (Liquid) Single Circuit 2 Compressor Plumbing Diagram	12
DX Cool Gas (Liquid) Single Circuit 2 Compressor Plumbing Diagram	13
Cooling (Liquid) Gas Heat Plumbing Diagram.....	14
(Liquid) - 2xSolar Box [Parallel] - Cooling or Gas Plumbing Diagram	15
(Liquid) - 2xSolar Box [Parallel] - Single Circuit - Dual Compressor - Cool / Gas Plumbing Diagram.....	16
Solar Rack Plumbing Diagram - Multiple Variations	17 - 19
Tstat VFD Wiring Diagram	20
Compressor Driven VFD Parameters	21
Maintenance.....	22
Solar Box Dimensions (1.25 - 5.00 ton)	23
Solar Box Dimensions (7.50 - 15.0 ton)	24
Solar Mount Dimensions - Single Panel - 3.75 Tons	25
Solar Mount Dimensions - Single Panel - 5.00 Tons	26
Solar Mount Dimensions - Dual Panel - 7.50 Tons	27
Solar Mount Dimensions - Dual Panel - 10.0 Tons	28
Solar Mount Dimensions - Single Panel - 7.50 Tons	29
Solar Mount Dimensions - Dual Panel - 15.0 Tons	30
Solar Mount Dimensions - Single Panel - 10.0 Tons	31
Solar Mount Dimensions - Dual Panel - 20.0 Tons	32
Solar Mount Dimensions - Single Panel - 15.0 Tons	33
Solar Mount Dimensions - Dual Panel - 30.0 Tons	34
Solar Rack Part Number Scheme and Description	35
Solar Racks with Solar Boxes Shown	36 - 38
Solar Rack Dimensions - Dual Panel - 20 Tons	39
Solar Rack Dimensions - Dual Panel - 25 Tons	40
Solar Rack Dimensions - Dual Panel - 30 Tons	41
Solar Rack Dimensions - Triple Panel - 30 Tons.....	42
Solar Rack Dimensions - Triple Panel - 35 Tons.....	43
Solar Rack Dimensions - Triple Panel - 40 Tons.....	44
Solar Rack Dimensions - Triple Panel - 45 Tons.....	45
Solar Rack Dimensions - Quad Panel - 40 Tons	46
Solar Rack Dimensions - Quad Panel - 45 Tons	47
Solar Rack Dimensions - Quad Panel - 50 Tons	48
Solar Rack Dimensions - Quad Panel - 55 Tons	49
Solar Rack Dimensions - Quad Panel - 60 Tons	50
Appendix 1 - R410A Refrigerant Add.....	51
Appendix 2 - Solar Box Design Parameters & Liquid Line Specifications	52

Safety:

Important- This document contains a wiring diagram and service information. This is customer property and is to remain with this unit. Please return to service information pack upon completion of work.

 **CAUTION**

This information is intended for use by individuals possessing adequate backgrounds of electrical and mechanical experience. Any attempt to repair a central air conditioning product may result in personal injury and/or property damage. The manufacturer or seller cannot be responsible for the interpretation of this information, nor can it assume any liability in connection with its use.

 **WARNING**

HAZARDOUS VOLTAGE!

Failure to follow this warning could result in property damage, severe personal injury, or death. Disconnect all electric power, including remote disconnects before servicing. Follow proper lockout/tagout procedures to ensure the power cannot be inadvertently energized.

 **WARNING**

REFRIGERANT OIL!

Any attempt to repair a central air conditioning product may result in property damage, severe personal injury, or death.

These units use R-410A refrigerant which operates at 50 to 70% higher pressures than R-22. Use only R-410A approved service equipment. Refrigerant cylinders are painted a "Rose" color to indicate the type of refrigerant and may contain a "dip" tube to allow for charging of liquid refrigerant into the system. All R-410A systems with variable speed compressors use a PVE oil that readily absorbs moisture from the atmosphere. To limit this "hygroscopic" action, the system should remain sealed whenever possible. If a system has been open to the atmosphere for more than 4 hours, the compressor oil must be replaced. Never break a vacuum with air and always change the driers when opening the system for component replacement.

 **CAUTION**

HOT SURFACE!

May cause minor to severe burning. Failure to follow this Caution could result in property damage or personal injury. Do not touch top of compressor.

 **CAUTION**

CONTAINS REFRIGERANT!

Failure to follow proper procedures can result in personal illness or injury or severe equipment damage.

System contains oil and refrigerant under high pressure. Recover refrigerant to relieve pressure before opening system.

 **CAUTION**

GROUNDING REQUIRED!

Failure to inspect or use proper service tools may result in equipment damage or personal injury. Reconnect all grounding devices. All parts of this product that are capable of conducting electrical current are grounded. If grounding wires, screws, straps, clips, nuts, or washers used to complete a path to ground are removed for service, they must be returned to their original position and properly fastened.

 **WARNING**

SERVICE VALVES!

Failure to follow this warning will result in abrupt release of system charge and may result in personal injury and/or property damage. Extreme caution should be exercised when opening the Liquid Line Service valve. Turn valve stem counterclockwise only until the stem contacts the rolled edge. No torque is required.

 **WARNING**

BRAZING REQUIRED!

Failure to inspect lines or use proper service tools may result in equipment damage or personal injury. If using existing refrigerant lines make certain that all joints are brazed, not soldered.

 **WARNING**

HIGH LEAKAGE CURRENT!

Failure to follow this warning could result in property damage, severe personal injury, or death. Earth connection essential before connecting electrical supply.

Solar HVAC Commercial Complete Unit Kit Part Number Scheme

1KSH-2 3 4 5 6 7-8 9 10 11 12 13 14 15-16

NOTE: The "K" in the part number indicates a kit. The customer shall provide the HVAC unit.

Install Location (1)

F - Field Installed
P - Plant Installed
K - Customer Installed Kit
R - Solar Rack

Unit Type (2)

P - Package Unit
S - Split Unit
R - Refrigerant

Unit Tonnage (3)

02 - 2 Ton	17 - 17.5 Ton
03 - 3 Ton	20 - 20 Ton
04 - 4 Ton	25 - 25 Ton
05 - 5 Ton	30 - 30 Ton
06 - 6.25 Ton	35 - 35 Ton
07 - 7.5 Ton	40 - 40 Ton
10 - 10 Ton	50 - 50 Ton
12 - 12.5 Ton	60 - 60 Ton
15 - 15 Ton	## - ## Ton

of Circuits (4)

S - Single Circuit
D - Dual Circuits
T - Triple Circuits
Q - Quad Circuits

of Compressors (5)

0 - No VFD's Supplied
Total Compressor Qty (1 - 4)

Evap Coil Type (6)

F - Full
H - Half Split
Q - Quarter Split

Voltage (7)

0 - No VFD's Supplied
G - 230 VAC 1Φ
H - 230VAC 3Φ
K - 460VAC 3Φ
L - 575VAC 3Φ

Solar Box Type(s) (Circuit 1) (8)

A - 3.75 Ton Solar Box
B - 5.00 Ton Solar Box
C - 7.50 Ton Solar Box
D - 10.0 Ton Solar Box
E - 15.0 Ton Solar Box
F - 20.0 Ton Solar Box (2 x 10 ton)
G - 25.0 Ton Solar Box (10 ton + 15 ton)
H - 30.0 Ton Solar Box (2 x 15 ton)

Solar Box Type(s) (Circuit 1) (9)

Solar Box Qty (1 - 9)

Solar Box Type(s) (Circuit 2) (10)

A - 3.75 Ton Solar Box
B - 5.00 Ton Solar Box
C - 7.50 Ton Solar Box
D - 10.0 Ton Solar Box
E - 15.0 Ton Solar Box
F - 20.0 Ton Solar Box
G - 25.0 Ton Solar Box (10 ton + 15 ton)
H - 30.0 Ton Solar Box (2 x 15 ton)

Solar Box Type(s) (Circuit 2) (11)

Solar Box Qty (1 - 9)

Solar Box Type(s) (Circuit 3) (12)

A - 3.75 Ton Solar Box
B - 5.00 Ton Solar Box
C - 7.50 Ton Solar Box
D - 10.0 Ton Solar Box
E - 15.0 Ton Solar Box
F - 20.0 Ton Solar Box (2 x 10 ton)
G - 25.0 Ton Solar Box (10 ton + 15 ton)
H - 30.0 Ton Solar Box (2 x 15 ton)

Solar Box Type(s) (Circuit 3) (13)

Solar Box Qty (1 - 9)

Solar Box Type(s) (Circuit 4) (14)

A - 3.75 Ton Solar Box
B - 5.00 Ton Solar Box
C - 7.50 Ton Solar Box
D - 10.0 Ton Solar Box
E - 15.0 Ton Solar Box
F - 20.0 Ton Solar Box
G - 25.0 Ton Solar Box (10 ton + 15 ton)
H - 30.0 Ton Solar Box (2 x 15 ton)

Solar Box Type(s) (Circuit 4) (15)

Solar Box Qty (1 - 9)

Options (16)

A = No Warranty
B = No Plumbing Kit
C = No Mounting Kit
Z = Special

Solar HVAC Mounting Kit Part Number Scheme

Universal Solar Mounting Kit

SLR-MNT-xxC31.50-185042
 SLR-MNT-xxC31.50-185448
 SLR-MNT-xxC31.50-186052-2
 SLR-MNT-xxC31.50-186458-2
 SLR-MNT-xxC37.50-206052
 SLR-MNT-xxC37.50-209266-2
 SLR-MNT-xxC50.00-266458
 SLR-MNT-xxC50.00-269266-2
 SLR-MNT-xxC75.00-409266
 SLR-MNT-xxC75.00-409266-2

A Solar HVAC Mounting Kit allows mounting of Solar Boxes, in a sunny location, on the condensing side of any Package Rooftop Units up to 30-Tons or Commercial Split Rooftop Units up to 20-Tons.

The Solar Box(es) are sized for tonnage and number of circuits of the HVAC Unit and the paired frame is to be cut-to-size to fit any HVAC Unit. The solar box can be mounted at any position and angle. It is recommended to place the solar box below the top of the HVAC Unit, above the base rail of the HVAC Unit and in between 30 and 60 degrees. Contact Factory if outside the parameters of these recommendations to ensure proper operation.

Strut mounting frame and hardware only. All parts ship loose and are to be assembled in the field. Solar Boxes are ordered separately. Customer must provide their own lagging and plumbing hardware.

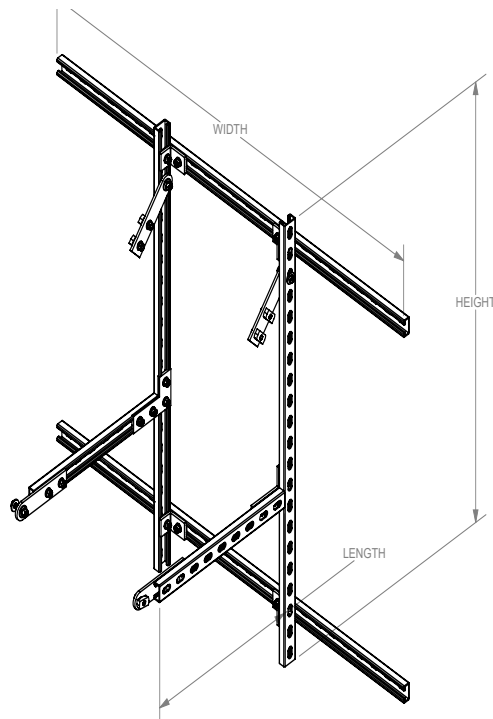

General Assembly Instructions - Commercial Unit

Generic Assembly Instructions

HVAC Commercial Unit Mount

1. Measure HVAC Unit (condensing coil side [PKG] or Roof [Comm. Split]) and cut frame to size.
2. Assemble frame components together without solar box.
 1. See Exploded views for hardware. Keep only hand tight to allow adjustment.
 2. For Package Units, mount Top Cross Brace above any angle bracket. This will keep the solar box from rising above the roof.
 3. Mount Bottom Cross Brace well below the Horizontal Support.
 4. Note: Larger (15-Ton) frames have an additional Cross Brace.
 5. Note: Larger (15-Ton) frames have an additional Horizontal Support.
 6. Note: Multiple Solar Boxes can mount to the same Cross Braces, but will need additional Vertical and Horizontal supports as well as additional mounting hardware.
3. See next pages for HVAC Unit mounting.

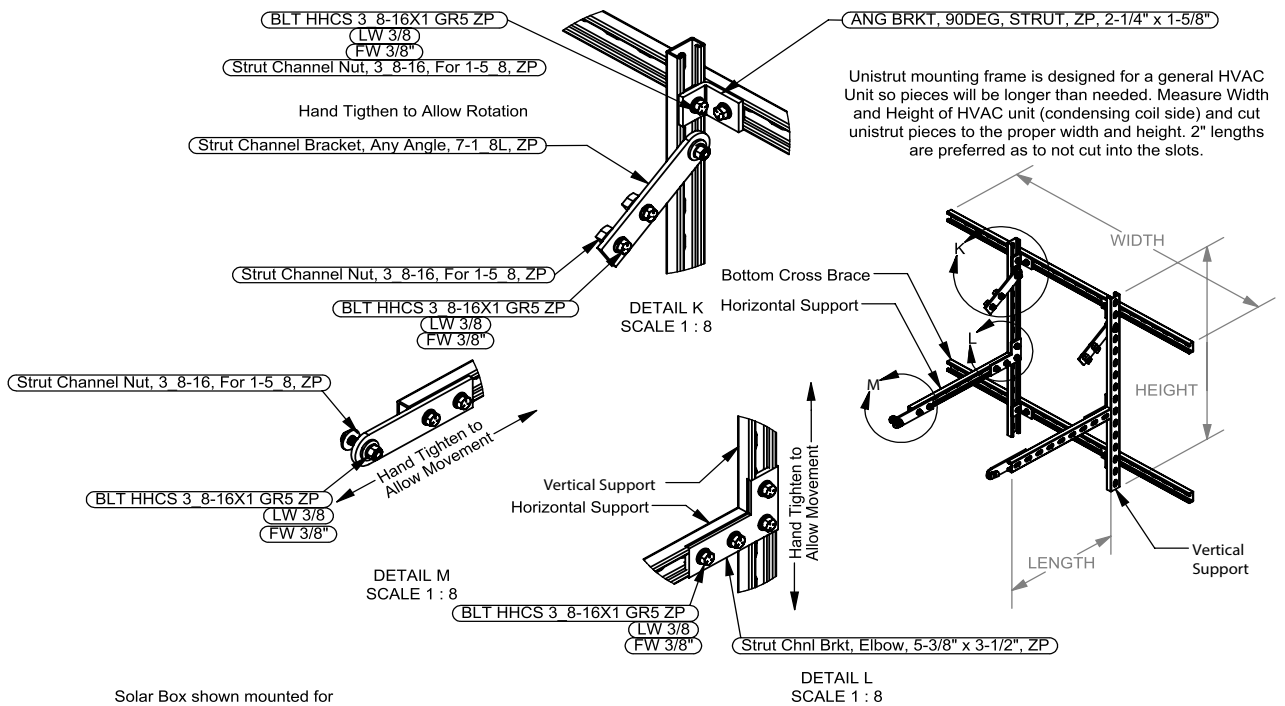

Unistrut mounting frame is designed for a general HVAC Unit so pieces will be longer than needed. Measure Width and Height of HVAC unit (condensing coil side) and cut unistrut pieces to the proper width and height. 2" lengths are preferred as to not cut into the slots.

Solar Box shown mounted for reference only. Mount frame to HVAC Unit prior to mounting solar box.

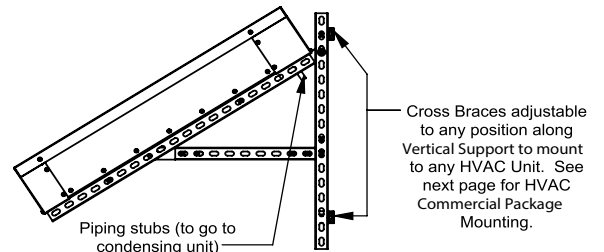
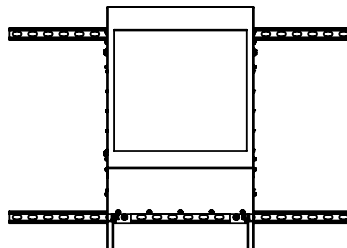
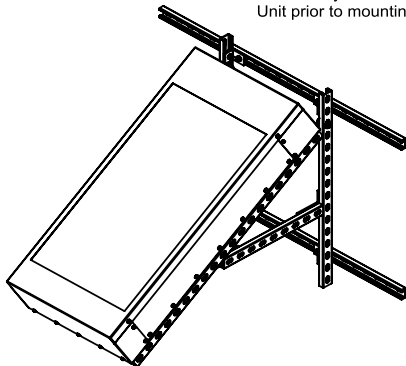

General Assembly Instructions - Commercial Package

Generic Assembly Instructions

HVAC Commercial Package Mount

1. After cutting frame to size and hand tightening general assembly (see previous page). Place frame on condensing coil side of HVAC Unit.
2. Secure bottom width support to base rail and top width support to HVAC Unit frame. **DO NOT DRILL INTO COIL!**
3. Adjust frame shape to desired position.
4. Measure desired angle for Solar Box and fix Horizontal Supports in approximate position. This can be adjusted after Solar Box mounting to ensure desired angle. Follow recommended positioning shown below.
5. Mount Solar Box (pipe pop-outs on top) with edge of strut channels touching to form a solid triangle. Tighten all framing hardware once desired position is obtained.
6. To keep HVAC Unit frame from warping, cut UNV-0161 to length and mount on side of HVAC Unit.
7. Brace and secure piping to unistrut to plumb into the condensing unit. Be sure to follow line length requirements for determining how far away the Solar Box can be mounted.
 1. Shortest length needed to compressor is desired for best results.
 2. Drill 7/8" holes in HVAC Unit paneling and use 5/8" grommets to enter piping into HVAC Unit. If solar boxes are plumbed parallel into a larger pipe, use larger grommets sized accordingly.
8. Plumb pressure suction sensor in suction line before compressor per plumbing schematic.
9. Insulate any exposed copper piping on the outside of HVAC Unit.
10. Mount VFD with bracket into the fan chamber.
 1. Heat Sink must be able to disipate heat.
 2. Set VFD Parameters per unit size. See SCH-0043-E.
11. Mount Solar HVAC Controller in with HVAC Unit Control Panels.
12. Make sure suction pressure sensor is set on Solar HVAC Controller to appropriate pressure.

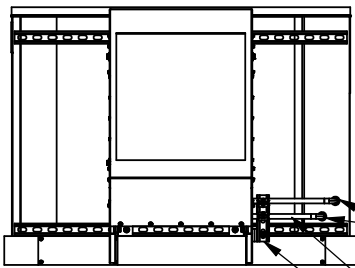

GMT RBBR 5/8" ID FOR 7/8" 1/16" PNL

Insulate any exposed copper piping.

Secure longer runs of piping with scrap unistrut channel and additional brackets (not provided) to prevent wobbling and damage.

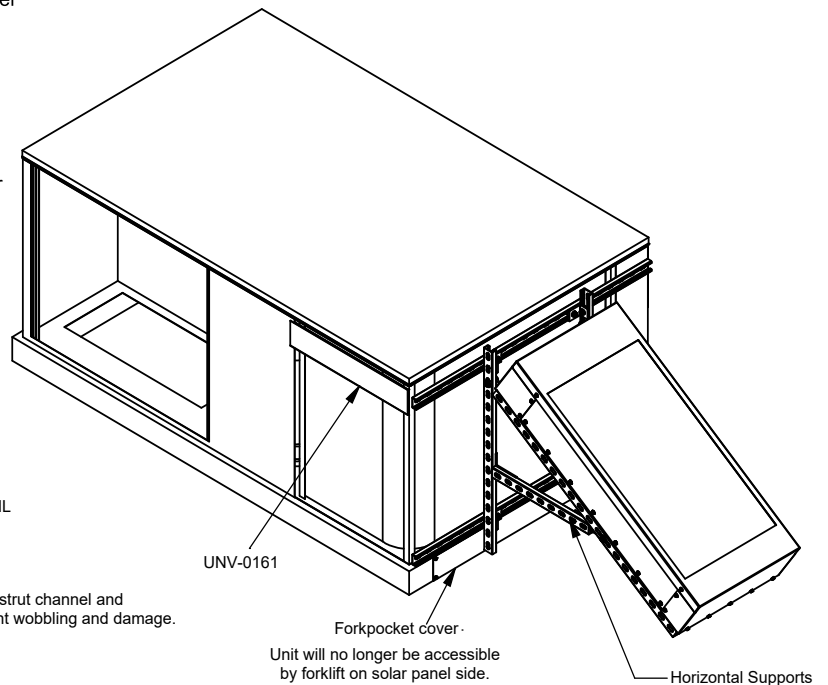

Position Solar Box so top corner is below the roof of the RTU.

If possible, mount Solar Box at a 45 Degree angle. (Between ~30Deg to ~60Deg recommended)

Position Solar Box so bottom corner is above the base rail of the RTU.

Run piping to compressor.

VFD Mounted in Fan Chamber

General Assembly Instructions - Commercial Package

Generic Assembly Instructions

HVAC Commercial Package Mount

1. If the Compressor Access Panel is on the end where the solar box mount, the Solar Boxes can be spread apart and over hang the unit slightly.
2. Mount Solar Boxes spaced out enough to access the panel mounting hardware and to easily remove the panel.
3. Do not plumb, place hardware, or unistut in the way of removing the panel.
4. Total Width of Solar Mount is suggested to not be over 100" maximum. This ensure it will be able to be shipped with standard frieght trucks (102" maximum.)

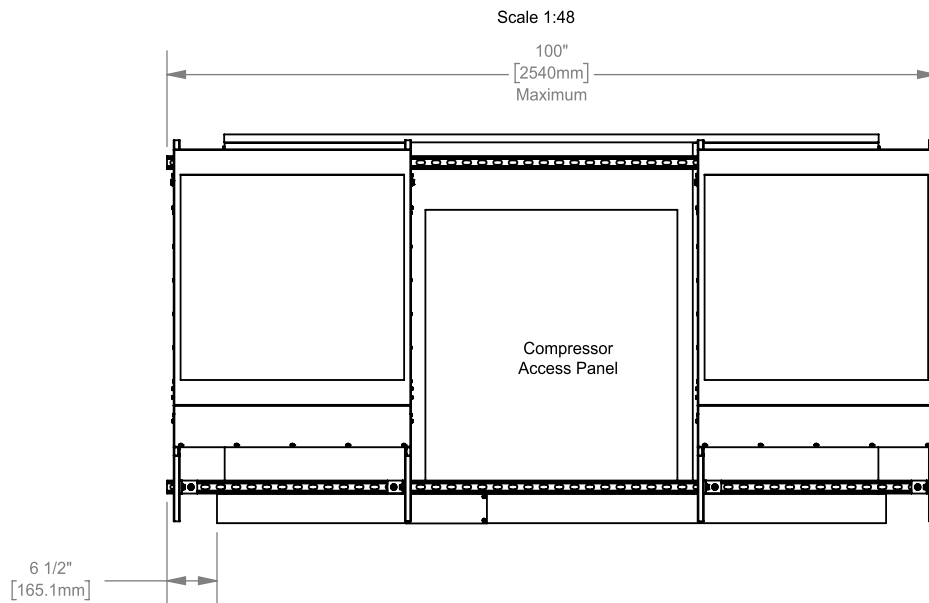
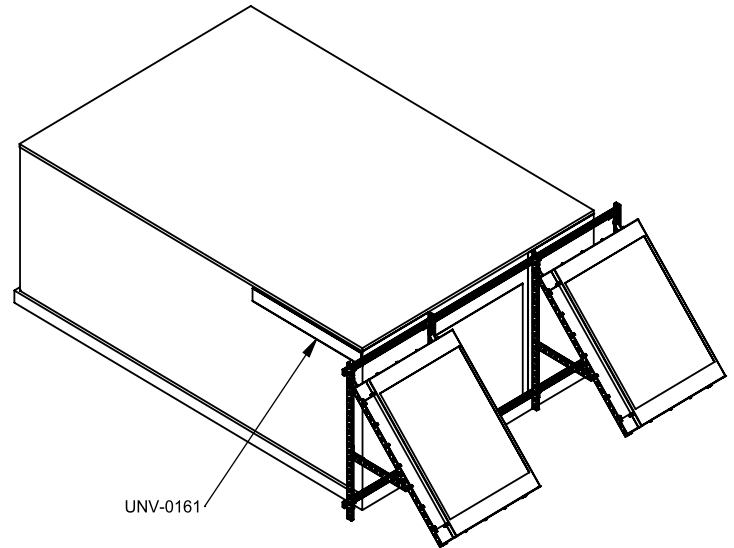

General Assembly Instructions - Commercial Split Mount

Generic Assembly Instructions

HVAC Commercial Split Mount

1. After cutting frame to size and hand tightening general assembly (see previous page). Place frame on the roof of the HVAC Unit.
2. Secure bottom struts to the HVAC Unit roof. Do NOT DRILL INTO THE COIL and avoid fan grating.
3. Adjust frame shape to desired position.
4. Measure desired angle for Solar Box and fix Vertical Supports in approximate position. This can be adjusted after Solar Box mounting to ensure desired angle. Follow recommended positioning shown below.
5. Mount Solar Box (pipe pop-outs on bottom) with edge of strut channels touching to form a solid triangle. Tighten all framing hardware once desired position is obtained.
6. To keep HVAC Unit frame from warping, cut UNV-0161 to length and mount on side of HVAC Unit.
7. Brace and secure piping to unistrut to plumb into the condensing unit. Be sure to follow line length requirements for determining how far away the Solar Box can be mounted.
 1. Shortest length needed to compressor is desired for best results.
 2. Drill 7/8" holes in HVAC Unit paneling and use 5/8" grommets to enter piping into HVAC Unit. If solar boxes are plumbed parallel into a larger pipe, use larger grommets sized accordingly.
8. Plumb pressure suction sensor in suction line before compressor per plumbing schematic.
9. Insulate any exposed copper piping on the outside of HVAC Unit.
10. Mount VFD with bracket into the fan chamber.
 1. Heat Sink must be able to disapate heat.
 2. Set VFD Parameters per unit size. See SCH-0043-E.
11. Mount Solar HVAC Controller in with HVAC Unit Control Panels.
12. Make Sure suction pressure sensor is set on Solar HVAC Controller to appropriate pressure.

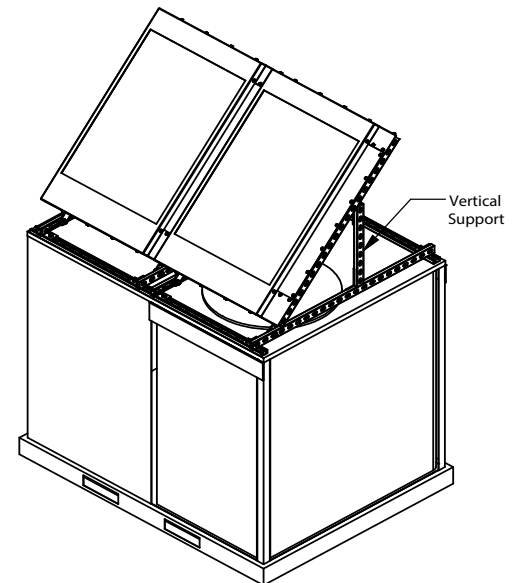
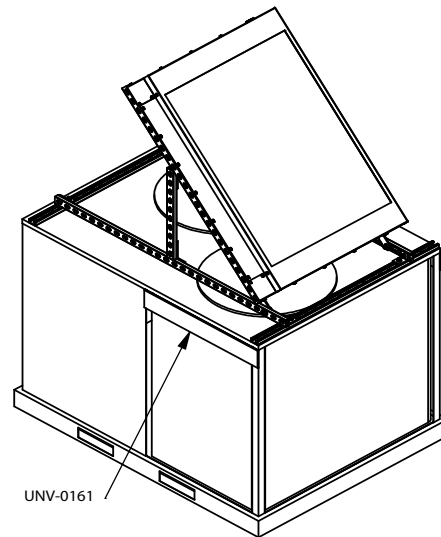

Single Circuit; Single Solar Box Only

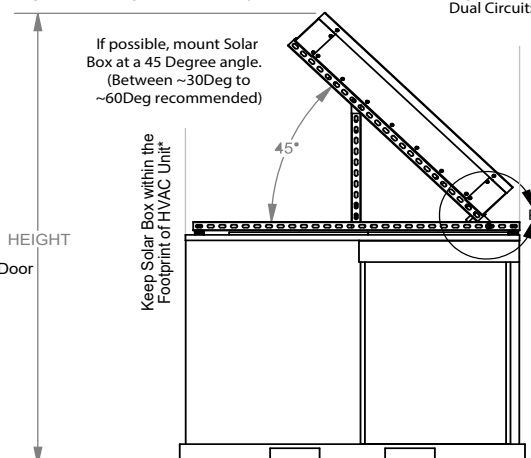

Single Circuit: Plumb Solar Boxes together in Parallel
Dual Circuit: Plumb Solar Boxes one to each Circuit

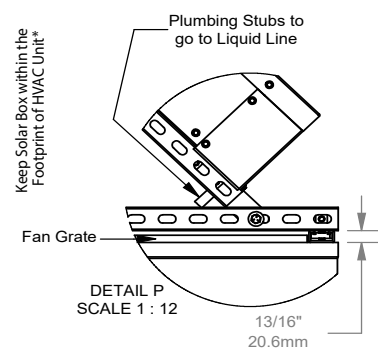

Note Due to HVAC Unit Size and Solar Box selection, there are exceptions to staying within the footprint.

Solar-HVAC-(Liquid)-HeatPump-Piping - SCH-0005-P

PLUMB PER CURCUIT

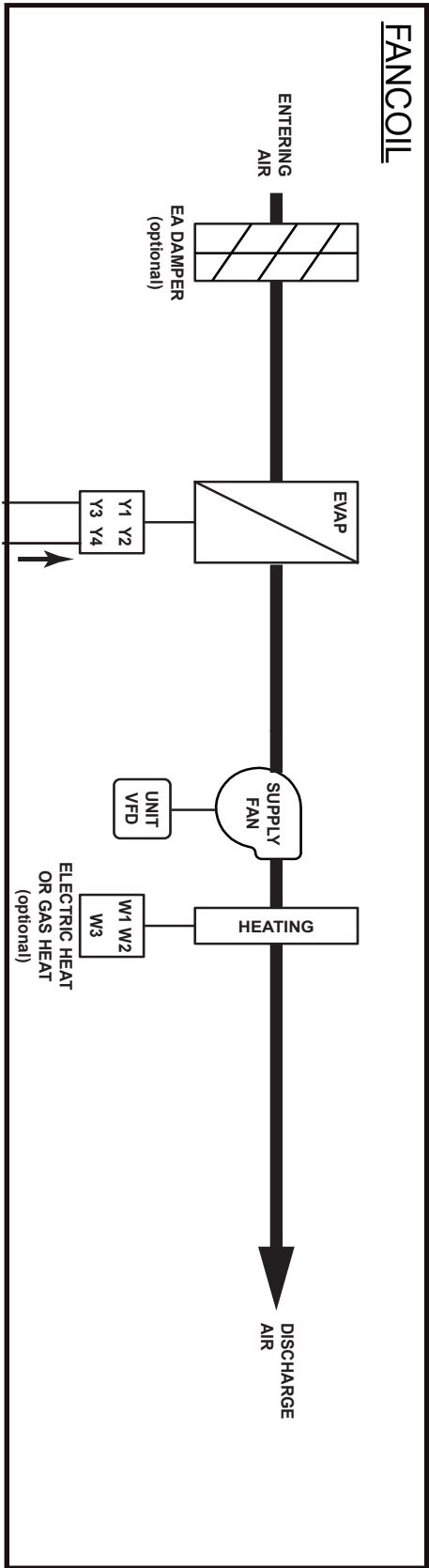

FIELD SUPPLIED PLUMBING ON SPLIT SYSTEMS ONLY

REFGT FLOW DIRECTION FOR HEAT OPERATION

REFGT FLOW DIRECTION FOR COOLING OPERATION

CONDENSING UNIT

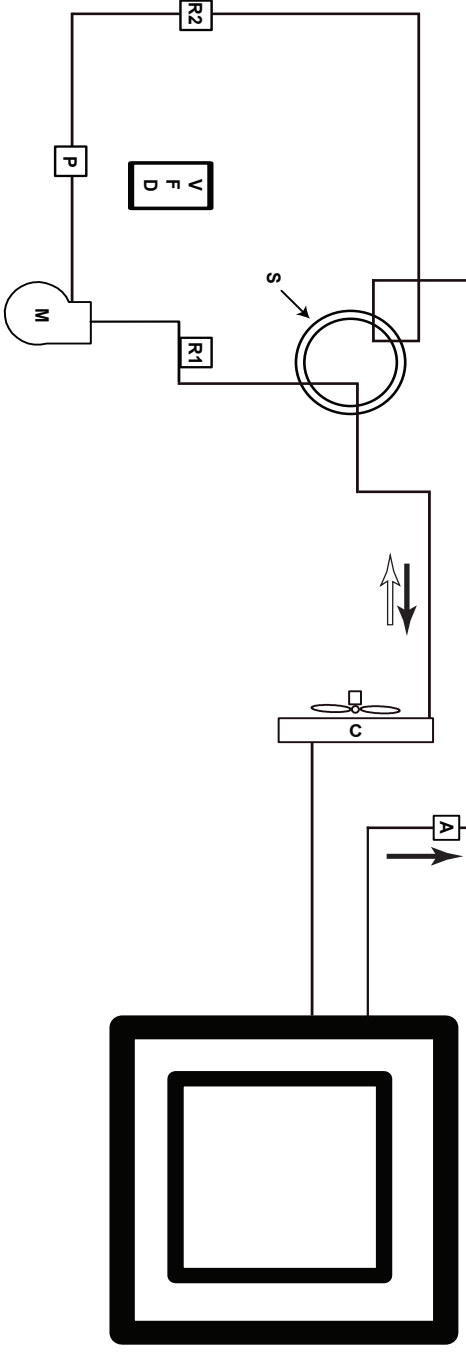

- A - FILTER DRIER
- C - CONDENSER COIL
- M - COMPRESSOR
- P - PRESSURE TRANSDUCER
- R1 - FACTORY HIGH PRESSURE SWITCH (Cooling)
- R2 - FACTORY HIGH PRESSURE SWITCH (Heat)
- S - REVERSING VALVE
- T - FACTORY MAINTENANCE VALVE
- V - VALVE

Solar HVAC (Liquid)-Sng Cir-2xComp-HP Plumbing Diagram - SCH-0029-P

PLUMB PER CURCUIT

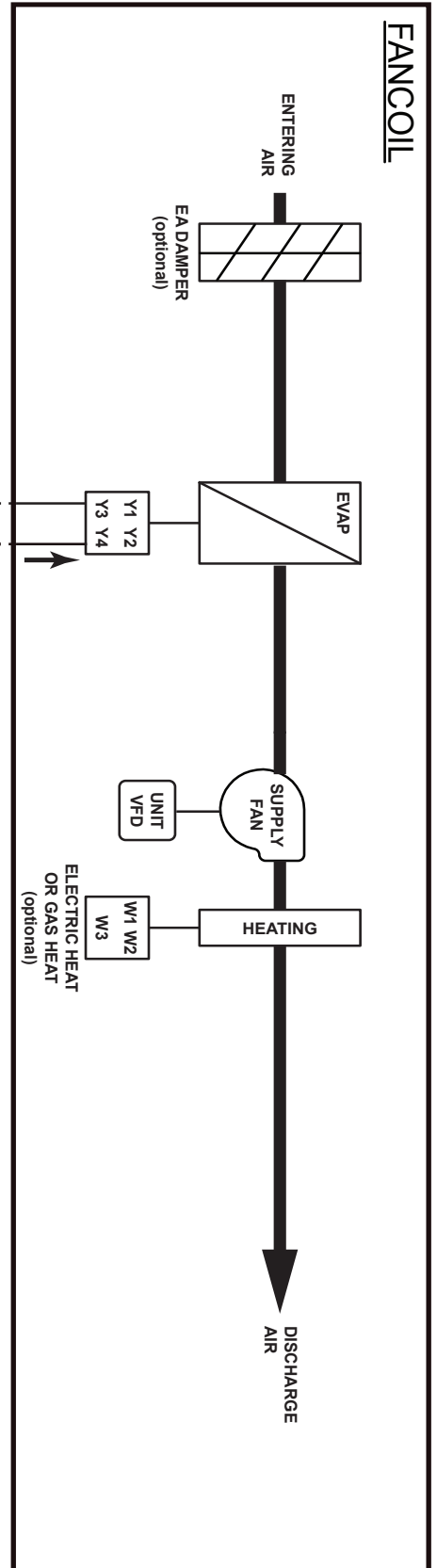

--- FIELD SUPPLIED PLUMBING ON SPLIT SYSTEMS ONLY

↑↑ REFGT FLOW DIRECTION FOR HEAT OPERATION

↑ REFGT FLOW DIRECTION FOR COOLING OPERATION

CONDENSING UNIT

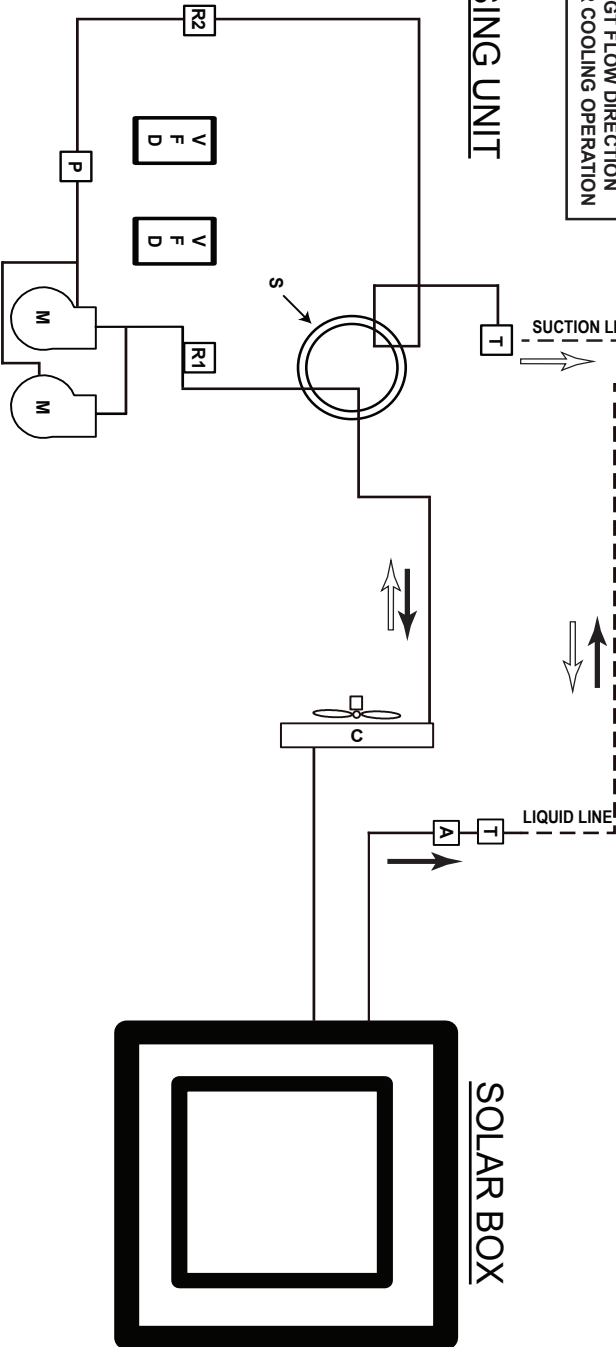

- A - FILTER DRIER
- C - CONDENSER COIL
- M - COMPRESSOR
- P - PRESSURE TRANSDUCER
- R1 - FACTORY HIGH PRESSURE SWITCH (Cooling)
- R2 - FACTORY HIGH PRESSURE SWITCH (Heat)
- S - REVERSING VALVE
- T - FACTORY MAINTENANCE VALVE
- V - VALVE

Solar HVAC (Liquid)-Sng Cir-2xComp-DX Cool _Gas Plumbing Diagram - SCH-0028-P

PLUMB PER CURCUIT

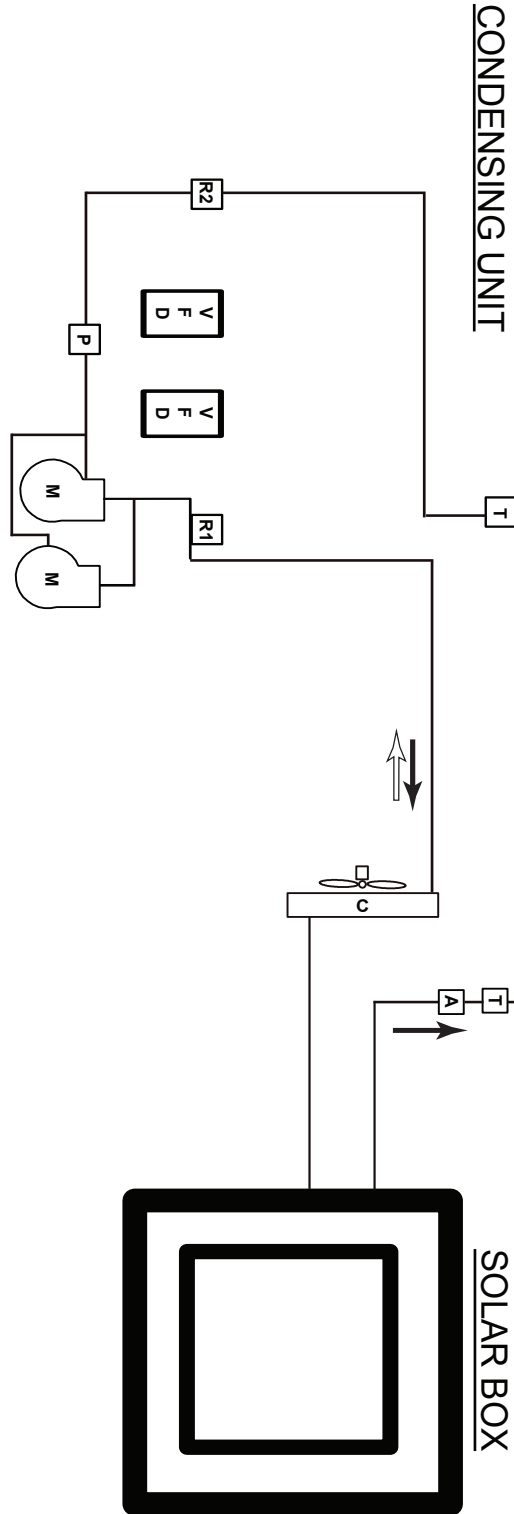
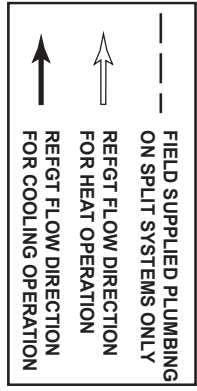
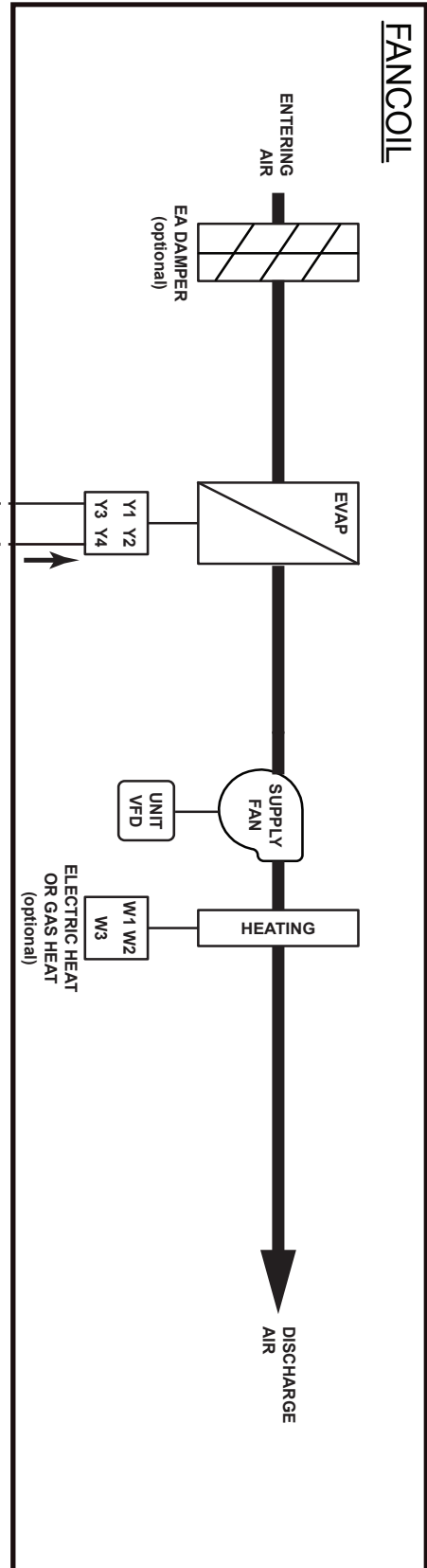

- A - FILTER DRIER
- C - CONDENSER COIL
- M - COMPRESSOR
- P - PRESSURE TRANSDUCER

- R1 - FACTORY HIGH PRESSURE SWITCH (Cooling)
- R2 - FACTORY HIGH PRESSURE SWITCH (Heat)
- T - FACTORY MAINTENANCE VALVE
- V - VALVE

Solar HVAC (Liquid) Cooling-Gas Heat - SCH-0006-P

PLUMB PER CURCUIT

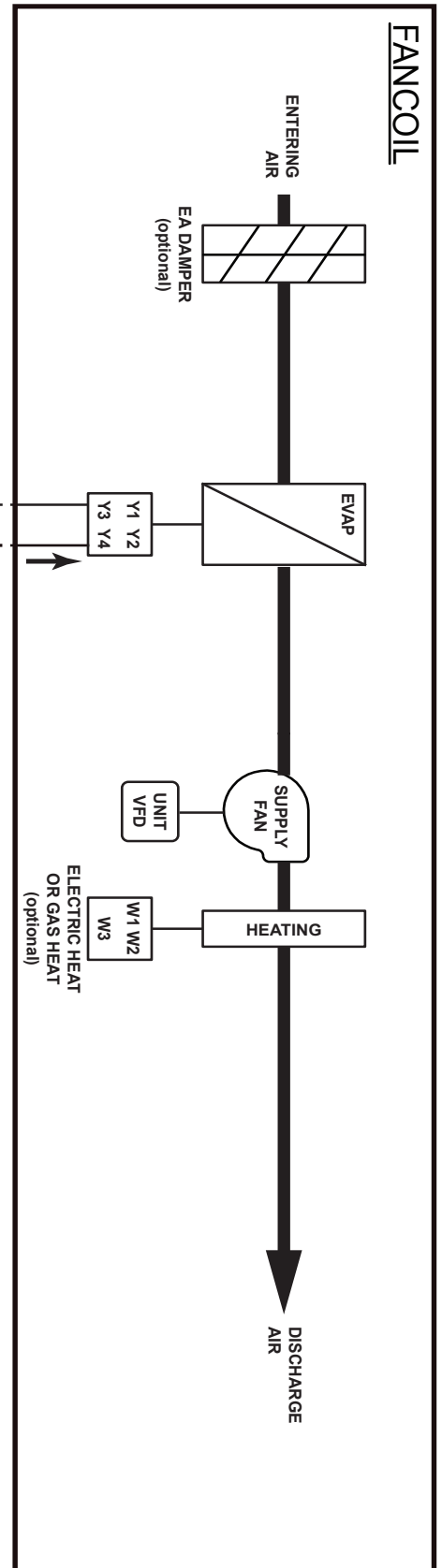

--- FIELD SUPPLIED PLUMBING
ON SPLIT SYSTEMS ONLY

↑ REFGT FLOW DIRECTION FOR COOLING OPERATION

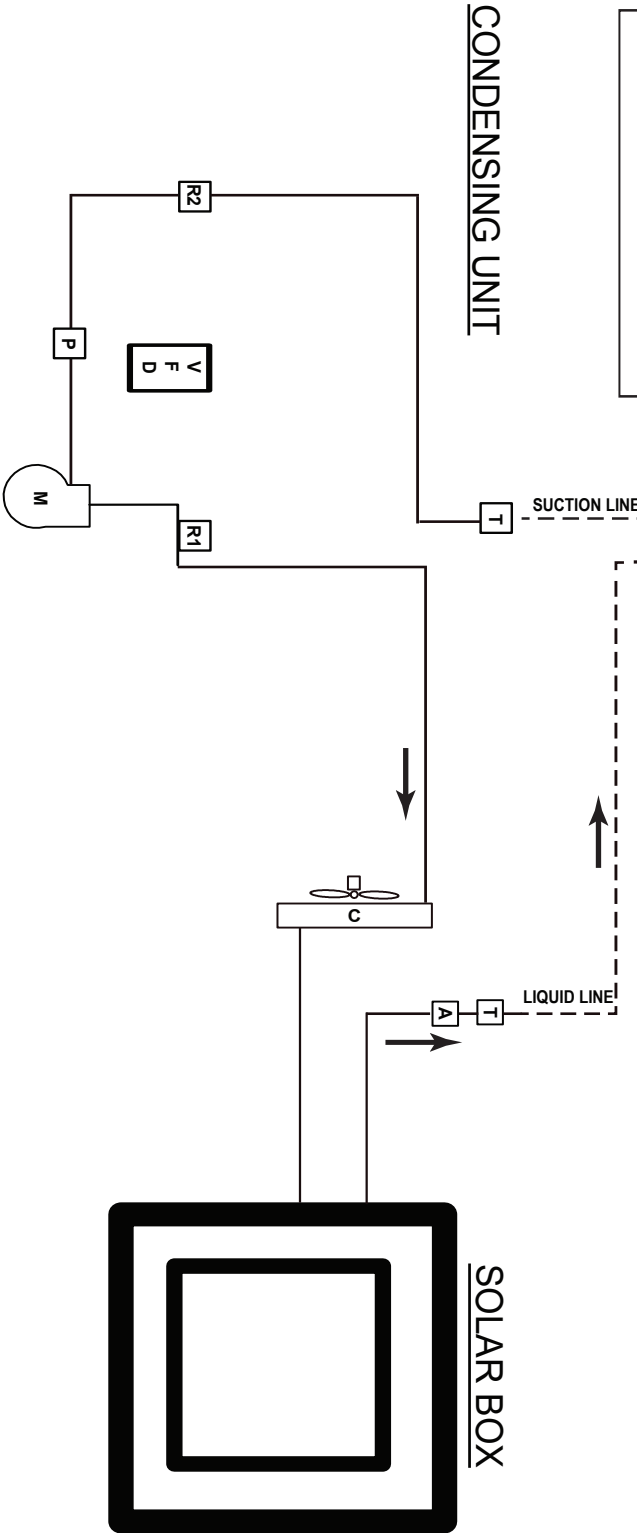

- A - FILTER DRIER
- C - CONDENSER COIL
- M - COMPRESSOR
- P - PRESSURE TRANSDUCER

- R1 - FACTORY HIGH PRESSURE SWITCH (Cooling)
- R2 - FACTORY HIGH PRESSURE SWITCH (Heat)
- T - FACTORY MAINTENANCE VALVE
- V - VALVE

Solar HVAC (Liquid) - 2xSolar Box [Parallel] - Cooling or Gas Plumbing Diagram - SCH-0031-P

PLUMB PER CURRCUIT

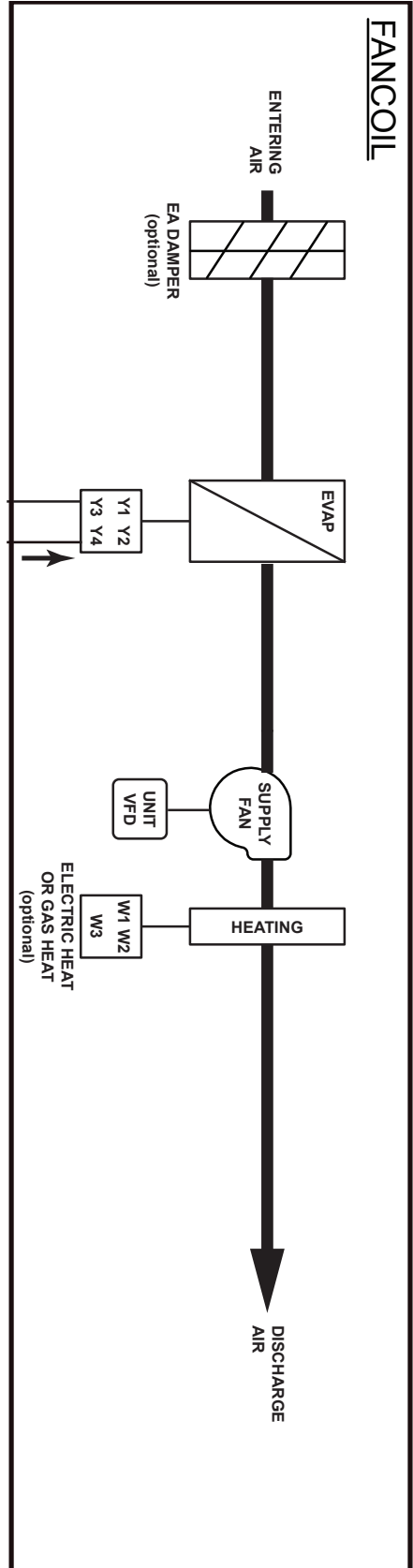

FIELD SUPPLIED PLUMBING
ON SPLIT SYSTEMS ONLY
REFGT FLOW DIRECTION
FOR COOLING OPERATION

CONDENSING UNIT

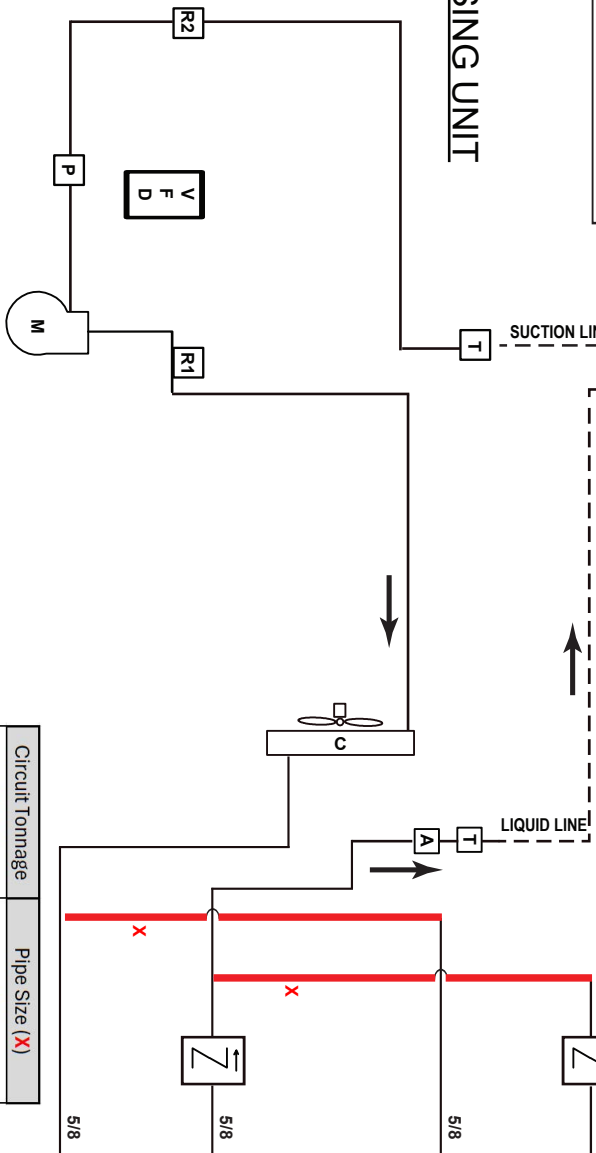

- A - FILTER DRIER
- C - CONDENSER COIL
- M - COMPRESSOR
- P - PRESSURE TRANSDUCER
- R1 - FACTORY HIGH PRESSURE SWITCH (Cooling)
- R2 - FACTORY HIGH PRESSURE SWITCH (Heat) T - FACTORY MAINTENANCE VALVE
- V - VALVE

Circuit Tonnage	Pipe Size (X)
10-Ton	5/8
15-Ton	5/8
20-Ton	7/8
25-Ton	7/8
30-Ton	1-1/8

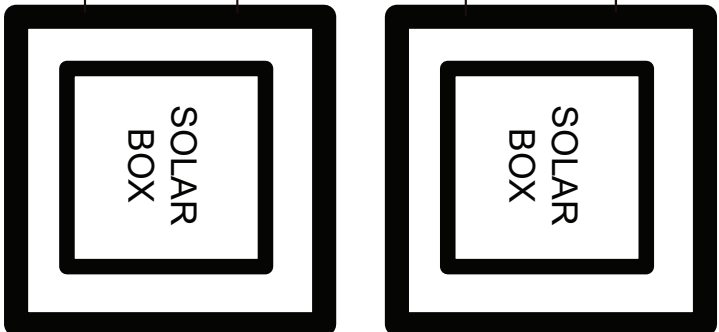

X Note: Reference circuit tonnage chart for combined pipe size.

Solar HVAC (Liquid) - 2xSolar Box [Parallel] - Single Circuit - Dual Compressor - Cooling or Gas Plumbing Diagram - SCH-0033-P

PLUMB PER CURRCUIT

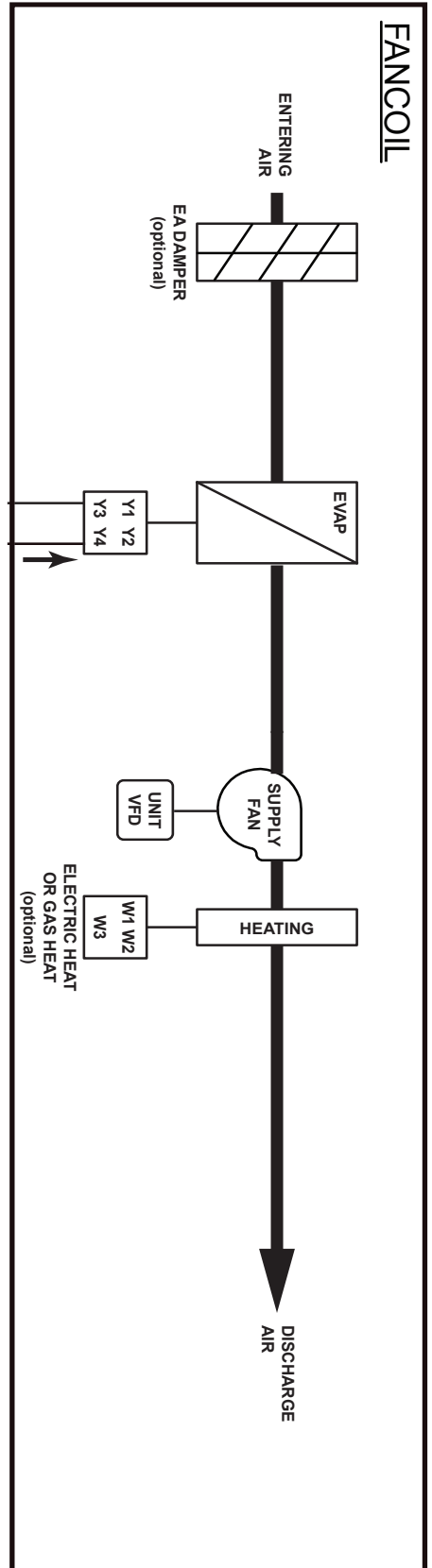

FIELD SUPPLIED PLUMBING ON SPLIT SYSTEMS ONLY
 REFRT FLOW DIRECTION FOR COOLING OPERATION

CONDENSING UNIT

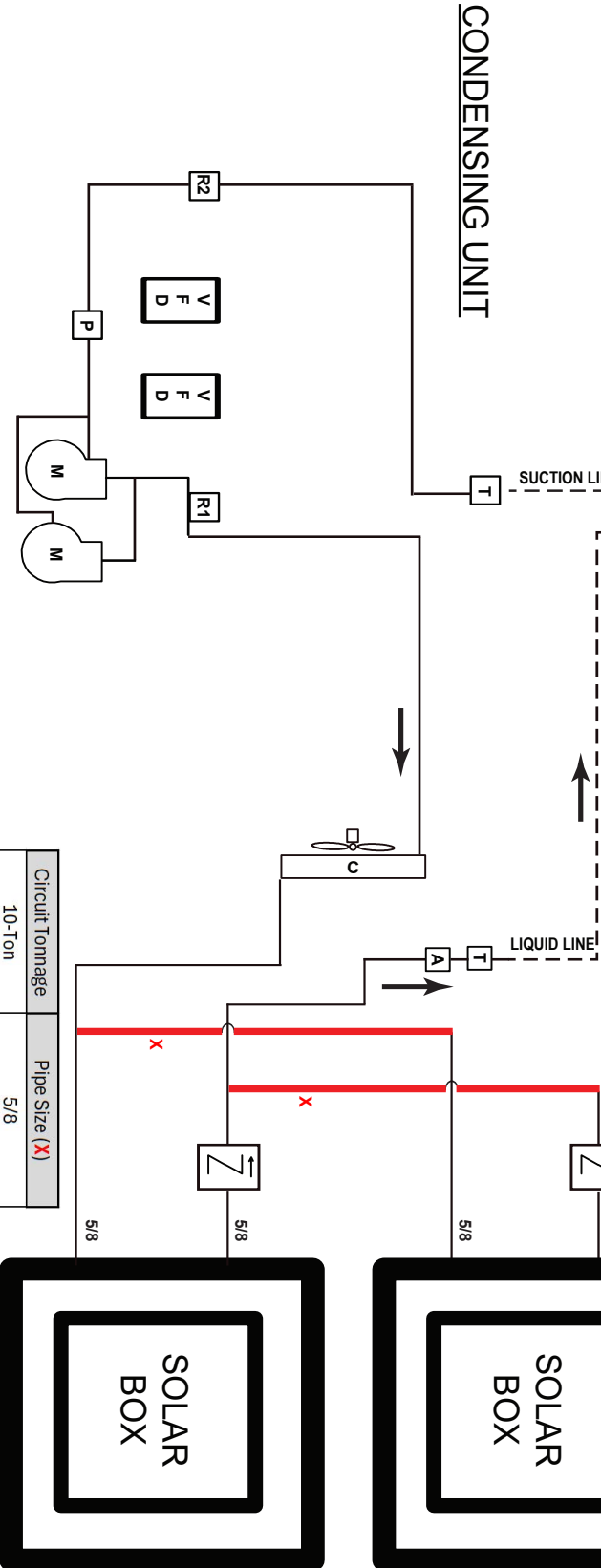

- A - FILTER DRIER
- C - CONDENSER COIL
- M - COMPRESSOR
- P - PRESSURE TRANSDUCER

- R1 - FACTORY HIGH PRESSURE SWITCH (Cooling)
- R2 - FACTORY HIGH PRESSURE SWITCH (Heat)
- T - FACTORY MAINTENANCE VALVE
- V - VALVE

Circuit Tonnage	Pipe Size (X)
10-Ton	5/8
15-Ton	5/8
20-Ton	7/8
25-Ton	7/8
30-Ton	1-1/8

X Note: Reference circuit tonnage chart for combined pipe size.

Solar Rack Plumbing Diagram - Multiple Variations - SCH-0020-P (Page1)

* Check Part Number and Description to Determine What Solar Boxes Should Be Plumbed Together

B - BALL VALVE

Two Boxes, Dual Circuit

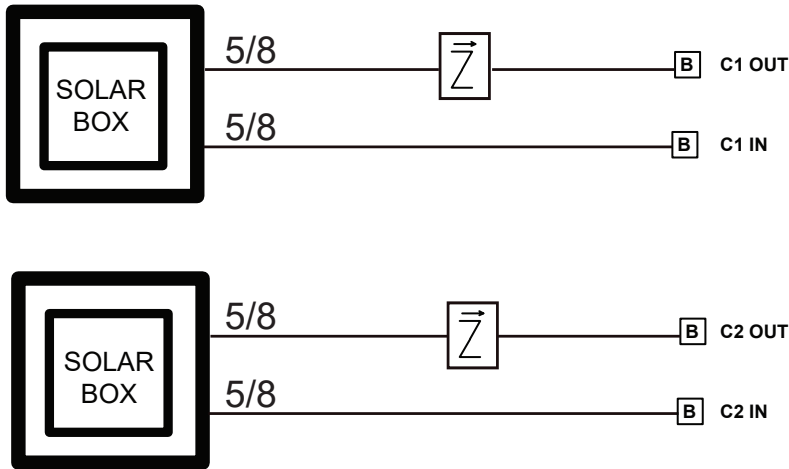

Circuit Tonnage	Valve Size
10-Ton	5/8
15-Ton	5/8
20-Ton	7/8
25-Ton	7/8
30-Ton	1-1/8
35-Ton	1-1/8
40-Ton	1-1/8
45-Ton	1-1/8
50-Ton	1-3/8
55-Ton	1-3/8
60-Ton	1-3/8

Note: This chart assumes multiple box circuits are plumbed in parallel. Pipe diameters were determined for the liquid line and within 15-Feet of HVAC unit. For longer pipe lengths, pipe diameters would have to be reviewed.

Three Boxes, Dual Circuit, Parallel

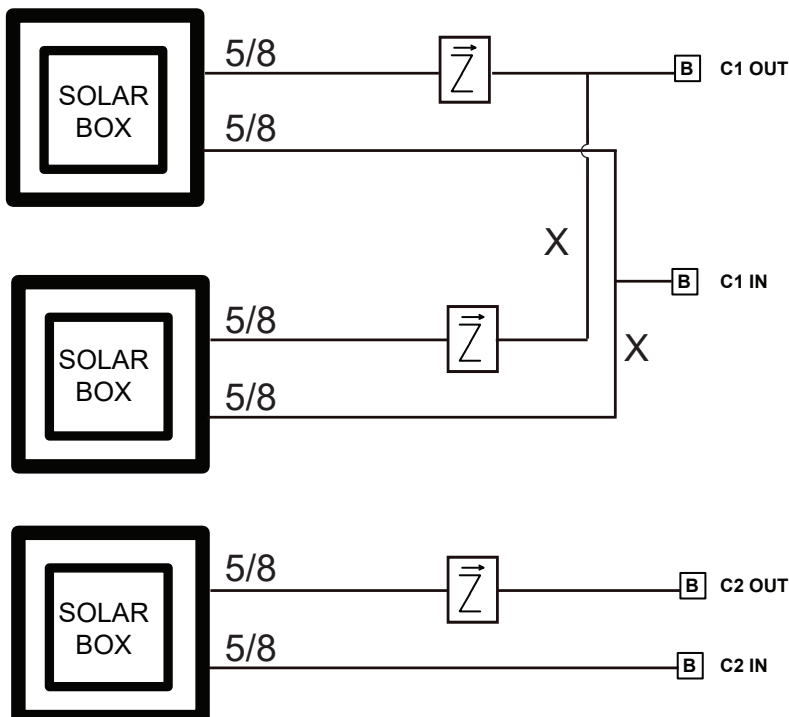

X Note: Reference circuit tonnage chart above for combined pipe and valve size.

Solar Rack Plumbing Diagram - Multiple Variations - SCH-0020-P (Page2)

* Check Part Number and Description to Determine What Solar Boxes Should Be Plumbed Together

B - BALL VALVE

Four Boxes, 3x1 Dual Circuit, Parallel

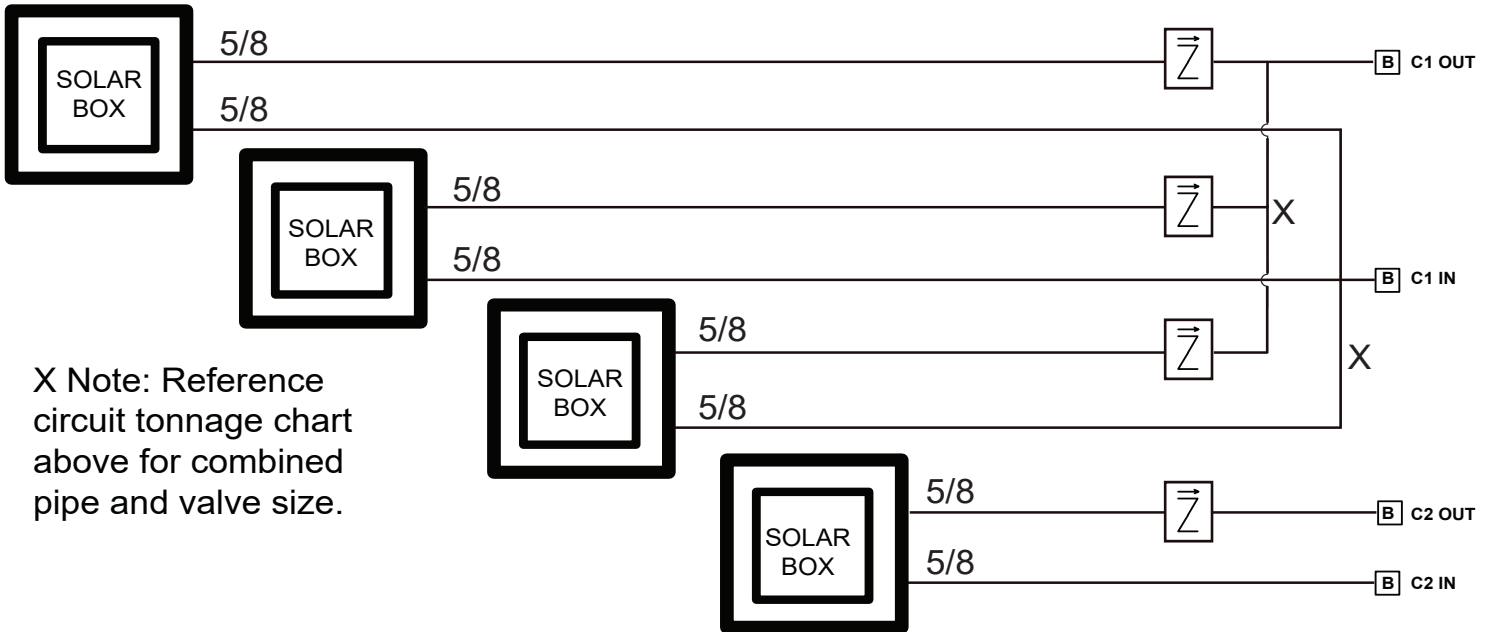

X Note: Reference circuit tonnage chart above for combined pipe and valve size.

Four Boxes, 2x2 Dual Circuit, Parallel

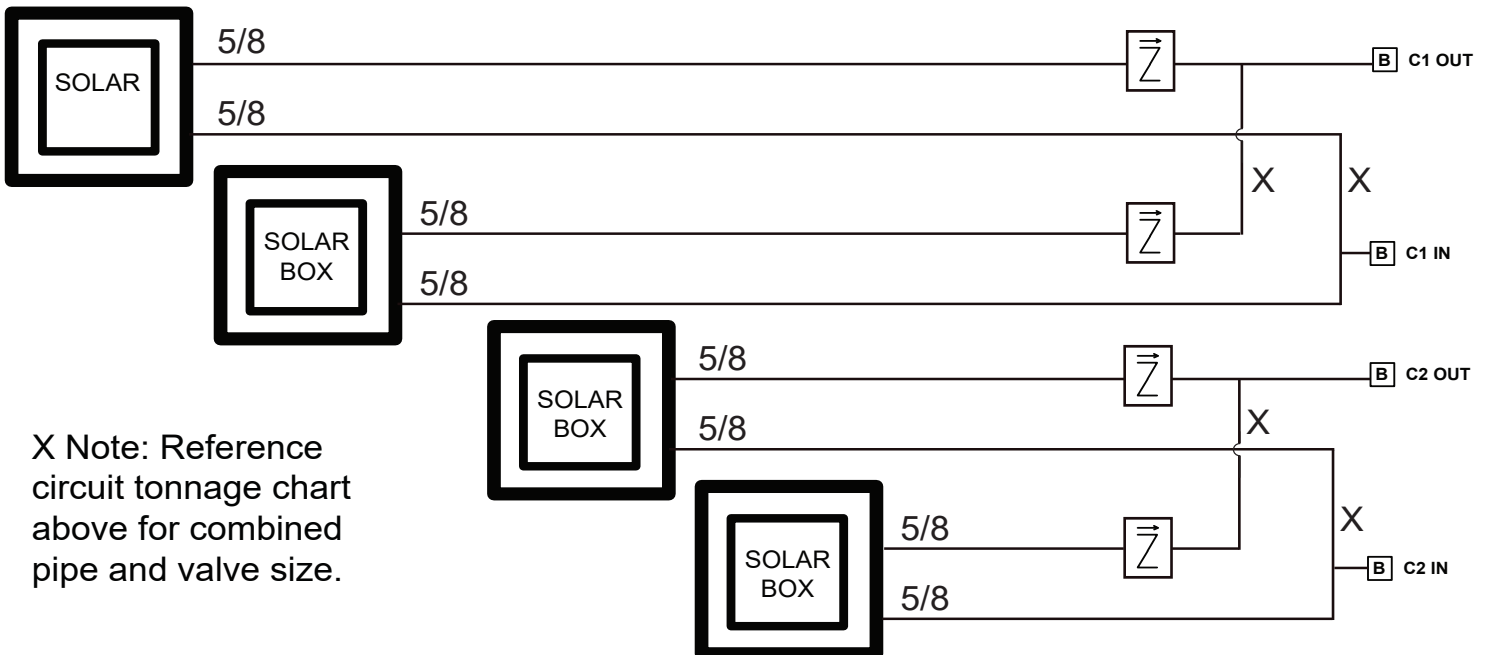

X Note: Reference circuit tonnage chart above for combined pipe and valve size.

Solar Rack Plumbing Diagram - Multiple Variations - SCH-0020-P (Page3)

*** Check Part Number and Description to Determine What Solar Boxes Should Be Plumbed Together**

B - BALL VALVE

Two or More Boxes, Single Circuit, Parallel

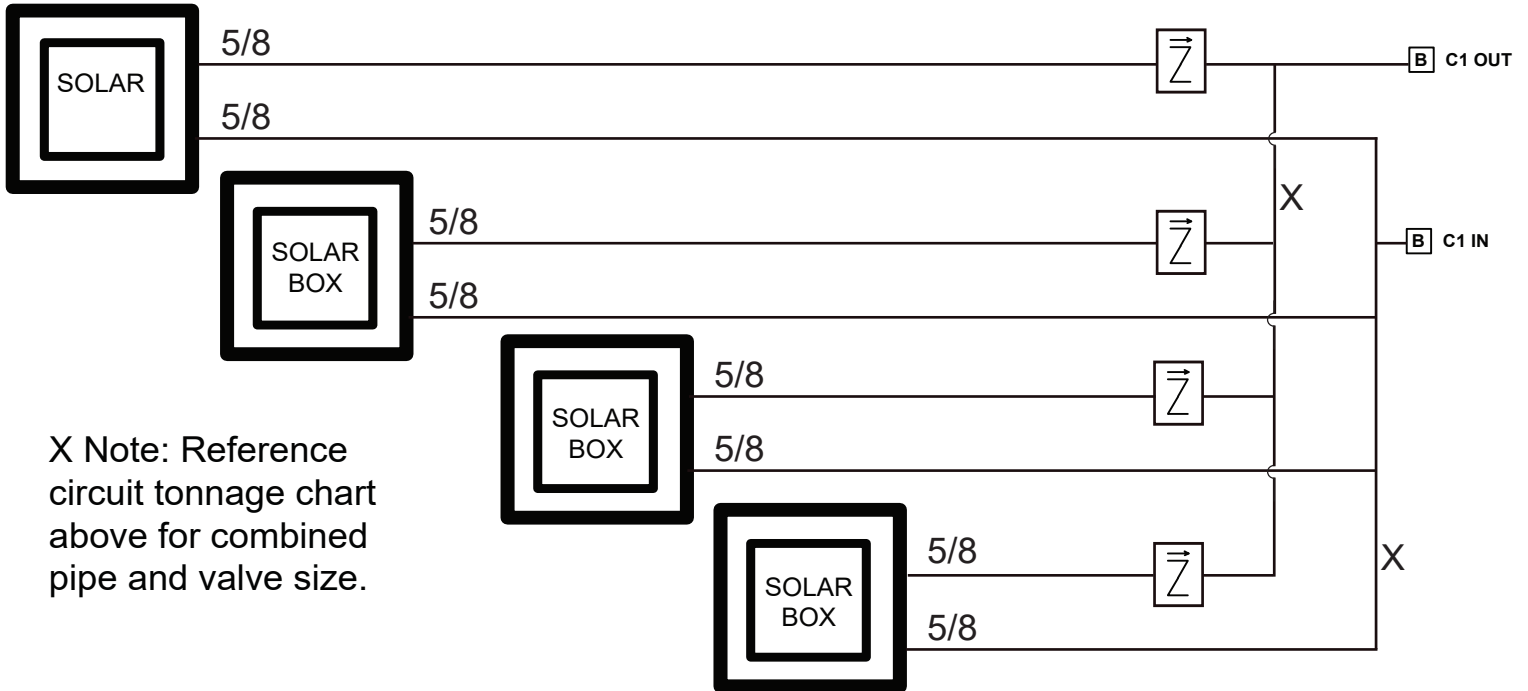

X Note: Reference circuit tonnage chart above for combined pipe and valve size.

ADD SOLAR BOXES IN PARALLEL UNTIL TONNAGE REQUIREMENTS ARE MET

Tstat VFD Comp Wiring Diagram - SCH-0026-E

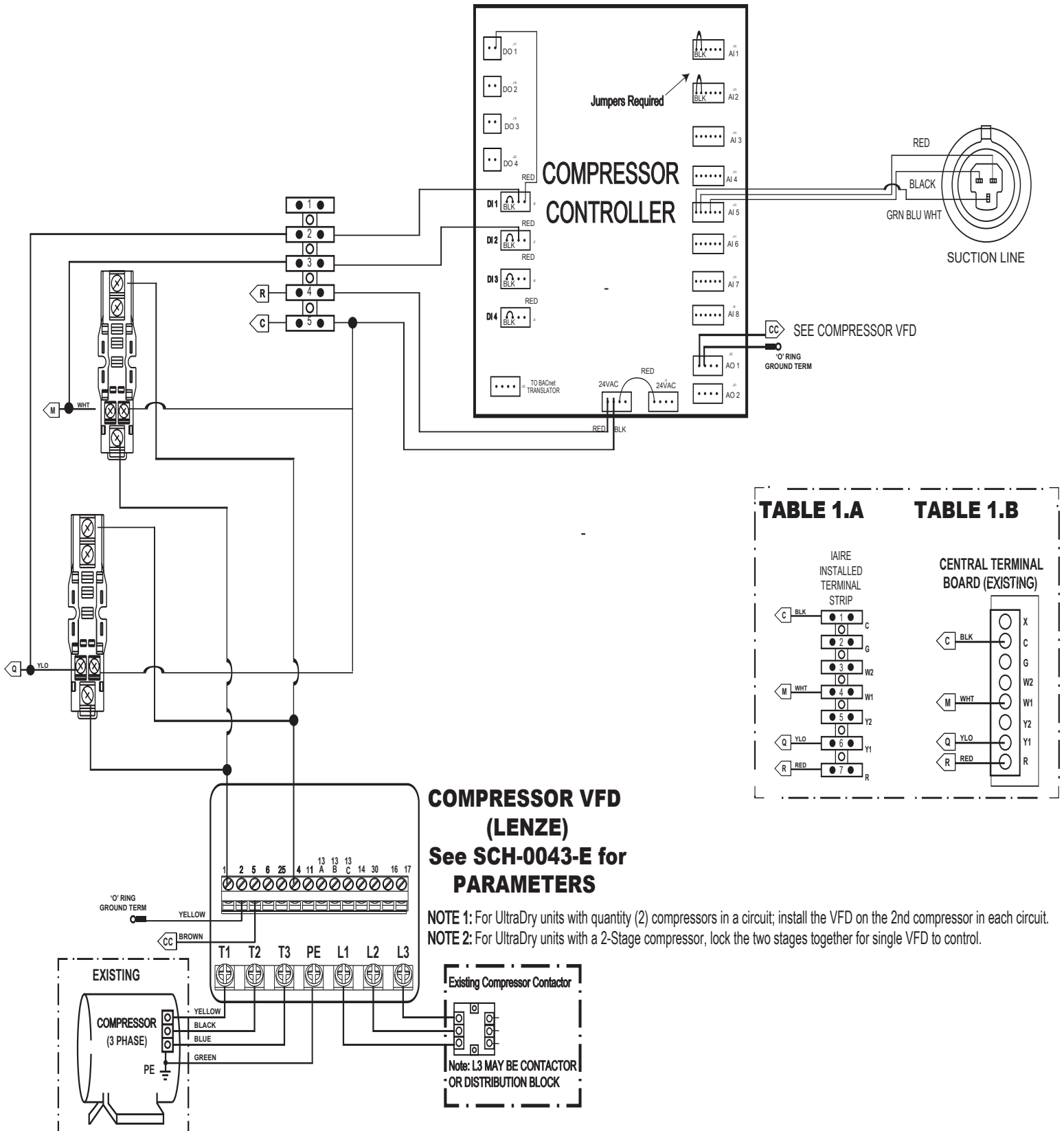
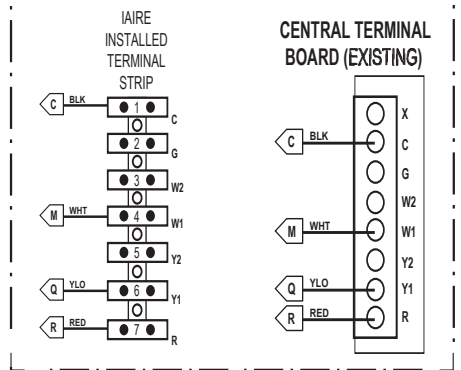

TABLE 1.A

TABLE 1.B



COMPRESSOR VFD (LENZE)
See SCH-0043-E for PARAMETERS

NOTE 1: For UltraDry units with quantity (2) compressors in a circuit; install the VFD on the 2nd compressor in each circuit.
NOTE 2: For UltraDry units with a 2-Stage compressor, lock the two stages together for single VFD to control.

Compressor Driven VFD Parameters - SCH-0043-E

	Solar HVAC											
			Comp 1		Comp 2				Comp 1		Comp 2	
	P100	P101	P102	P103	P102	P103	P110	P140	P160	P161	P160	P161
FC04 - 1ph	1	1	25	60	N/A	N/A	6	5	0	60	N/A	N/A
FC05 - 1ph	1	1	25	52	N/A	N/A	6	5	0	52	N/A	N/A
FC06 - 1ph	1	1	25	55	N/A	N/A	6	5	0	55	N/A	N/A
FC04	1	1	25	60	N/A	N/A	6	5	0	60	N/A	N/A
FC05	1	1	25	60	N/A	N/A	6	5	0	60	N/A	N/A
FC06	1	1	25	60	N/A	N/A	6	5	0	60	N/A	N/A
FC07	1	1	25	60	N/A	N/A	6	5	0	60	N/A	N/A
FC08	1	1	45	60	25	60	6	5	0	60	25	60
FC09	1	1	45	60	25	60	6	5	0	60	25	60
FC12	1	1	45	60	25	60	6	5	0	60	25	60
FC14	1	1	45	60	25	60	6	5	0	60	25	60
FC16	1	1	45	60	25	60	6	5	0	60	25	60
FC20	1	1	45	60	25	60	6	5	0	60	25	60
FC24	1	1	45	60	25	60	6	5	0	60	25	60
FC28	1	1	45	60	25	60	6	5	0	60	25	60
FC30	1	1	45	60	25	60	6	5	0	60	25	60
FCQ04 - 1ph	1	1	25	60	N/A	N/A	6	5	0	60	N/A	N/A
FCQ05 - 1 ph	1	1	25	52	N/A	N/A	6	5	0	52	N/A	N/A
FCQ06 - 1 ph	1	1	25	55	N/A	N/A	6	5	0	55	N/A	N/A
FCQ04	1	1	25	60	N/A	N/A	6	5	0	60	N/A	N/A
FCQ05	1	1	25	60	N/A	N/A	6	5	0	60	N/A	N/A
FCQ06	1	1	25	60	N/A	N/A	6	5	0	60	N/A	N/A
FCQ07	1	1	25	60	N/A	N/A	6	5	0	60	N/A	N/A
FCQ08	1	1	45	60	25	60	6	5	0	60	25	60
FCQ09	1	1	45	60	25	60	6	5	0	60	25	60
FCQ12	1	1	45	60	25	60	6	5	0	60	25	60
FCQ14	1	1	45	60	25	60	6	5	0	60	25	60
FCQ17	1	1	45	60	25	60	6	5	0	60	25	60
FCQ24	1	1	45	60	25	60	6	5	0	60	25	60
FCQ28	1	1	45	60	25	60	6	5	0	60	25	60
GC04-1 ph	1	1	25	60	N/A	N/A	6	5	0	60	N/A	N/A
GC05-1 ph	1	1	25	52	N/A	N/A	6	5	0	52	N/A	N/A
GC06-1 ph	1	1	25	55	N/A	N/A	6	5	0	55	N/A	N/A
GC04	1	1	25	60	N/A	N/A	6	5	0	60	N/A	N/A
GC05	1	1	25	60	N/A	N/A	6	5	0	60	N/A	N/A
GC06	1	1	25	60	N/A	N/A	6	5	0	60	N/A	N/A
GC07	1	1	45	60	25	60	6	5	0	60	25	60
GC08	1	1	45	60	25	60	6	5	0	60	25	60
GC09	1	1	45	60	25	60	6	5	0	60	25	60
GC12	1	1	45	60	25	60	6	5	0	60	25	60
GC14	1	1	45	60	25	60	6	5	0	60	25	60
GC17	1	1	45	60	25	60	6	5	0	60	25	60
GC20	1	1	45	60	25	60	6	5	0	60	25	60
GC24	1	1	45	60	25	60	6	5	0	60	25	60
GC27	1	1	45	60	25	60	6	5	0	60	25	60
GCQ04-1 ph	1	1	25	60	N/A	N/A	6	5	0	60	N/A	N/A
GCQ05-1 ph	1	1	25	52	N/A	N/A	6	5	0	52	N/A	N/A
GCQ06-1 ph	1	1	25	55	N/A	N/A	6	5	0	55	N/A	N/A
GCQ04	1	1	25	60	N/A	N/A	6	5	0	60	N/A	N/A
GCQ05	1	1	25	60	N/A	N/A	6	5	0	60	N/A	N/A
GCQ06	1	1	25	60	N/A	N/A	6	5	0	60	N/A	N/A

	Solar HVAC											
			Comp 1		Comp 2				Comp 1		Comp 2	
	P100	P101	P102	P103	P102	P103	P110	P140	P160	P161	P160	P161
AZRF07	1	1	45	60	25	60	6	5	0	60	0	60
AZRF08	1	1	45	60	25	60	6	5	0	60	0	60
AZRF12	1	1	45	60	25	60	6	5	0	60	0	60
AZRF14	1	1	45	60	25	60	6	5	0	60	0	60
AZRF16	1	1	45	60	25	60	6	5	0	60	0	60
AZRF25	1	1	45	60	25	60	6	5	0	60	0	60
AQRF07	1	1	45	60	25	60	6	5	0	60	0	60
AQRF08	1	1	45	60	25	60	6	5	0	60	0	60
AQRF12	1	1	45	60	25	60	6	5	0	60	0	60
AQRF16	1	1	45	60	25	60	6	5	0	60	0	60
AQRF25	1	1	45	60	25	60	6	5	0	60	0	60

NOTE 1:

For iAIRE Heat Pumps FZ** uses the same parameters as FCQ**

Example: FZ08 would use FCQ08

Example: GZ08 would be GCQ08

NOTE 2:

For TC/HC or TCQ/HCQ units use TC=FC and HC=GC

Example: TC14 would use FC14

Example: HC14 would use GC14

Example: TCQ14 would use FCQ14

	Solar HVAC																								
			Comp 1		Comp 2				Comp 1		Comp 2				Comp 3		Comp 4								
	P100	P101	P102	P103	P102	P103	P110	P140	P160	P161	P160	P161	P100	P101	P102	P103	P102	P103	P104	P110	P140	P160	P161	P160	P161
A30	1	1	25	60	25	60	6	5	0	60	0	60	1	1	45	60	25	60	3	6	5	0	60	0	60
A35	1	1	25	60	25	60	6	5	0	60	0	60	1	1	45	60	25	60	3	6	5	0	60	0	60
A40	1	1	25	60	25	60	6	5	0	60	0	60	1	1	45	60	25	60	3	6	5	0	60	0	60
A50	1	1	25	60	25	60	6	5	0	60	0	60	1	1	45	60	25	60	3	6	5	0	60	0	60
A60	1	1	25	60	25	60	6	5	0	60	0	60	1	1	45	60	25	60	3	6	5	0	60	0	60

Maintenance

- Clean glass of solar collector when doing other routine maintenance on the HVAC Unit.

Spare Parts

Description	Item
Solar HVAC Controller	PRG-SH-MAIN V1.~~ KIT
Suction Pressure Sensor	SEN-0055 KIT
3.75-Ton Solar Box	SLR-BX-03C31.50 V2
5-Ton Solar Box	SLR-BX-04C31.50 V2
7.5-Ton Solar Box	SLR-BX-05C37.50 V2
10-Ton Solar Box	SLR-BX-05C50.00 V2
15-Ton Solar Box	SLR-BX-05C75.00 V2

Solar Box Dimensions (1.25 - 5.00 ton)

SLR-BX-02C15.75

1.25 Ton Solar Box

2 Heat Chambers at a Length of 15.75"

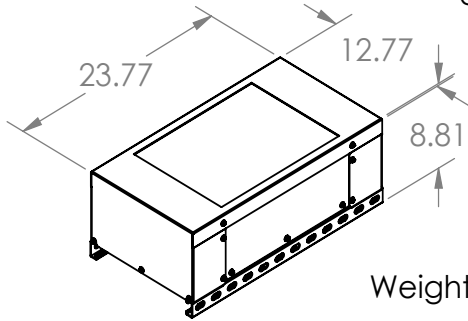

Weight: 25 lbs

SLR-BX-02C31.50

2.50 Ton Solar Box

2 Heat Chambers at a Length of 31.50"

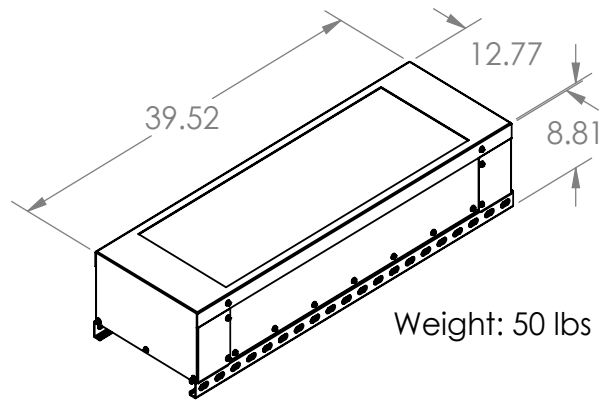

Weight: 50 lbs

SLR-BX-03C31.50 V2

3.75 Ton Solar Box

3 Heat Chambers at a Length of 31.50"
Unistrut Mounting

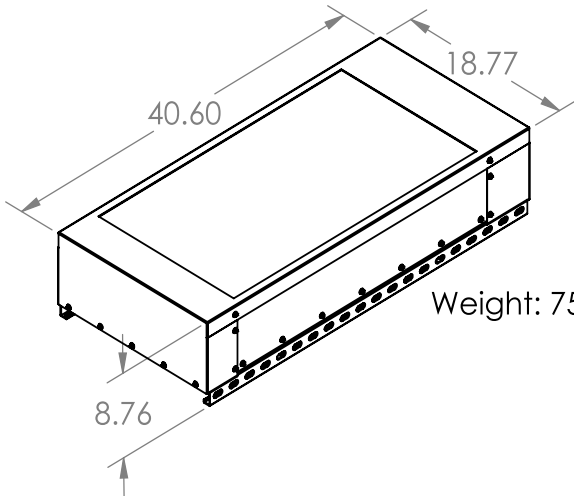

Weight: 75 lbs

SLR-BX-04C31.50 V2

5.00 Ton Solar Box

4 Heat Chambers at a Length of 31.50"
Unistrut Mounting

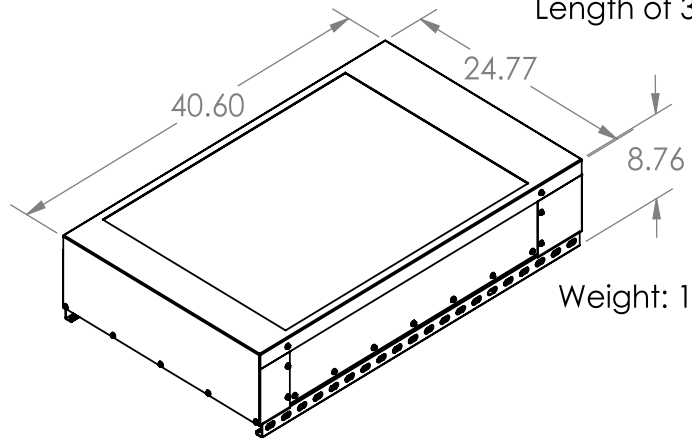

Weight: 100 lbs

Solar Box Dimensions (7.50 - 15.0 ton)

SLR-BX-05C37.50 V2

7.50 Ton
Solar Box

5 Heat Chambers
at a
Length of 37.50"
Unistrut Mounting

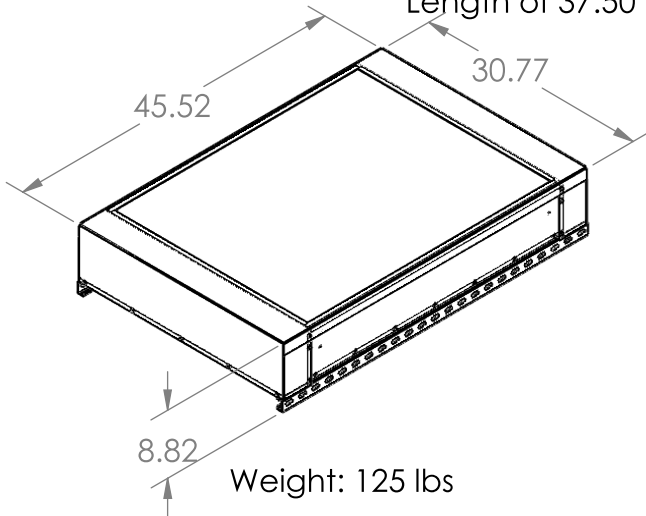

SLR-BX-05C50.00 V2

10.0 Ton
Solar Box

5 Heat Chambers
at a
Length of 50.00"
Unistrut Mounting

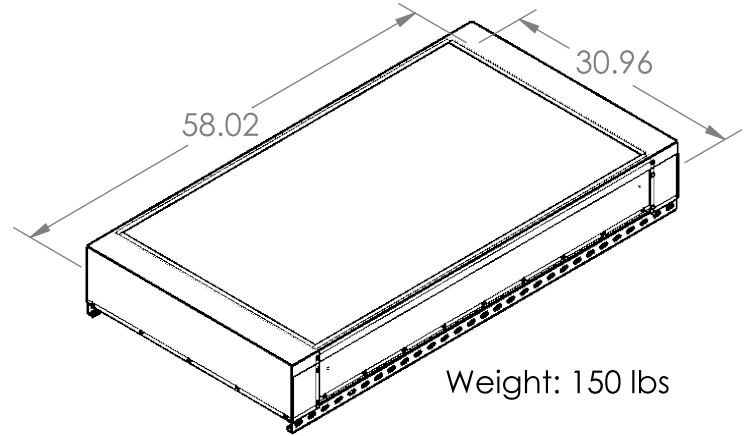

SLR-BX-05C75.00 V2

15.0 Ton
Solar Box

5 Heat Chambers
at a
Length of 75.00"
Unistrut Mounting

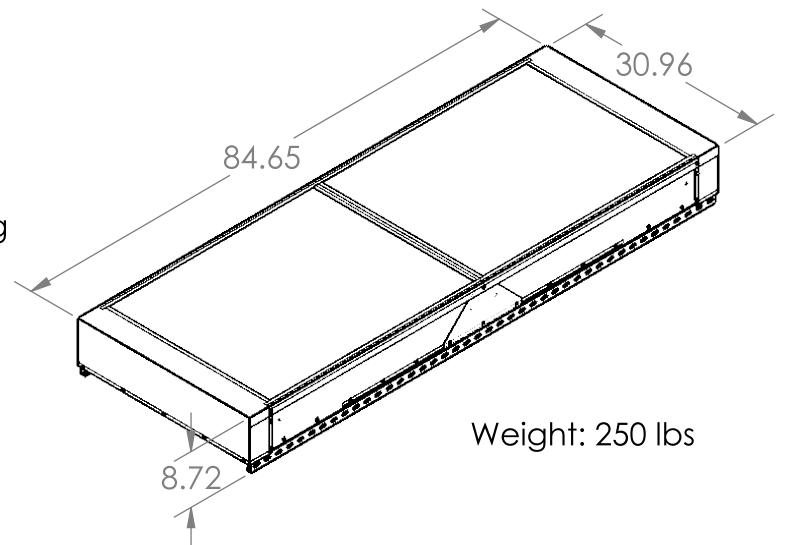

SLR-MNT-XXC31.50-185042 - 3.75-Ton Dimensions

This part number contains strut mounting frame and hardware only. Solar Boxes, plumbing, and electric Hardware are ordered under the Solar HVAC Kit Part Number.

Notes:

1. Face solar panels south for optimal performance.
2. Total Weight = 100lbs (Dry)
3. Plumbing sized for liquid line.
4. Standard Split System piping requirements apply; contact factory for systems greater than 100ft.

The Universal Solar HVAC Mounting Frame is designed for a general HVAC commercial unit. Pieces will be longer than needed; cut to width and height of HVAC unit. 2" Lengths preferred as to not cut into the slots.

All strut channel framing is adjustable. Typical install positioning shown.

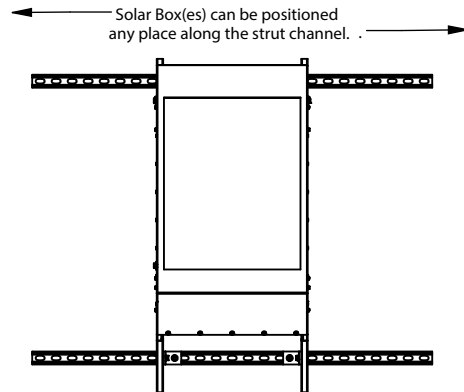
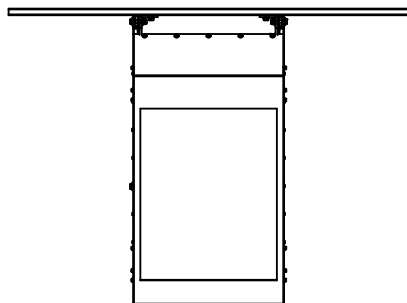
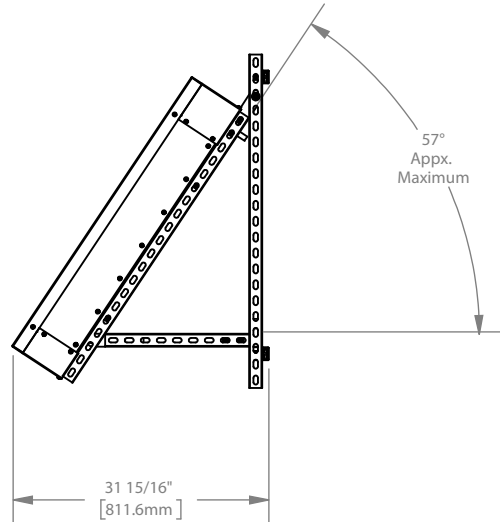
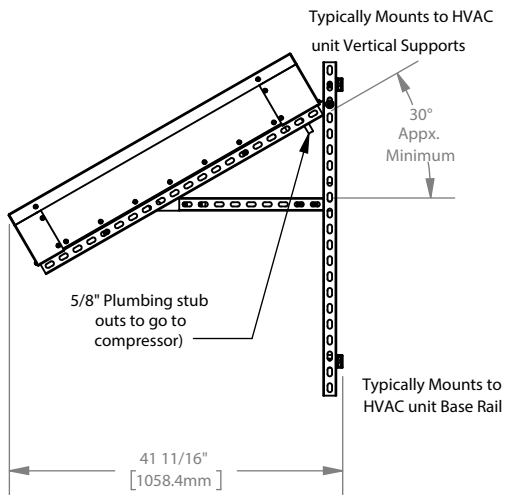
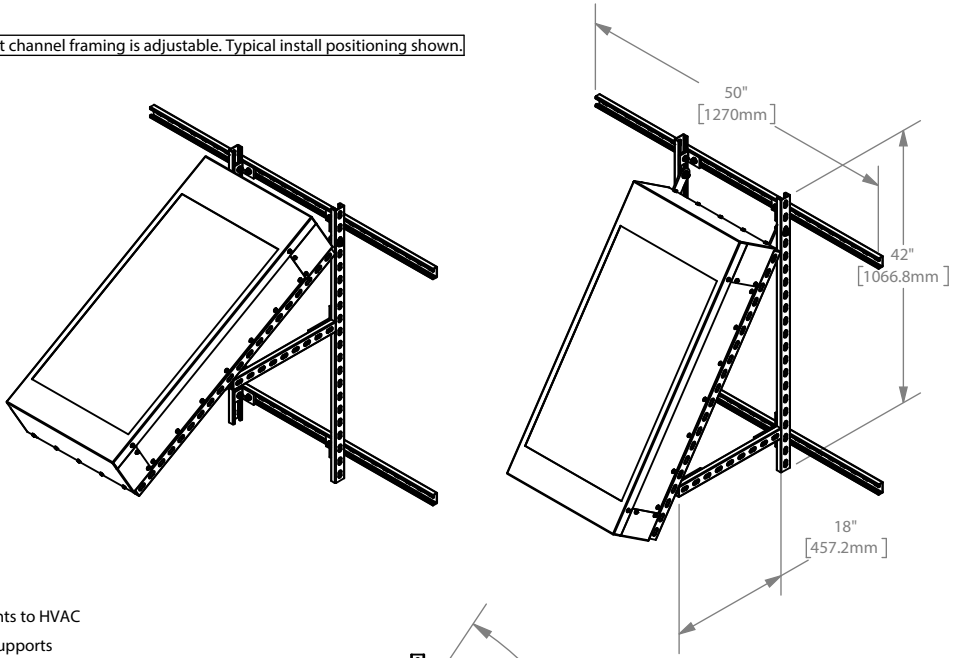

SLR-MNT-xxC31.50-185448 - 5.00-Ton Dimensions

This part number contains strut mounting frame and hardware only. Solar Boxes, plumbing, and electric Hardware are ordered under the Solar HVAC Kit Part Number.

All struct channel framing is adjustable. Typical install positioning shown.

Notes:

1. Face solar panels south for optimal performance.
2. Total Weight = 125lbs (Dry)
3. Plumbing sized for liquid line.
4. Standard Split System piping requirements apply; contact factory for systems greater than 100ft.

The Universal Solar HVAC Mounting Frame is designed for a general HVAC commercial unit. Pieces will be longer than needed; cut to width and height of HVAC unit. 2" Lengths preferred as to not cut into the slots.

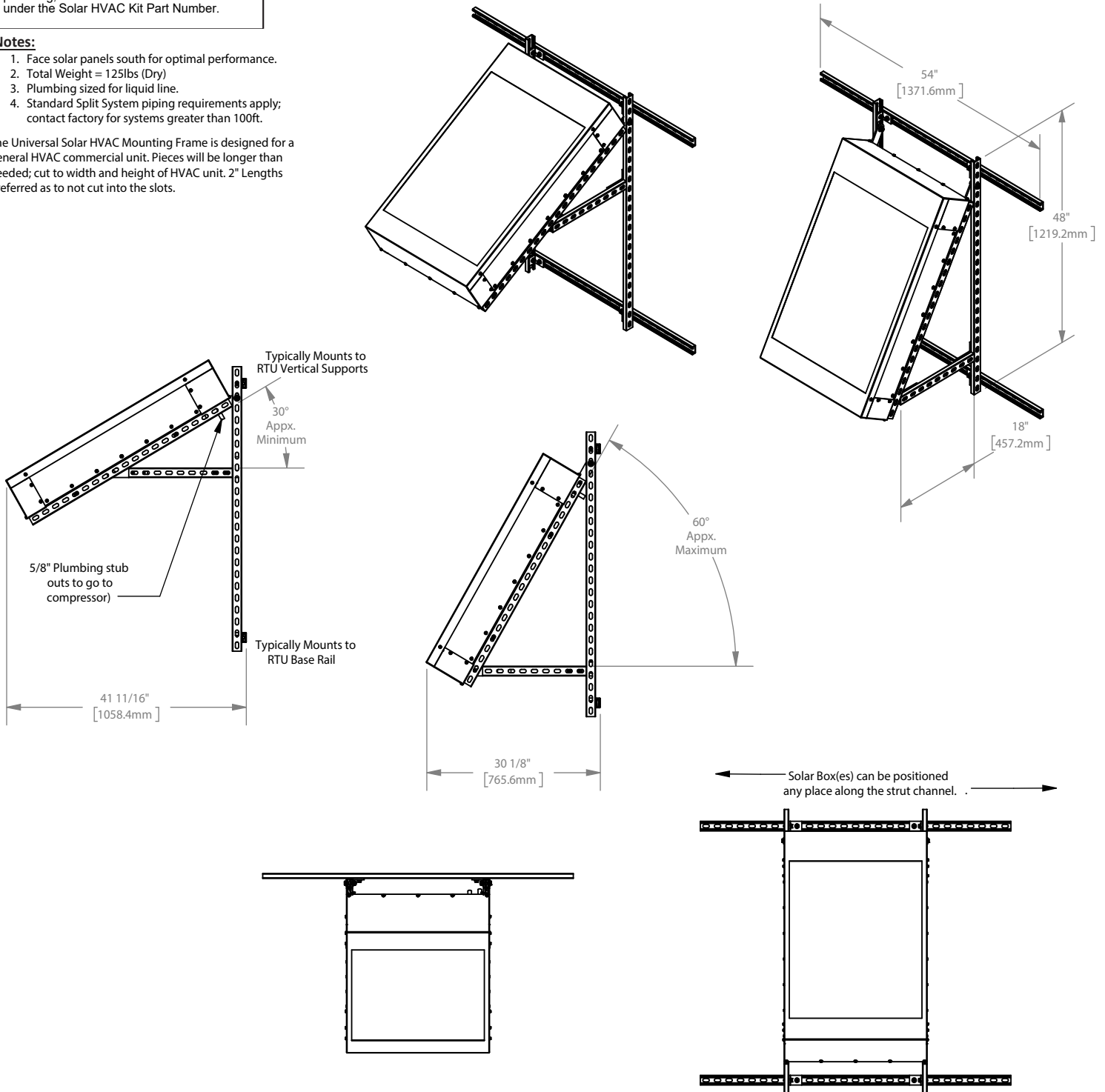

SLR-MNT-XXC31.50-186052-2 - 7.50-Ton Dimensions

This part number contains strut mounting frame and hardware only. Solar Boxes, plumbing, and electric Hardware are ordered under the Solar HVAC Kit Part Number.

All struct channel framing is adjustable. Typical install positioning shown.

Notes:

1. Face solar panels south for optimal performance.
2. Total Weight = 200lbs (Dry)
3. Plumbing sized for liquid line.
4. Standard Split System piping requirements apply; contact factory for systems greater than 100ft.

The Universal Solar HVAC Mounting Frame is designed for a general HVAC commercial unit. Pieces will be longer than needed; cut to width and height of HVAC unit. 2" Lengths preferred as to not cut into the slots.

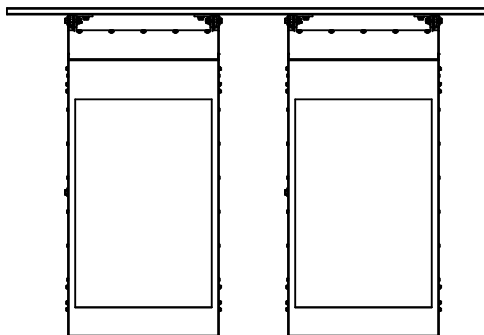
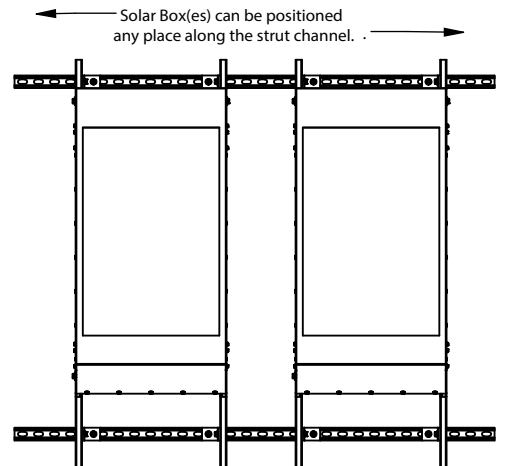
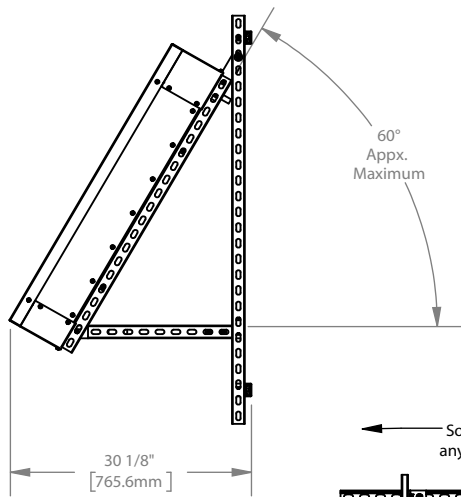
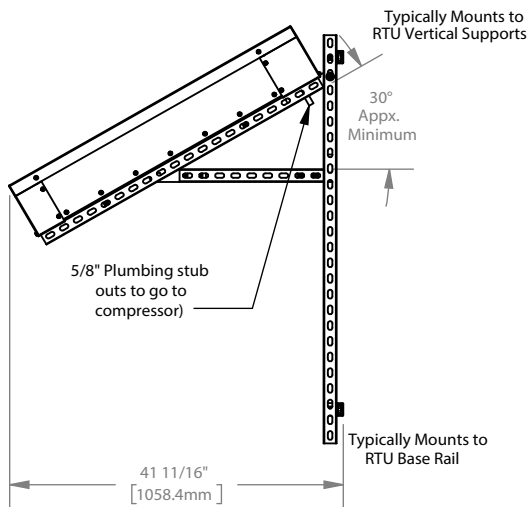
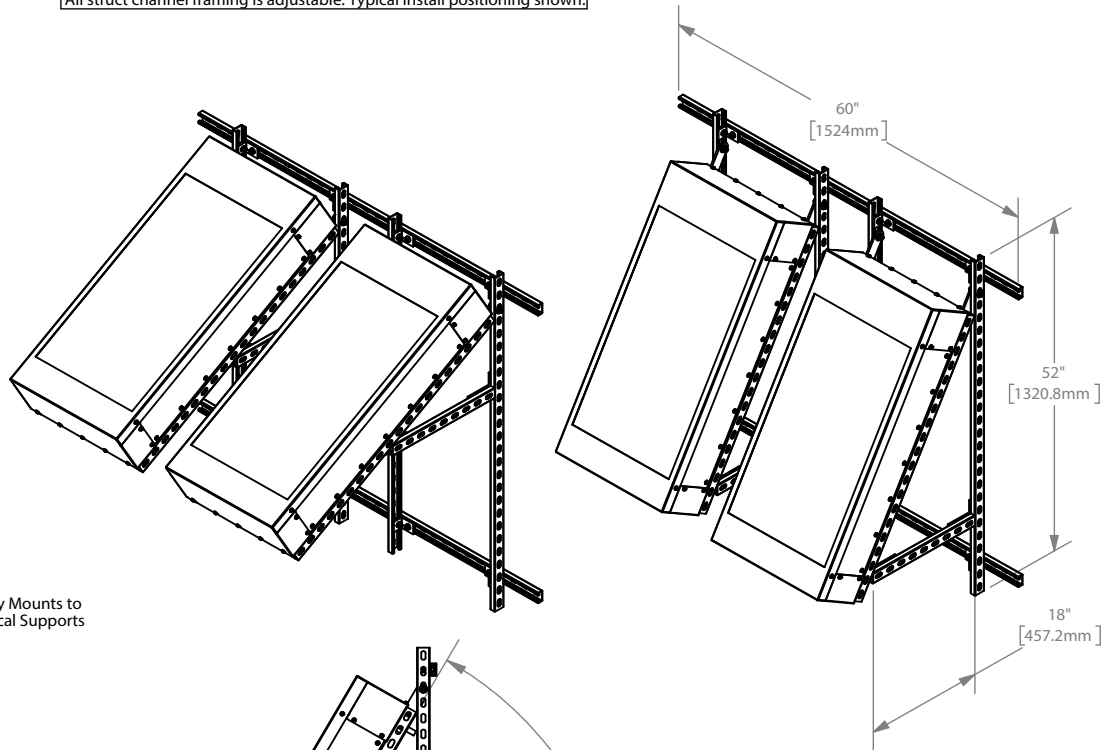

SLR-MNT-xxC31.50-186458-2 - 10.0-Ton Dimensions

This part number contains strut mounting frame and hardware only. Solar Boxes, plumbing, and electric Hardware are ordered under the Solar HVAC Kit Part Number.

All struct channel framing is adjustable. Typical install positioning shown.

Notes:

1. Face solar panels south for optimal performance.
2. Total Weight = 245lbs (Dry)
3. Plumbing sized for liquid line.
4. Standard Split System piping requirements apply; contact factory for systems greater than 100ft.

The Universal Solar HVAC Mounting Frame is designed for a general HVAC commercial unit. Pieces will be longer than needed; cut to width and height of HVAC unit. 2" Lengths preferred as to not cut into the slots.

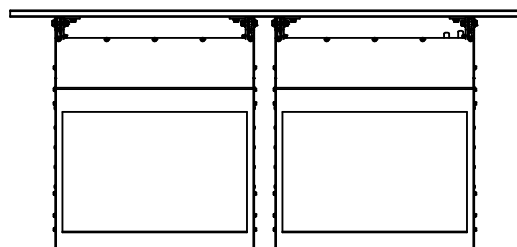
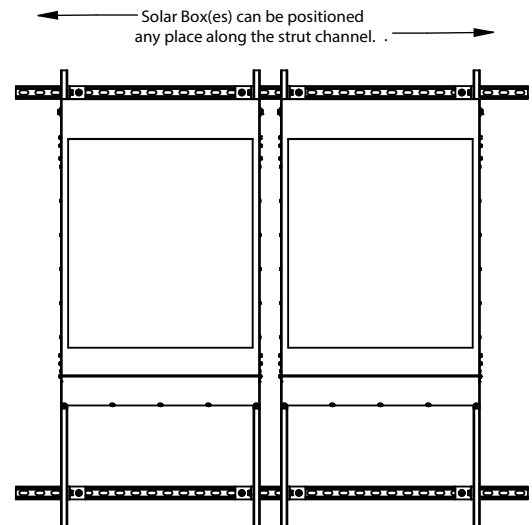
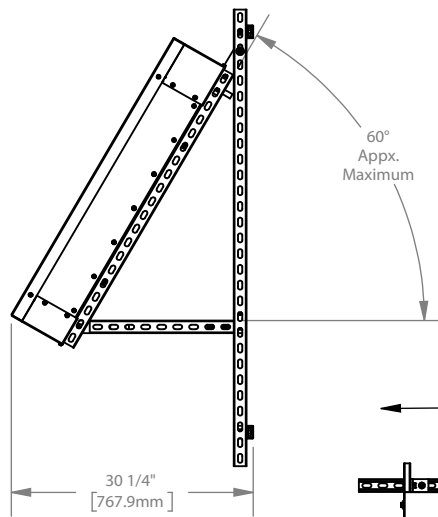
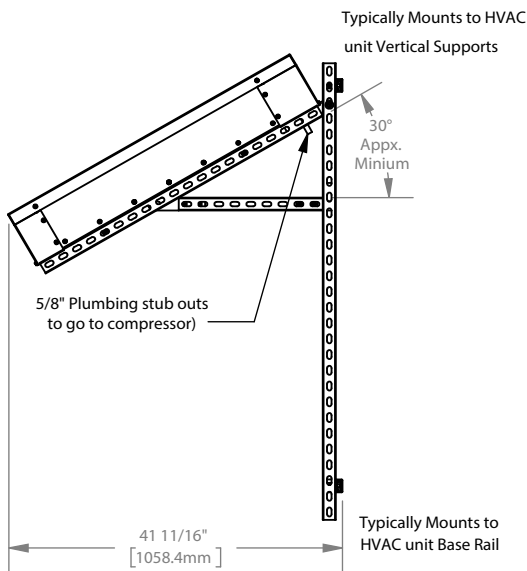
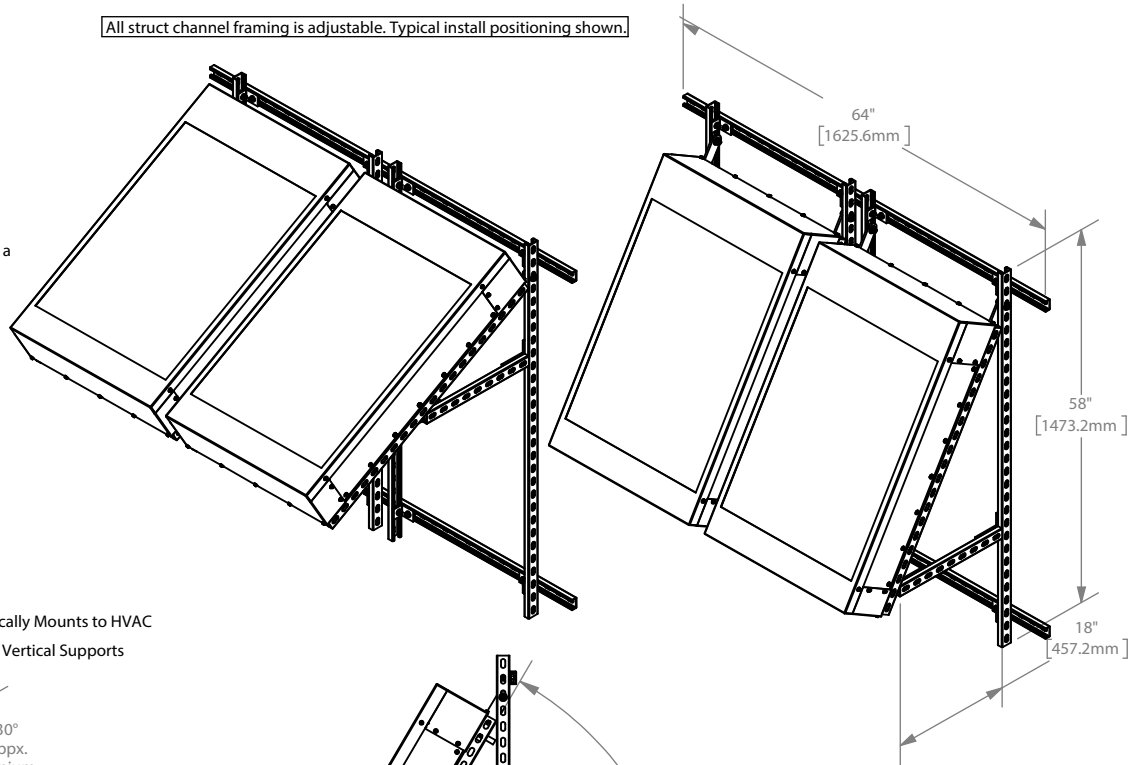

SLR-MNT-xxC37.50-206052 - 7.50-Ton Dimensions

This part number contains strut mounting frame and hardware only. Solar Boxes, plumbing, and electric Hardware are ordered under the Solar HVAC Kit Part Number.

All struct channel framing is adjustable. Typical install positioning shown.

Notes:

1. Face solar panels south for optimal performance.
2. Total Weight = 125lbs (Dry)
3. Plumbing sized for liquid line.
4. Standard Split System piping requirements apply; contact factory for systems greater than 100ft.

The Universal Solar HVAC Mounting Frame is designed for a general HVAC commercial unit. Pieces will be longer than needed; cut to width and height of HVAC unit. 2" Lengths preferred as to not cut into the slots.

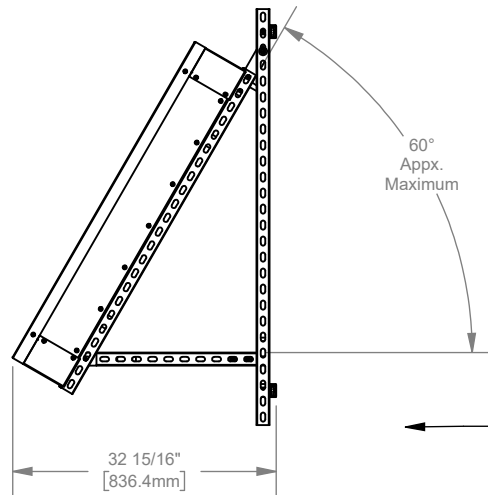
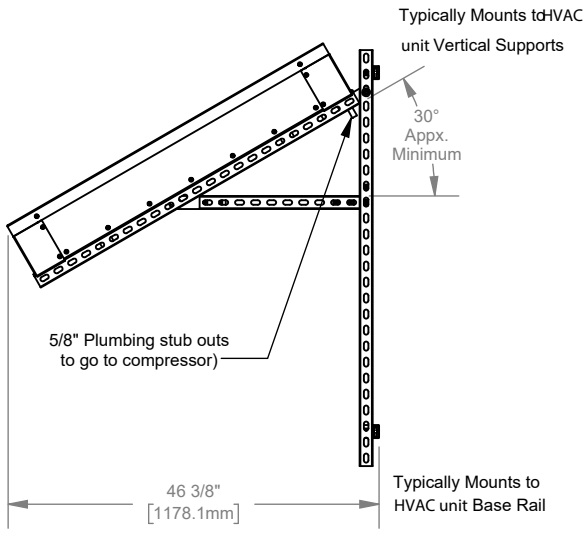
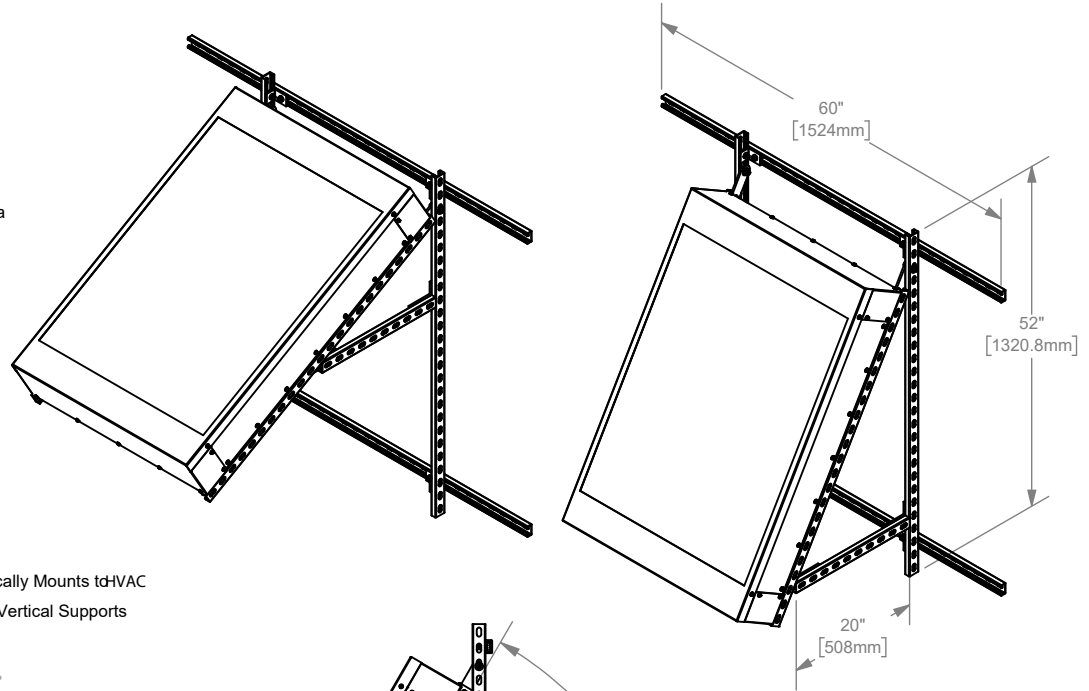

Solar Box(es) can be positioned any place along the strut channel.

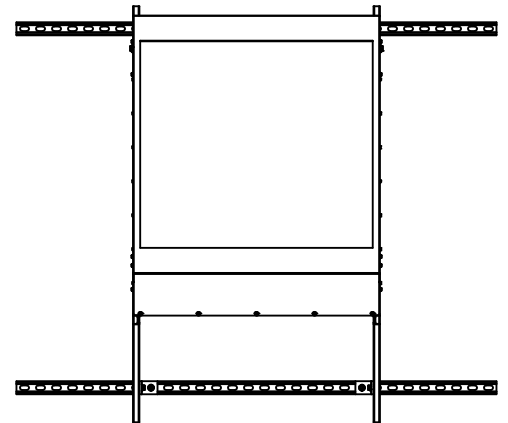
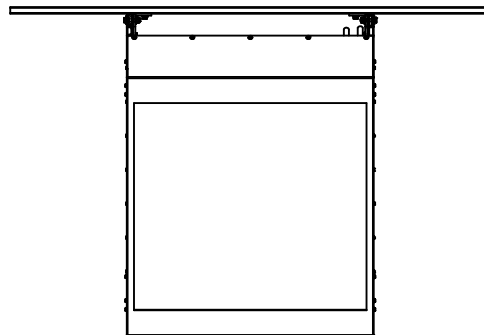

SLR-MNT-xxC37.50-209266-2 - 15.0-Ton Dimensions

This part number contains strut mounting frame and hardware only. Solar Boxes, plumbing, and electric Hardware are ordered under the Solar HVAC Kit Part Number.

All strut channel framing is adjustable. Typical install positioning shown.

Notes:

1. Face solar panels south for optimal performance.
2. Total Weight =305lbs (Dry)
3. Plumbing sized for liquid line.
4. Standard Split System piping requirements apply; contact factory for systems greater than 100ft.

The Universal Solar HVAC Mounting Frame is designed for a general HVAC commercial unit. Pieces will be longer than needed; cut to width and height of HVAC unit. 2" Lengths preferred as to not cut into the slots.

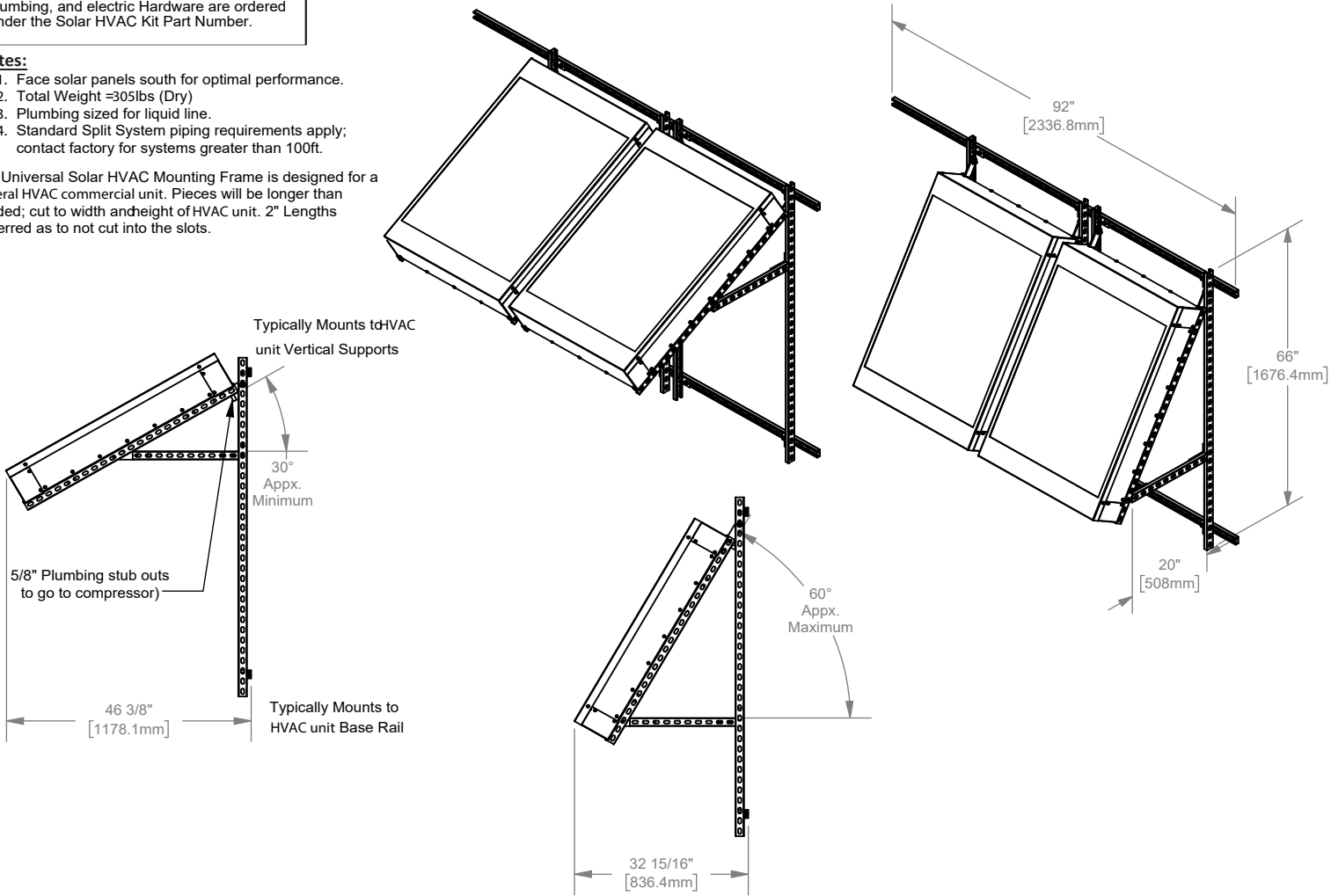

Solar Box(es) can be positioned any place along the strut channel.

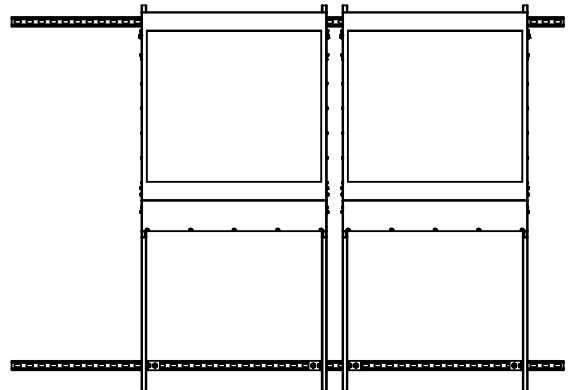
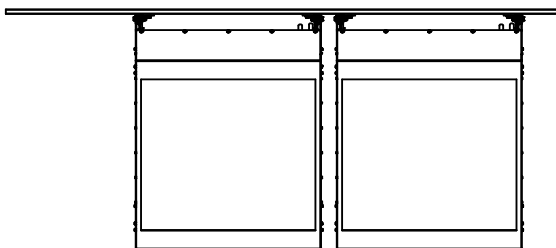

SLR-MNT-xxC50.00-266458 - 10.0-Ton Dimensions

This part number contains strut mounting frame and hardware only. Solar Boxes, plumbing, and electric Hardware are ordered under the Solar HVAC Kit Part Number.

All struct channel framing is adjustable. Typical install positioning shown.

Notes:

1. Face solar panels south for optimal performance.
2. Total Weight = 180lbs (Dry)
3. Plumbing sized for liquid line.
4. Standard Split System piping requirements apply; contact factory for systems greater than 100ft.

The Universal Solar HVAC Mounting Frame is designed for a general HVAC commercial unit. Pieces will be longer than needed; cut to width and height of HVAC unit. 2" Lengths preferred as to not cut into the slots.

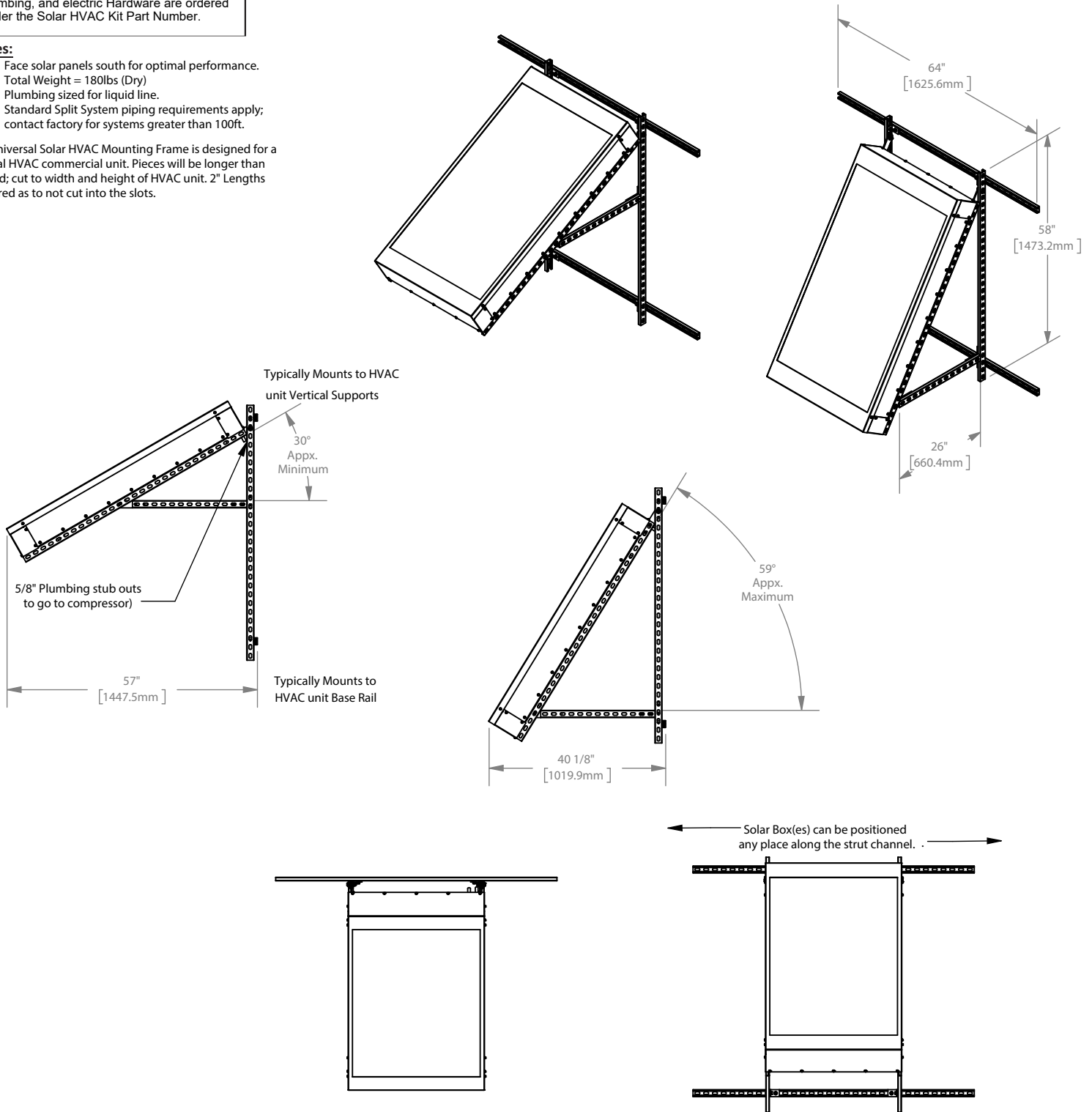

SLR-MNT-xxC50.00-269266-2 - 20.0-Ton Dimensions

All strut channel framing is adjustable. Typical install positioning shown.

This part number contains strut mounting frame and hardware only. Solar Boxes, plumbing, and electric Hardware are ordered under the Solar HVAC Kit Part Number.

Notes:

1. Face solar panels south for optimal performance.
2. Total Weight = 360lbs (Dry)
3. Plumbing sized for liquid line.
4. Standard Split System piping requirements apply; contact factory for systems greater than 100ft.

The Universal Solar HVAC Mounting Frame is designed for a general HVAC commercial unit. Pieces will be longer than needed; cut to width and height of HVAC unit. 2" Lengths preferred as to not cut into the slots.

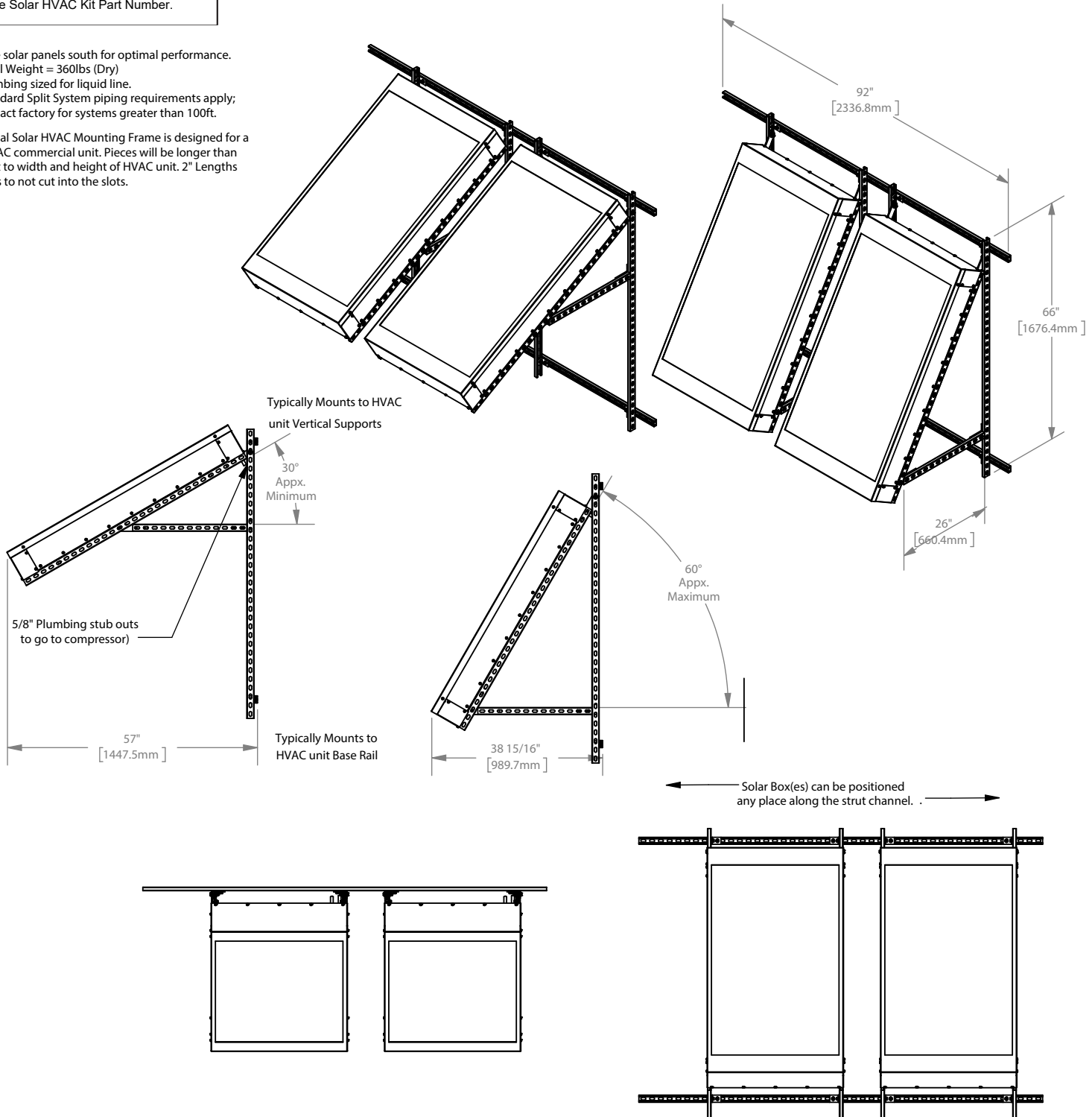

SLR-MNT-xxC75.00-409266 - 15.0-Ton Dimensions

This part number contains strut mounting frame and hardware only. Solar Boxes, plumbing, and electric Hardware are ordered under the Solar HVAC Kit Part Number.

All strut channel framing is adjustable. Typical install positioning shown.

Notes:

1. Face solar panels south for optimal performance.
2. Total Weight ≈315lbs (Dry)
3. Plumbing sized for liquid line.
4. Standard Split System piping requirements apply; contact factory for systems greater than 100ft.

The Universal Solar HVAC Mounting Frame is designed for a general HVAC commercial unit. Pieces will be longer than needed; cut to width and height of HVAC unit. 2" Lengths preferred as to not cut into the slots.

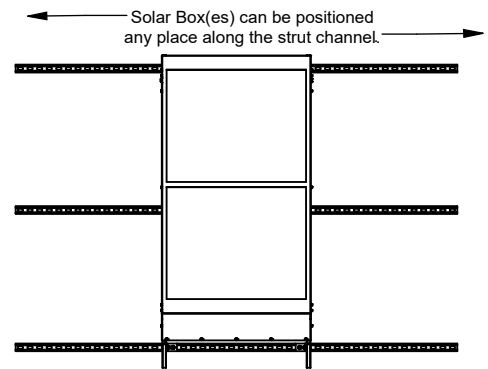
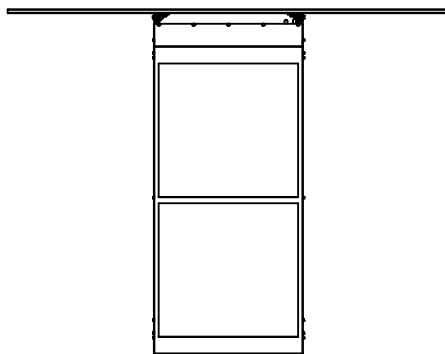
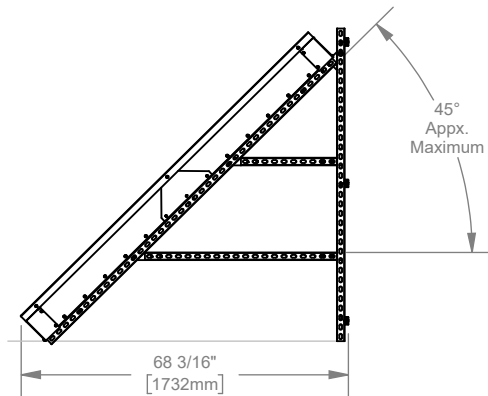
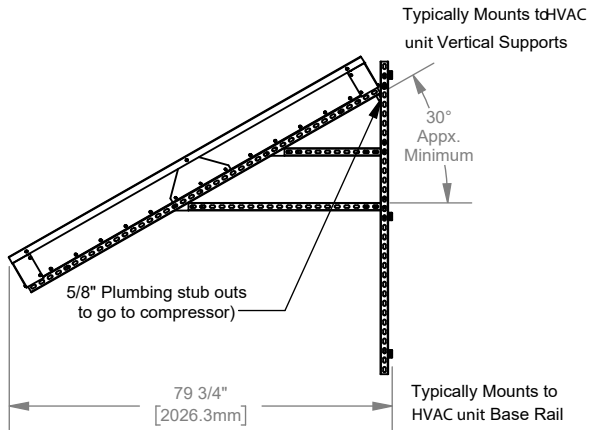
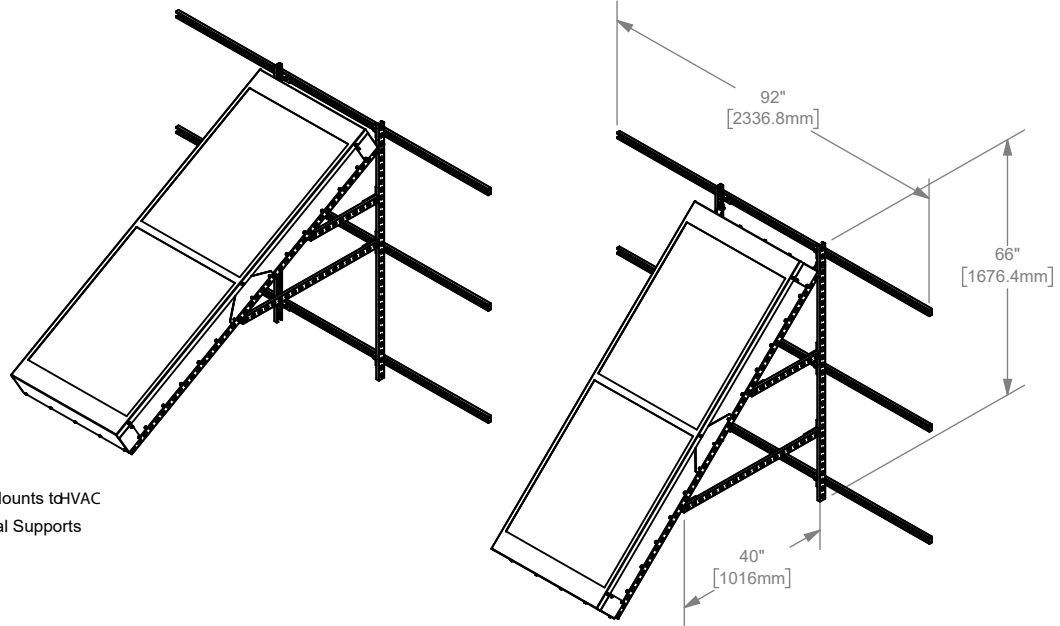

SLR-MNT-xxC75.00-409266-2 - 30.0-Ton Dimensions

This part number contains strut mounting frame and hardware only. Solar Boxes, plumbing, and electric Hardware are ordered under the Solar HVAC Kit Part Number.

All strut channel framing is adjustable. Typical install positioning shown.

Notes:

1. Face solar panels south for optimal performance.
2. Total Weight = 600lbs (Dry)
3. Plumbing sized for liquid line.
4. Standard Split System piping requirements apply; contact factory for systems greater than 100ft.

The Universal Solar HVAC Mounting Frame is designed for a general HVAC commercial unit. Pieces will be longer than needed; cut to width and height of HVAC unit. 2" Lengths preferred as to not cut into the slots.

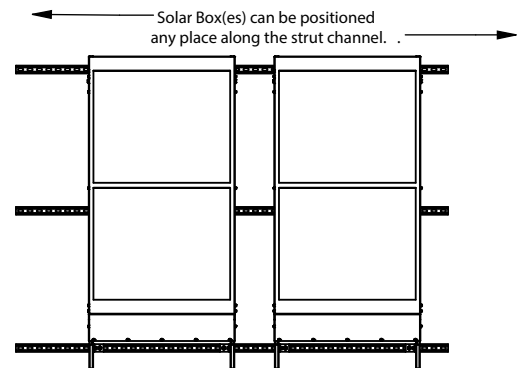
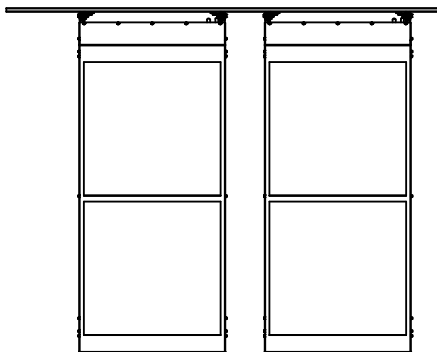
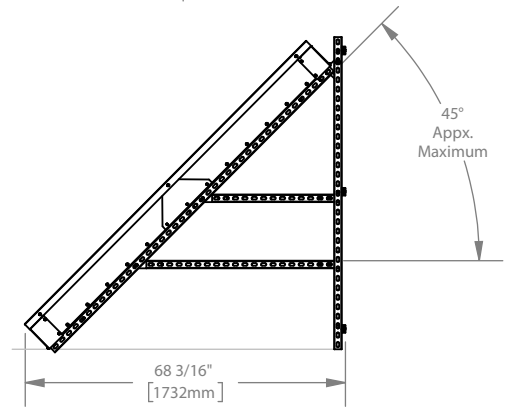
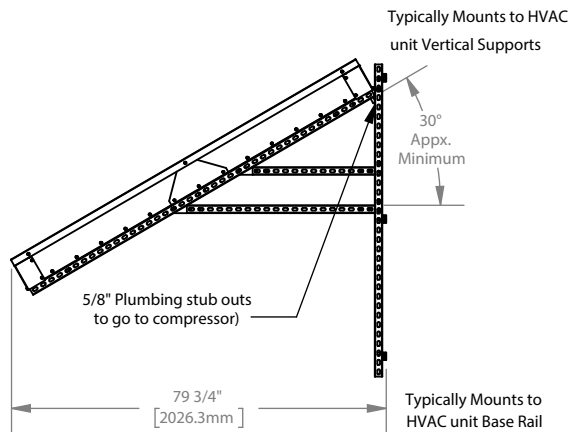
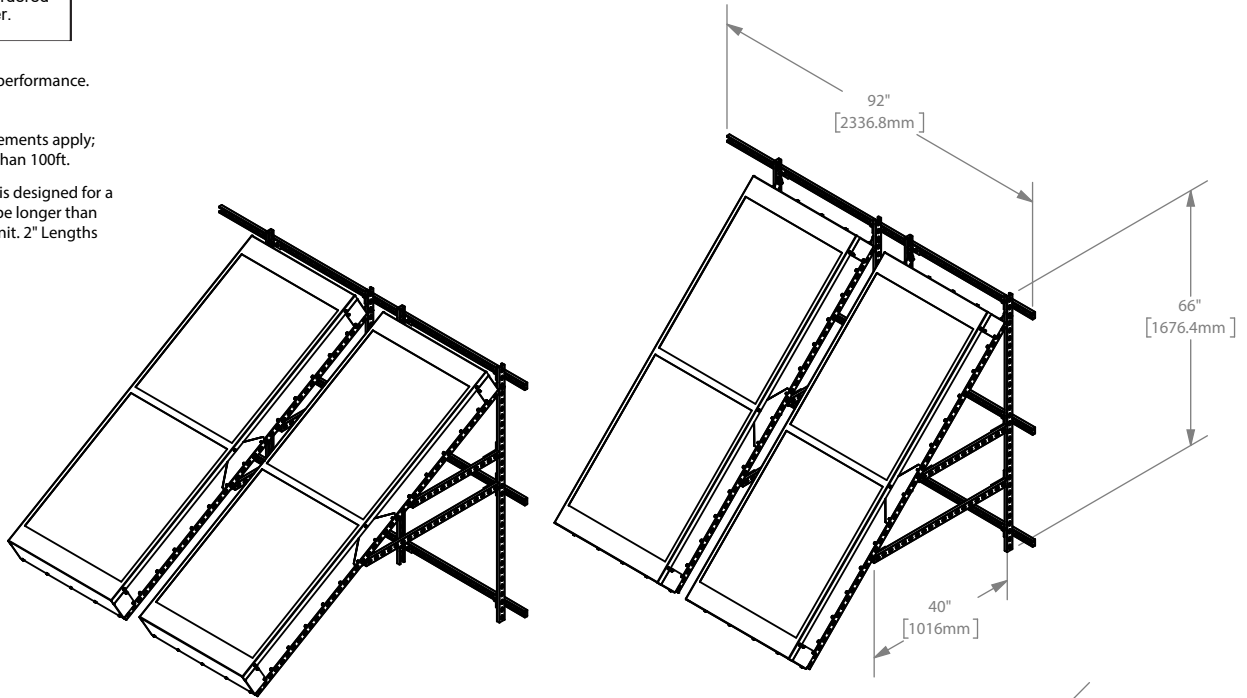

Solar Racks – Part Numbering Scheme

Solar Boxes

SLR-RCK-728836-DD – 20-Ton Rack (2 Solar Boxes)
 SLR-RCK-728836-DE – 25-Ton Rack (2 Solar Boxes)
 SLR-RCK-728836-EE – 30-Ton Rack (2 Solar Boxes)
 SLR-RCK-1088836-DDD – 30-Ton Rack (3 Solar Boxes)
 SLR-RCK-1088836-DED – 35-Ton Rack (3 Solar Boxes)
 SLR-RCK-1088836-EDE – 40-Ton Rack (3 Solar Boxes)
 SLR-RCK-1088836-EEE – 45-Ton Rack (3 Solar Boxes)
 SLR-RCK-1448836-DDDD – 40-Ton Rack (4 Solar Boxes)
 SLR-RCK-1448836-DEED – 45-Ton Rack (4 Solar Boxes)
 SLR-RCK-1448836-DEED – 50-Ton Rack (4 Solar Boxes)
 SLR-RCK-1448836-EEDE – 55-Ton Rack (4 Solar Boxes)
 SLR-RCK-1448836-EEEE – 60-Ton Rack (4 Solar Boxes)

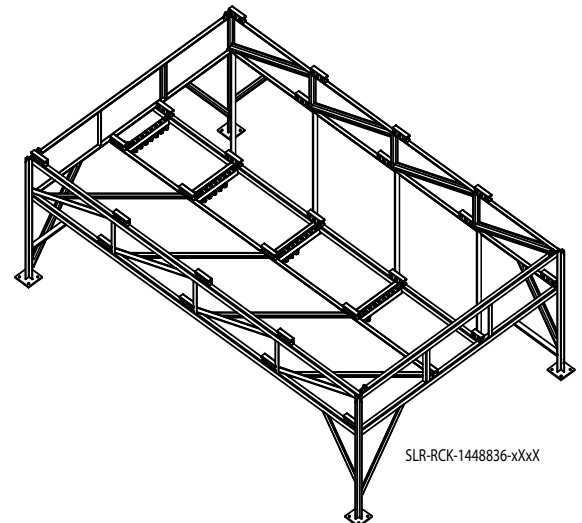
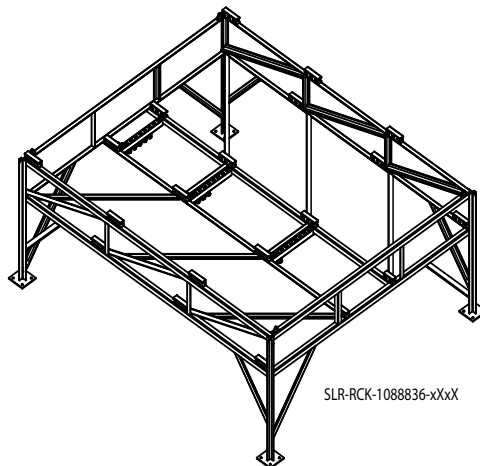
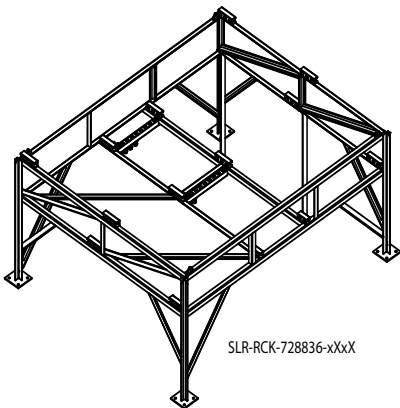

- Solar HVAC Mounting Racks allow mounting of Solar Boxes, in a sunny location, on any HVAC Unit over 30-Tons.
- The Solar Box(es) are sized for tonnage and number of circuits of the HVAC Unit and the paired rack is to be mounted on the roof next to the HVAC Unit. The solar boxes come at a fixed angle.
- Angle Iron mounting frame only. Solar Boxes, VFDs, ect. Are purchased as part of the complete unit kit (see page 6 of this IOM). Customer must provide their own plumbing equipment and lagging hardware.

Solar Racks with Solar Boxes Shown

Solar Box Mounting

Mounting solar boxes to the rack weldments. Each Solar boxes mount on all (4) corners and in (2) places in the middle front. Some adjustment, shims, rubber washers, gasket, etc. may be needed to line up middle mounting holes. Loosely place hardware in all mounting locations to line up and then tighten fully.

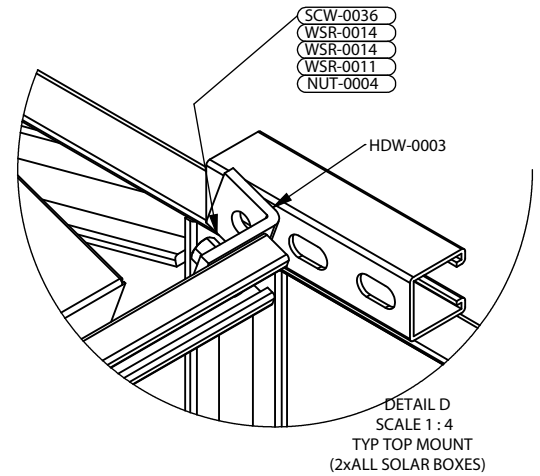
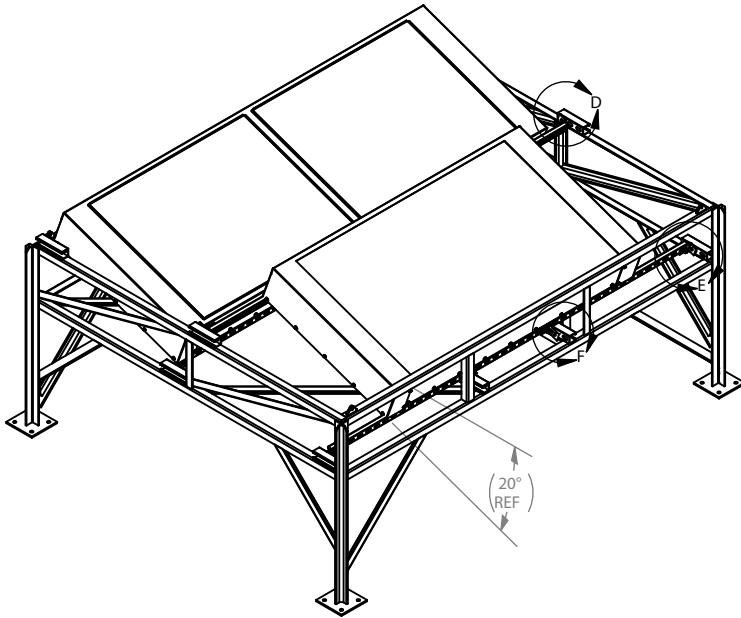

May need gasket or shims between solar strut channel and HDW-0011 in order to make slot align with rack strut channel.

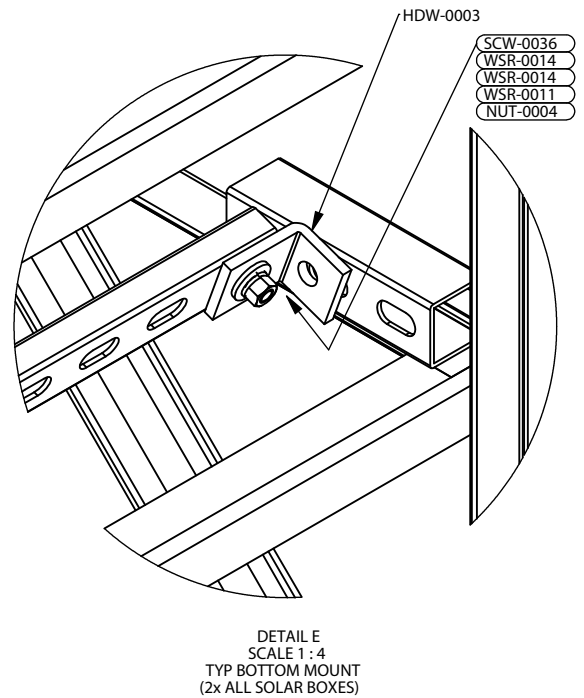
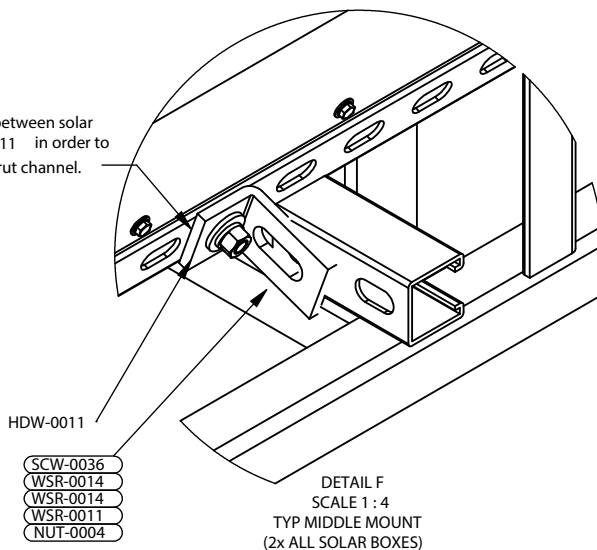

Solar Racks with Solar Boxes Shown (Cont'd)

Solar Rack (2) & (3) Box Layouts

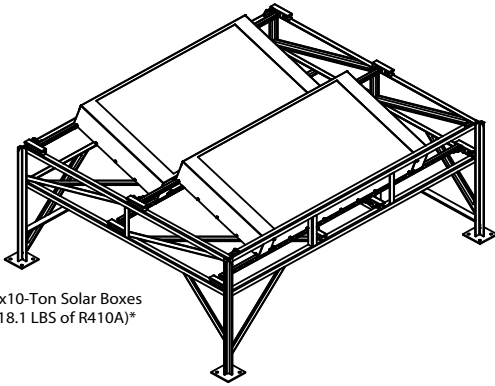

2x10-Ton Solar Boxes
(18.1 LBS of R410A)*

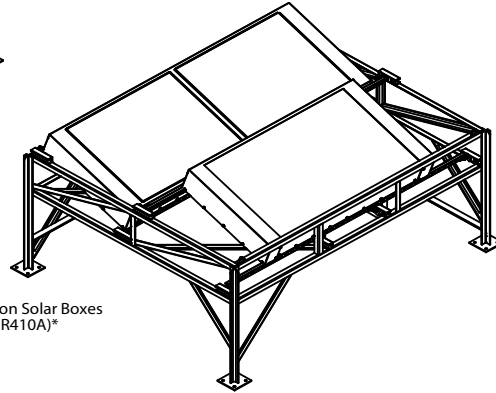

1x10-Ton + 1x15-Ton Solar Boxes
(21.5 LBS of R410A)*

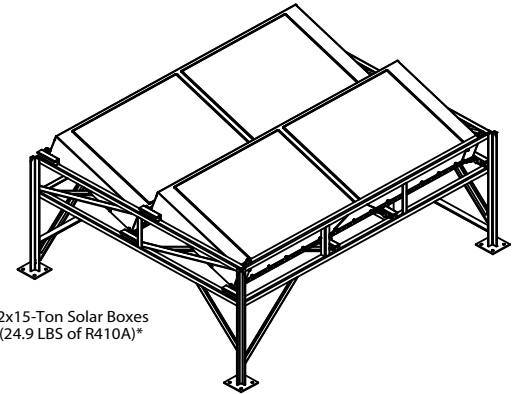

2x15-Ton Solar Boxes
(24.9 LBS of R410A)*

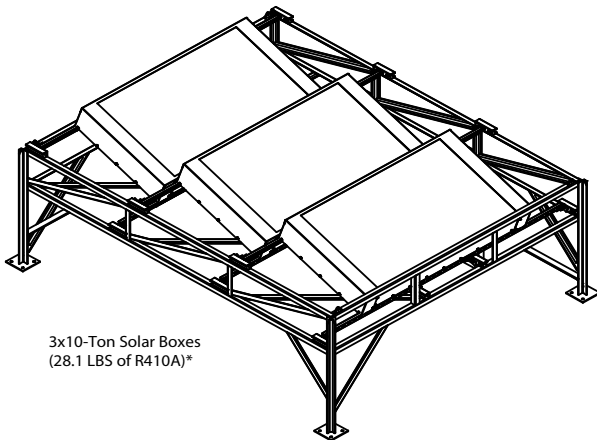

3x10-Ton Solar Boxes
(28.1 LBS of R410A)*

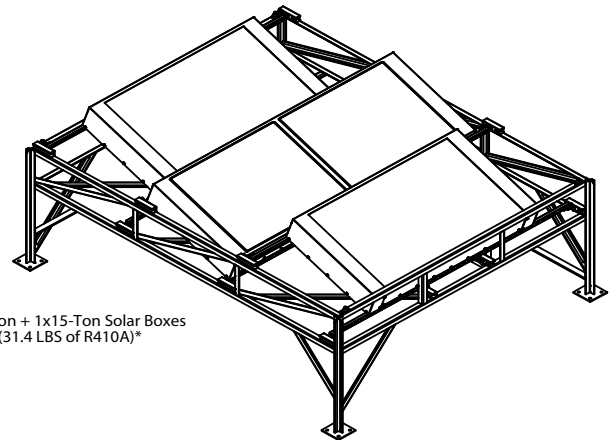

2x10-Ton + 1x15-Ton Solar Boxes
(31.4 LBS of R410A)*

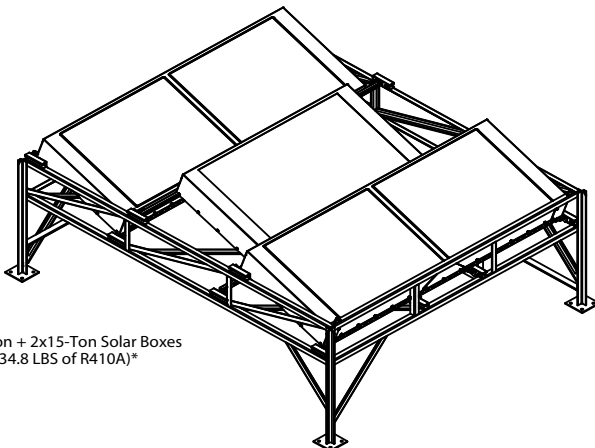

1x10-Ton + 2x15-Ton Solar Boxes
(34.8 LBS of R410A)*

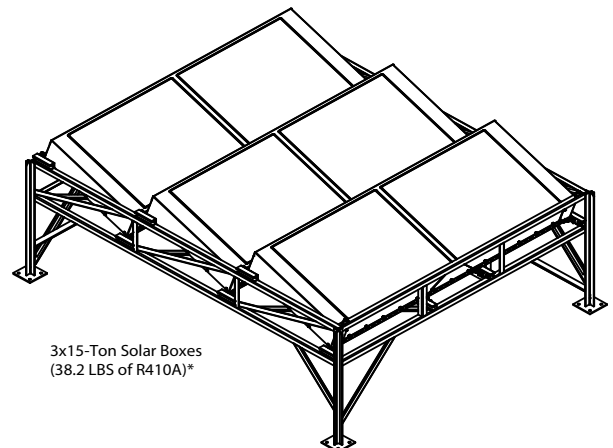

3x15-Ton Solar Boxes
(38.2 LBS of R410A)*

Standard Solar Box Layouts were chosen to approximately balance all cornerweights per Solar Rack Assembly.

Note*: Does not include the R410A needed to connect the Solar Rack to the RTU.

Solar Racks with Solar Boxes Shown (Cont'd)

Solar Rack (4) Box Layouts

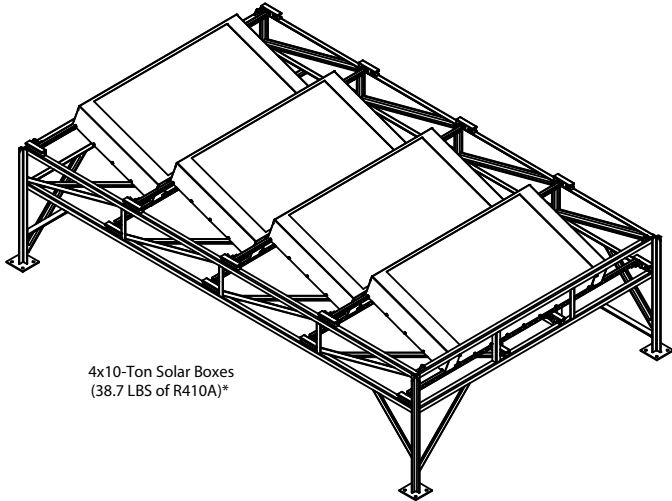

4x10-Ton Solar Boxes
(38.7 LBS of R410A)*

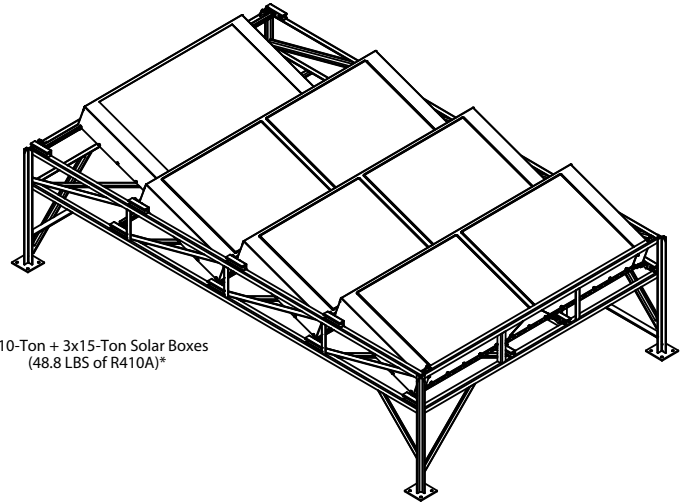

1x10-Ton + 3x15-Ton Solar Boxes
(48.8 LBS of R410A)*

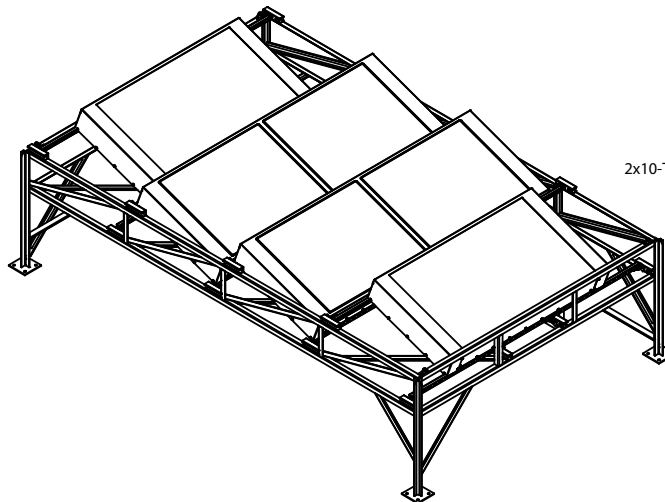

2x10-Ton + 2x15-Ton Solar Boxes
(45.4 LBS of R410A)*

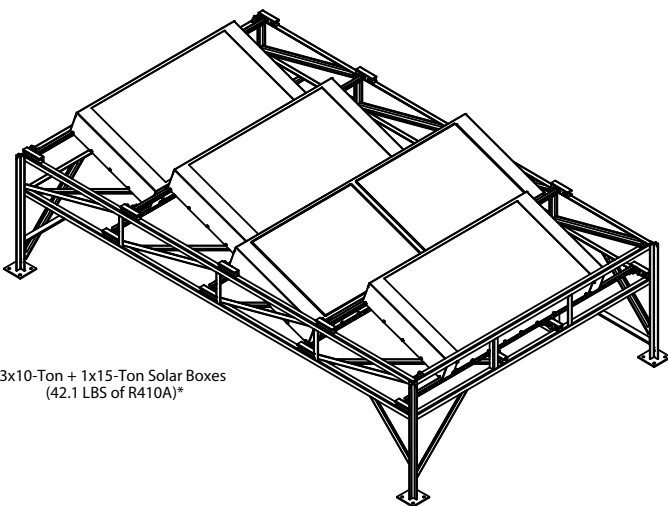

3x10-Ton + 1x15-Ton Solar Boxes
(42.1 LBS of R410A)*

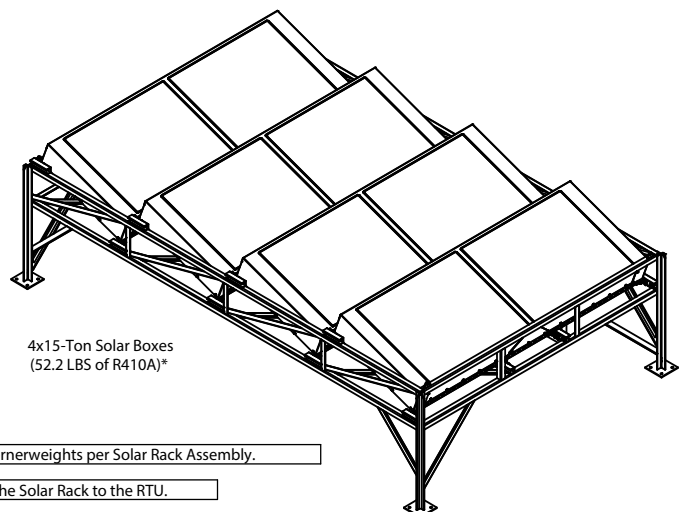

4x15-Ton Solar Boxes
(52.2 LBS of R410A)*

Standard Solar Box Layouts were chosen to approximately balance all cornerweights per Solar Rack Assembly.

Note*: Does not include the R410A needed to connect the Solar Rack to the RTU.

SLR-RCK-728836-(DD) – 20-Ton



Certification number:
10002093:

NOTES:

1. Face solar panels south for optimal performance.
2. Total Weight = 800 pounds (~200 lbs/corner); not including refrigerant
3. Plumbing sized for liquid line
4. Standard Split System piping requirements apply; contact factory for systems greater than 100ft.

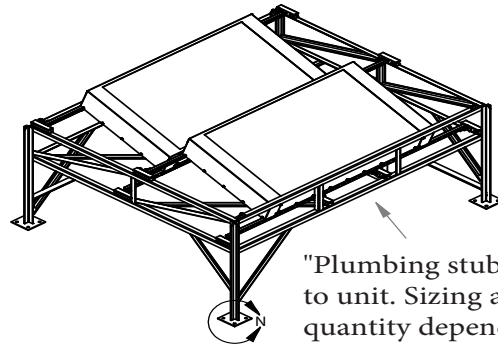

"Plumbing stubs to go to unit. Sizing and quantity depend upon the type of circuit selected."

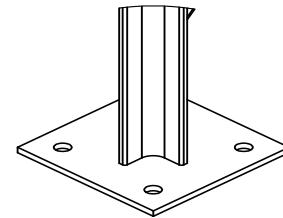
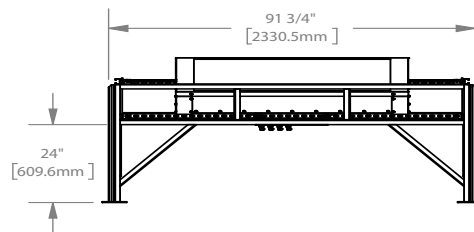

DETAIL N
SCALE 1 : 6

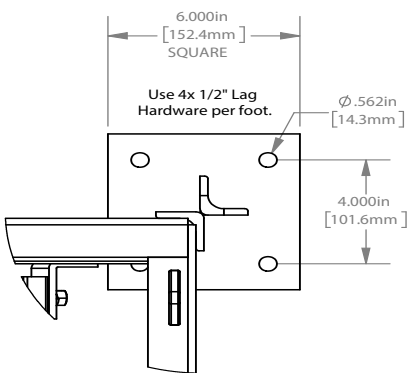
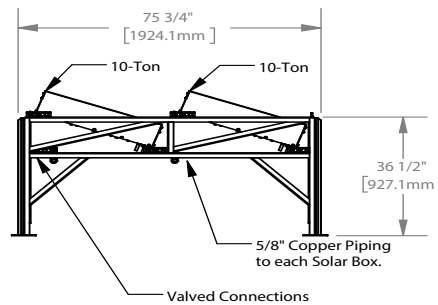
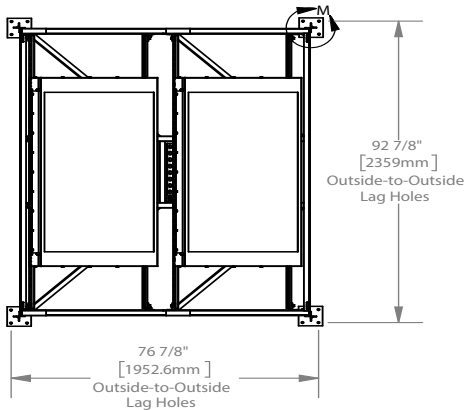

DETAIL M
SCALE 1 : 6

- Solar HVAC Mounting Racks allow mounting of Solar Boxes, in a sunny location, on any HVAC Unit over 30-Tons.
- The Solar Box(es) are sized for tonnage and number of circuits of the HVAC Unit and the paired rack is to be mounted on the roof next to the HVAC Unit. The solar boxes come at a fixed angle.
- Angle Iron mounting frame only. Solar Boxes, VFDs, ect. Are purchased as part of the complete unit kit (Reference IOM-0053). Customer must provide their own plumbing equipment and lagging hardware.

SLR-RCK-728836-(DE) – 25-Ton



Certification number:

10002093:

NOTES:

1. Face solar panels south for optimal performance.
2. Total Weight = 900 pounds (~225 lbs/corner); not including refrigerant
3. Plumbing sized for liquid line
4. Standard Split System piping requirements apply; contact factory for systems greater than 100ft.

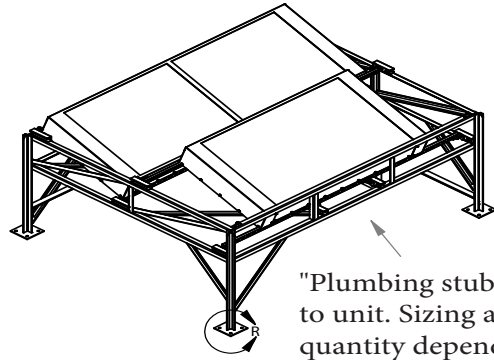

"Plumbing stubs to go to unit. Sizing and quantity depend upon the type of circuit selected."

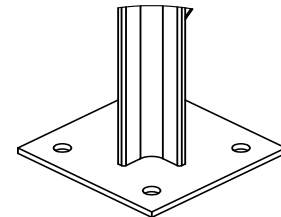
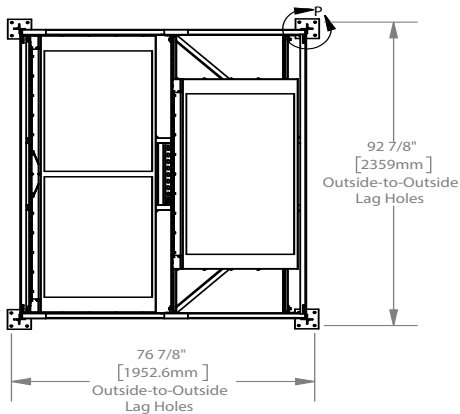
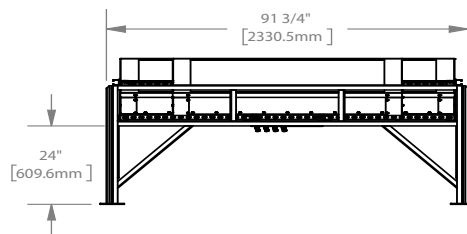

DETAIL R
SCALE 1 : 6

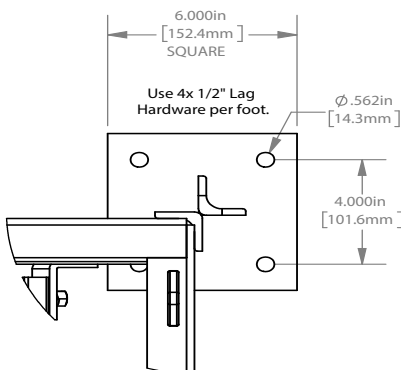
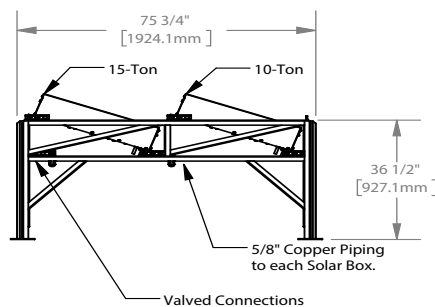

DETAIL P
SCALE 1 : 6

- Solar HVAC Mounting Racks allow mounting of Solar Boxes, in a sunny location, on any HVAC Unit over 30-Tons.
- The Solar Box(es) are sized for tonnage and number of circuits of the HVAC Unit and the paired rack is to be mounted on the roof next to the HVAC Unit. The solar boxes come at a fixed angle.
- Angle Iron mounting frame only. Solar Boxes, VFDs, ect. Are purchased as part of the complete unit kit (Reference IOM-0053). Customer must provide their own plumbing equipment and lagging hardware.

SLR-RCK-728836-(EE) – 30-Ton



Certification number:
10002093

NOTES:

1. Face solar panels south for optimal performance.
2. Total Weight = 1000 pounds (~250 lbs/corner); not including refrigerant
3. Plumbing sized for liquid line
4. Standard Split System piping requirements apply; contact factory for systems greater than 100ft.

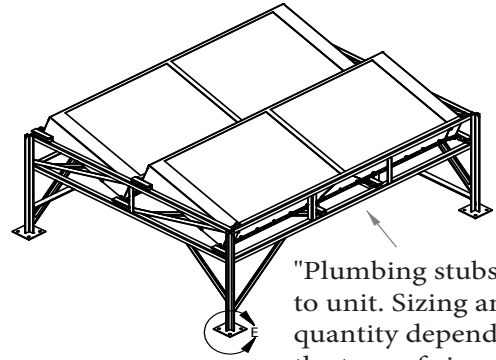

"Plumbing stubs to go to unit. Sizing and quantity depend upon the type of circuit selected."

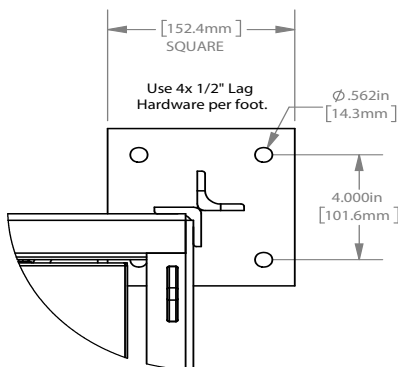
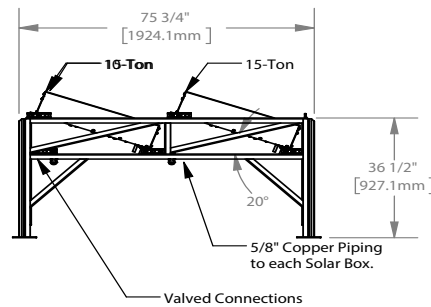
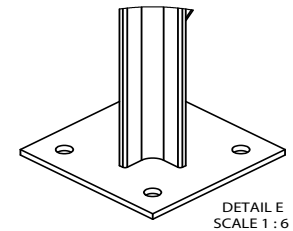
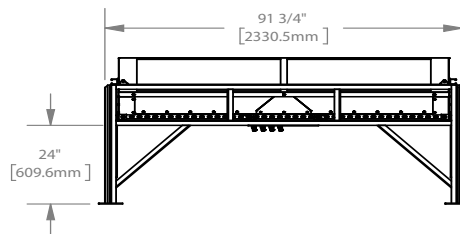
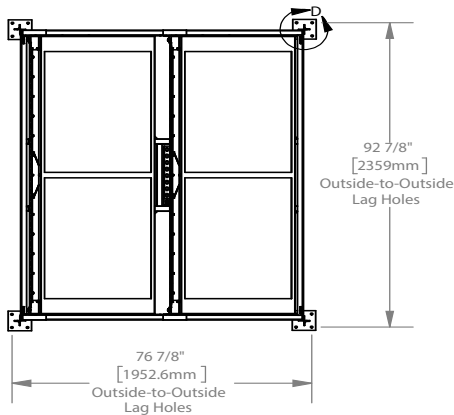

- Solar HVAC Mounting Racks allow mounting of Solar Boxes, in a sunny location, on any HVAC Unit over 30-Tons.
- The Solar Box(es) are sized for tonnage and number of circuits of the HVAC Unit and the paired rack is to be mounted on the roof next to the HVAC Unit. The solar boxes come at a fixed angle.
- Angle Iron mounting frame only. Solar Boxes, VFDs, ect. Are purchased as part of the complete unit kit (Reference IOM-0053). Customer must provide their own plumbing equipment and lagging hardware.

SLR-RCK-1088836-(DDD)- 30-Ton



Certification number:
10002093:

NOTES:

1. Face solar panels south for optimal performance.
2. Total Weight = 1200 pounds (~300 lbs/corner); not including refrigerant
3. Plumbing sized for liquid line
4. Standard Split System piping requirements apply; contact factory for systems greater than 100ft.

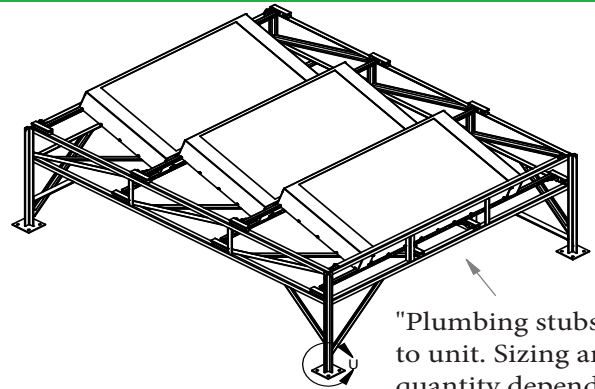

"Plumbing stubs to go to unit. Sizing and quantity depend upon the type of circuit selected."

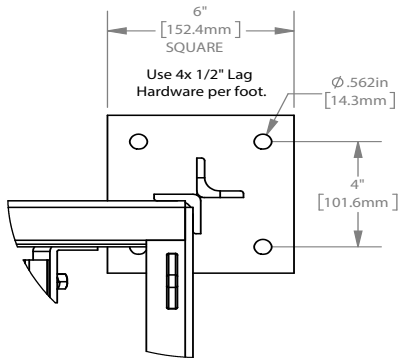
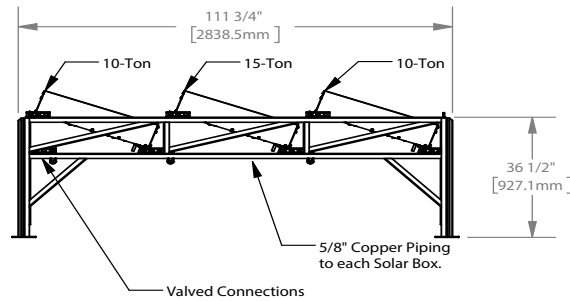
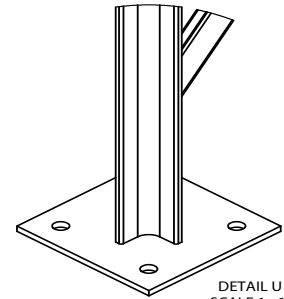
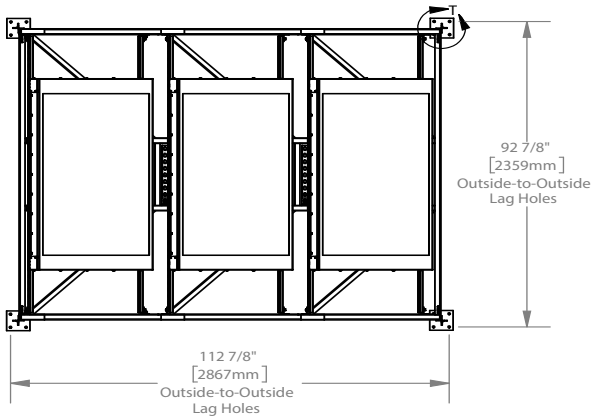
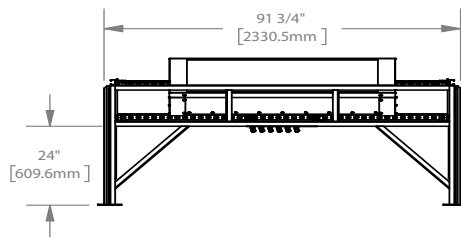

DETAIL T
SCALE 1 : 6

- Solar HVAC Mounting Racks allow mounting of Solar Boxes, in a sunny location, on any HVAC Unit over 30-Tons.
- The Solar Box(es) are sized for tonnage and number of circuits of the HVAC Unit and the paired rack is to be mounted on the roof next to the HVAC Unit. The solar boxes come at a fixed angle.
- Angle Iron mounting frame only. Solar Boxes, VFDs, ect. Are purchased as part of the complete unit kit (Reference IOM-0053). Customer must provide their own plumbing equipment and lagging hardware.

SLR-RCK-1088836-(DED) – 35-Ton



Certification number:
10002093

NOTES:

1. Face solar panels south for optimal performance.
2. Total Weight = 1200 pounds (~300 lbs/corner); not including refrigerant
3. Plumbing sized for liquid line
4. Standard Split System piping requirements apply; contact factory for systems greater than 100ft.

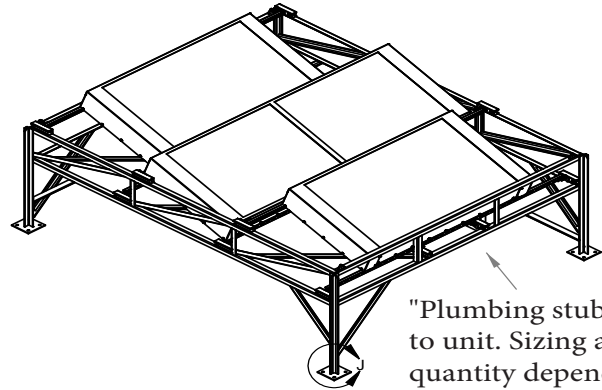

"Plumbing stubs to go to unit. Sizing and quantity depend upon the type of circuit selected."

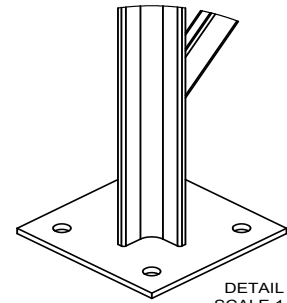
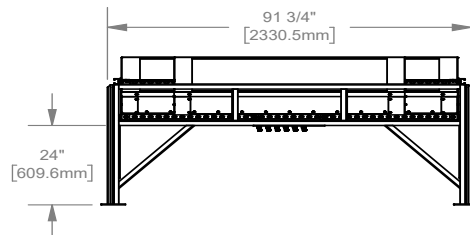

DETAIL J
SCALE 1 : 6

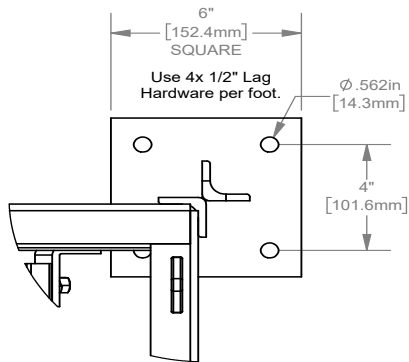
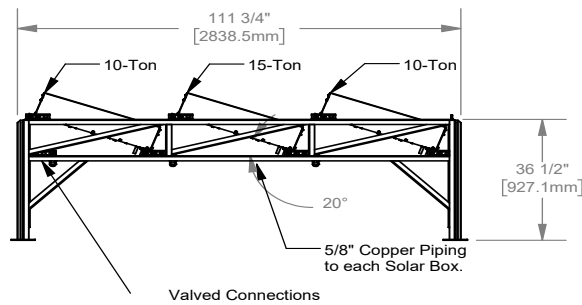
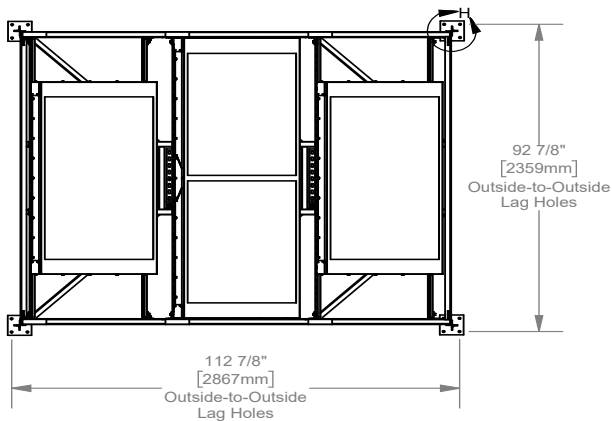

DETAIL H
SCALE 1 : 6

- Solar HVAC Mounting Racks allow mounting of Solar Boxes, in a sunny location, on any HVAC Unit over 30-Tons.
- The Solar Box(es) are sized for tonnage and number of circuits of the HVAC Unit and the paired rack is to be mounted on the roof next to the HVAC Unit. The solar boxes come at a fixed angle.
- Angle Iron mounting frame only. Solar Boxes, VFDs, ect. Are purchased as part of the complete unit kit (Reference IOM-0053). Customer must provide their own plumbing equipment and lagging hardware.

SLR-RCK-1088836-(EDE) – 40-Ton



Certification number:
10002093

Notes:

1. Face solar panels south for optimal performance.
2. Total Weight = 1250 pounds (~315 lbs/corner); not including refrigerant
3. Plumbing sized for liquid line
4. Standard Split System piping requirements apply; contact factory for systems greater than 100ft.

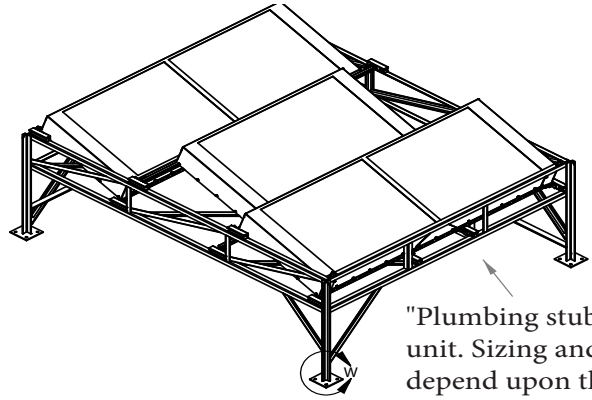

"Plumbing stubs to go to unit. Sizing and quantity depend upon the type of circuit selected."

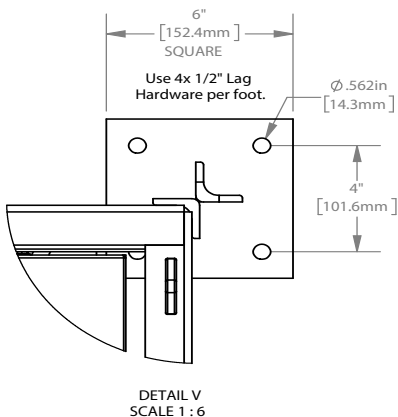
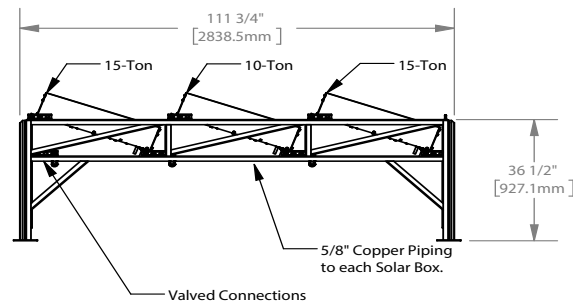
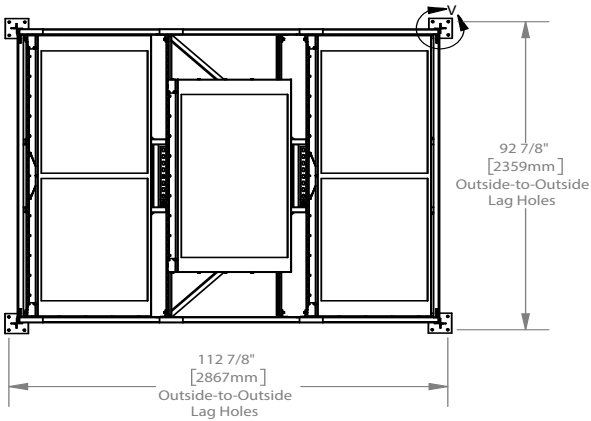
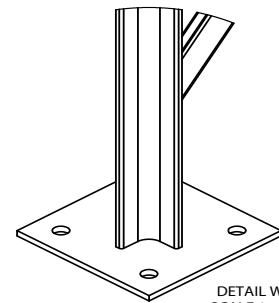
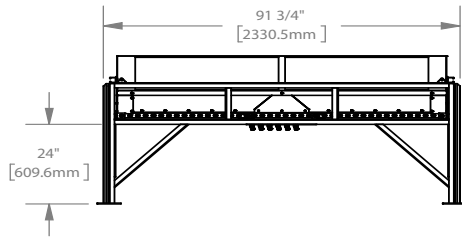

- Solar HVAC Mounting Racks allow mounting of Solar Boxes, in a sunny location, on any HVAC Unit over 30-Tons.
- The Solar Box(es) are sized for tonnage and number of circuits of the HVAC Unit and the paired rack is to be mounted on the roof next to the HVAC Unit. The solar boxes come at a fixed angle.
- Angle Iron mounting frame only. Solar Boxes, VFDs, ect. Are purchased as part of the complete unit kit (Reference IOM-0053). Customer must provide their own plumbing equipment and lagging hardware.

SLR-RCK-1088836-(EEE) – 45-Ton



Certification number:
10002093:

NOTES:

1. Face solar panels south for optimal performance.
2. Total Weight = 1300 pounds (~325 lbs/corner); not including refrigerant
3. Plumbing sized for liquid line
4. Standard Split System piping requirements apply; contact factory for systems greater than 100ft.

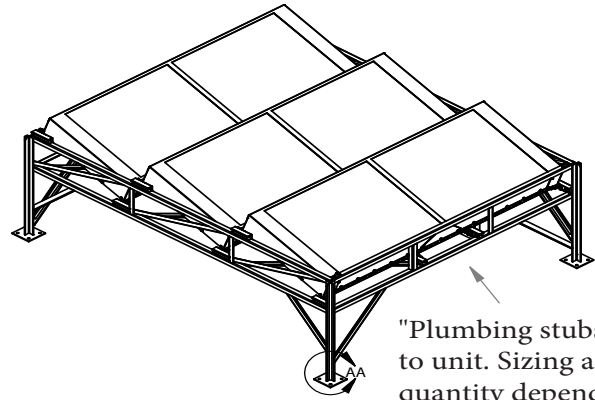

"Plumbing stubs to go to unit. Sizing and quantity depend upon the type of circuit selected."

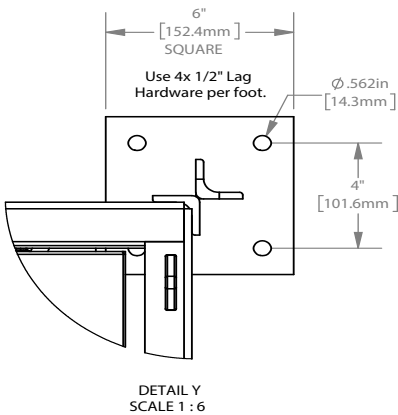
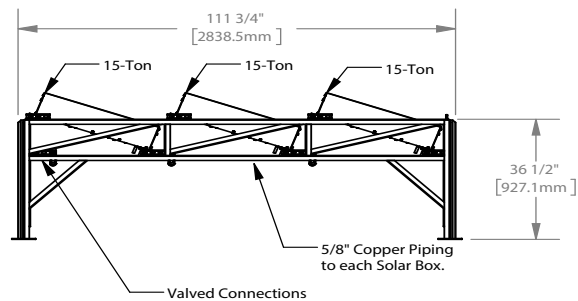
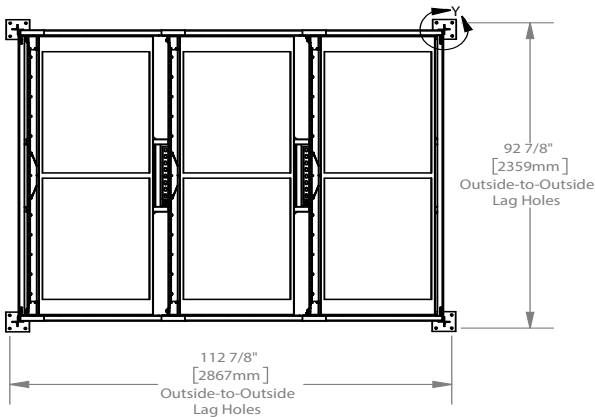
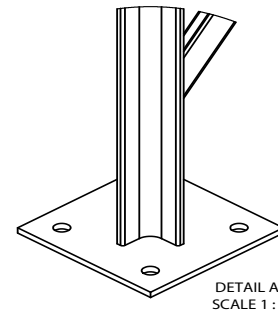
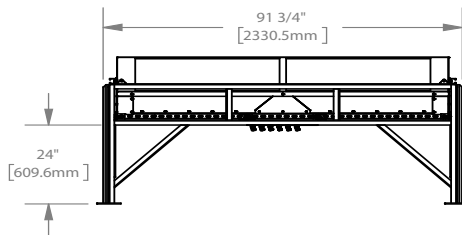

- Solar HVAC Mounting Racks allow mounting of Solar Boxes, in a sunny location, on any HVAC Unit over 30-Tons.
- The Solar Box(es) are sized for tonnage and number of circuits of the HVAC Unit and the paired rack is to be mounted on the roof next to the HVAC Unit. The solar boxes come at a fixed angle.
- Angle Iron mounting frame only. Solar Boxes, VFDs, ect. Are purchased as part of the complete unit kit (Reference IOM-0053). Customer must provide their own plumbing equipment and lagging hardware.

SLR-RCK-1448836-(DDDD) – 40-Ton



Certification number:
10002093:

NOTES:

1. Face solar panels south for optimal performance.
2. Total Weight = 1300 pounds (~325 lbs/corner); not including refrigerant
3. Plumbing sized for liquid line
4. Standard Split System piping requirements apply; contact factory for systems greater than 100ft.

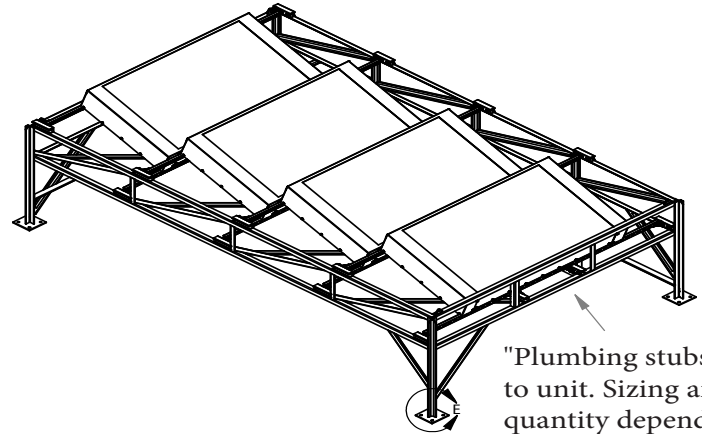

"Plumbing stubs to go to unit. Sizing and quantity depend upon the type of circuit selected."

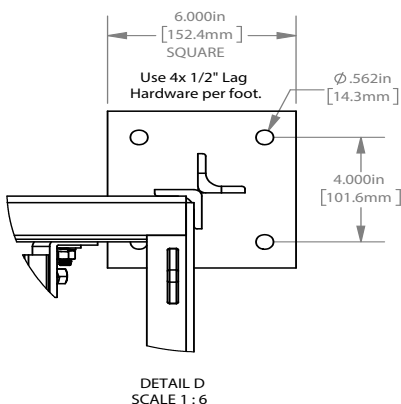
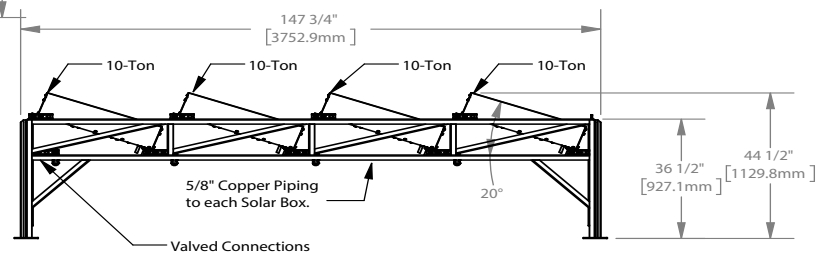
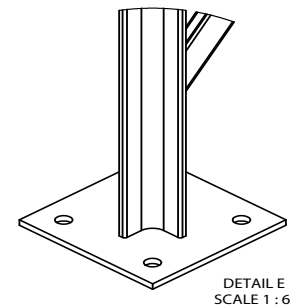
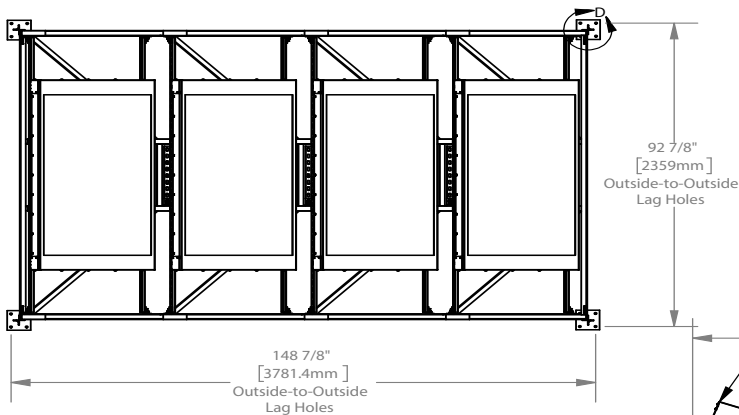
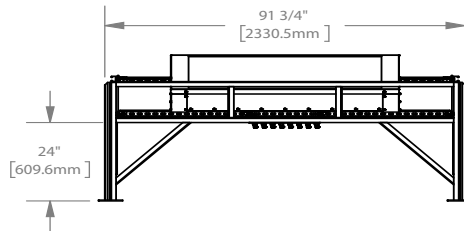

- Solar HVAC Mounting Racks allow mounting of Solar Boxes, in a sunny location, on any HVAC Unit over 30-Tons.
- The Solar Box(es) are sized for tonnage and number of circuits of the HVAC Unit and the paired rack is to be mounted on the roof next to the HVAC Unit. The solar boxes come at a fixed angle.
- Angle Iron mounting frame only. Solar Boxes, VFDs, ect. Are purchased as part of the complete unit kit (Reference IOM-0053). Customer must provide their own plumbing equipment and lagging hardware.

SLR-RCK-1448836-(DDED) – 45-Ton



Certification number:
10002093

NOTES:

1. Face solar panels south for optimal performance.
2. Total Weight = 1400 pounds (~350 lbs/corner); not including refrigerant
3. Plumbing sized for liquid line
4. Standard Split System piping requirements apply; contact factory for systems greater than 100ft.

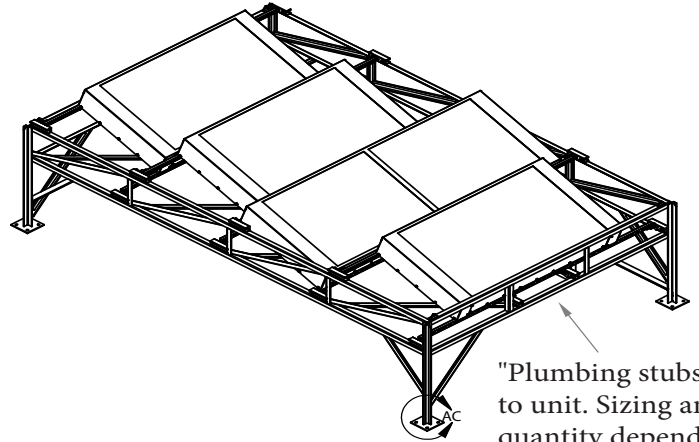

"Plumbing stubs to go to unit. Sizing and quantity depend upon the type of circuit selected."

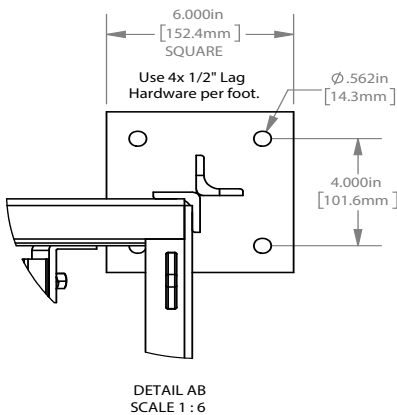
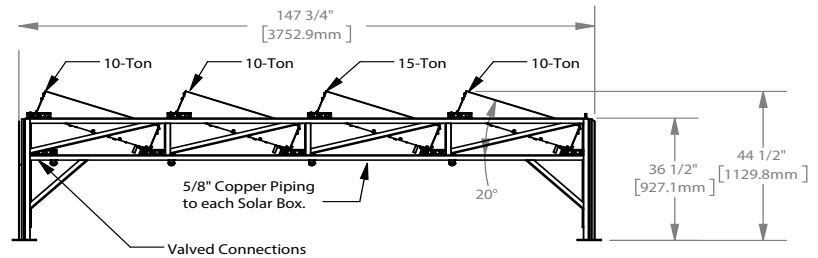
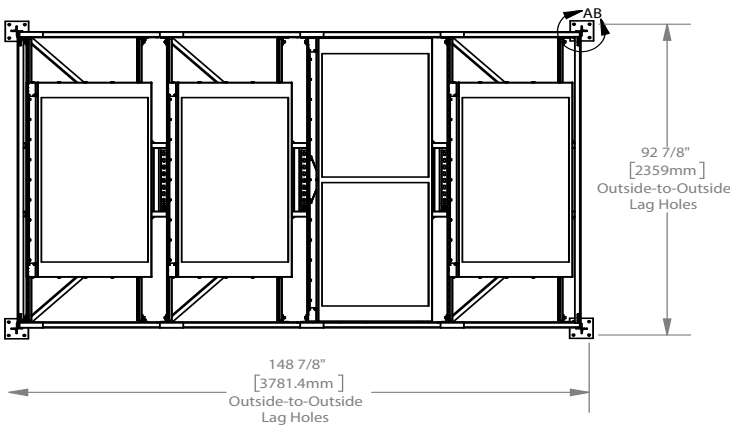
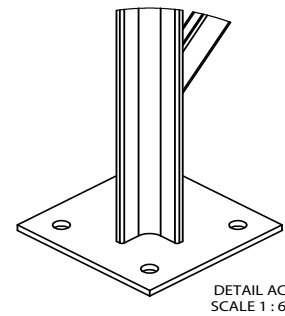
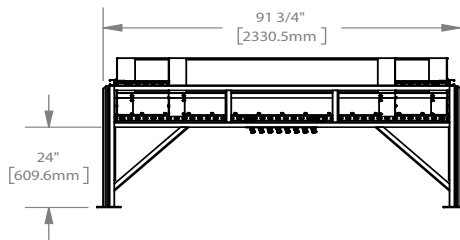

- Solar HVAC Mounting Racks allow mounting of Solar Boxes, in a sunny location, on any HVAC Unit over 30-Tons.
- The Solar Box(es) are sized for tonnage and number of circuits of the HVAC Unit and the paired rack is to be mounted on the roof next to the HVAC Unit. The solar boxes come at a fixed angle.
- Angle Iron mounting frame only. Solar Boxes, VFDs, ect. Are purchased as part of the complete unit kit (Reference IOM-0053). Customer must provide their own plumbing equipment and lagging hardware.

SLR-RCK-1448836-(DEED) – 50-Ton



Certification number:
10002093:

NOTES:

1. Face solar panels south for optimal performance.
2. Total Weight = 1400 pounds (~350 lbs/corner); not including refrigerant
3. Plumbing sized for liquid line
4. Standard Split System piping requirements apply; contact factory for systems greater than 100ft.

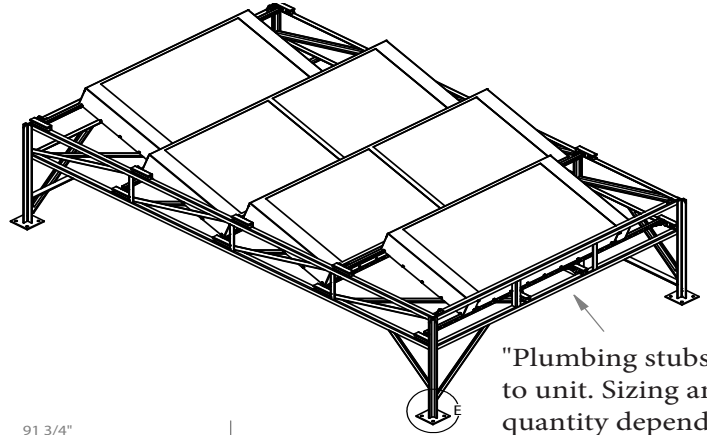

"Plumbing stubs to go to unit. Sizing and quantity depend upon the type of circuit selected."

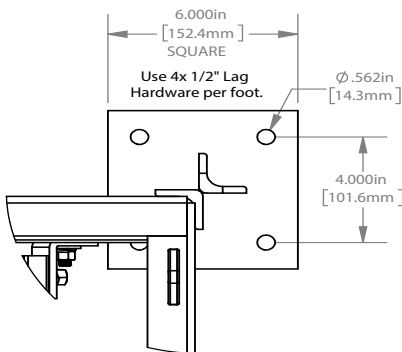
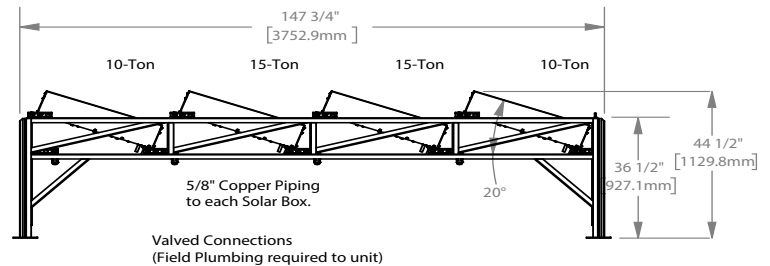
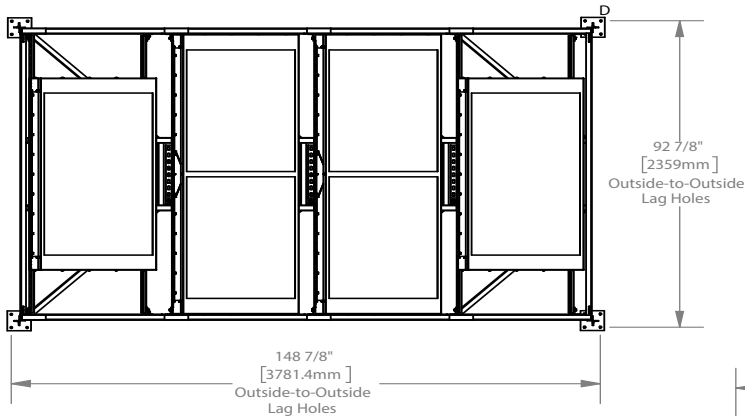
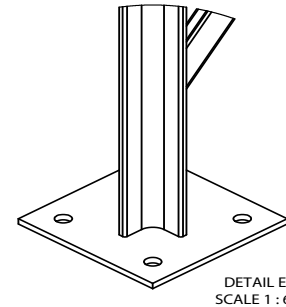
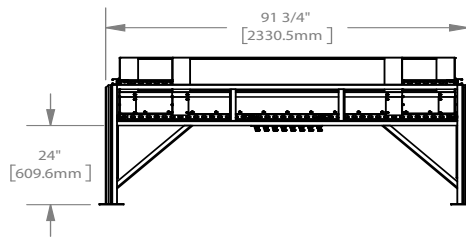

- Solar HVAC Mounting Racks allow mounting of Solar Boxes, in a sunny location, on any HVAC Unit over 30-Tons.
- The Solar Box(es) are sized for tonnage and number of circuits of the HVAC Unit and the paired rack is to be mounted on the roof next to the HVAC Unit. The solar boxes come at a fixed angle.
- Angle Iron mounting frame only. Solar Boxes, VFDs, ect. Are purchased as part of the complete unit kit (Reference IOM-0053). Customer must provide their own plumbing equipment and lagging hardware.

SLR-RCK-1448836-(DEEE) – 55-Ton



Certification number:
10002093:

NOTES:

1. Face solar panels south for optimal performance.
2. Total Weight = 1400 pounds (~350 lbs/corner); not including refrigerant
3. Plumbing sized for liquid line
4. Standard Split System piping requirements apply; contact factory for systems greater than 100ft.

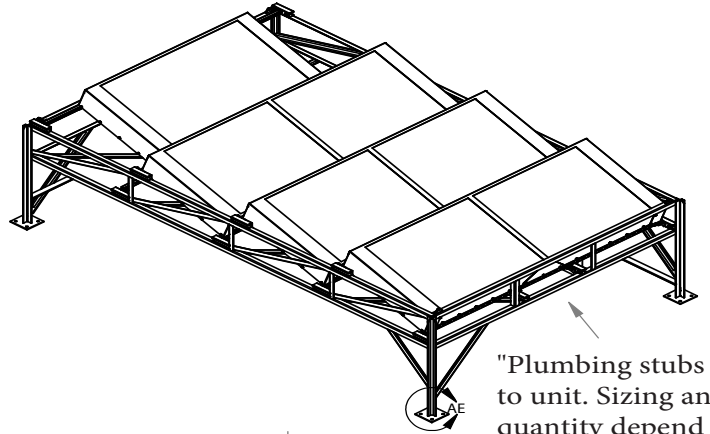

"Plumbing stubs to go to unit. Sizing and quantity depend upon the type of circuit selected."

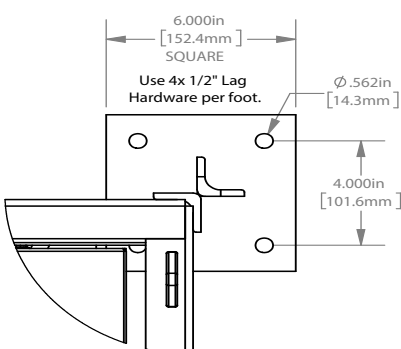
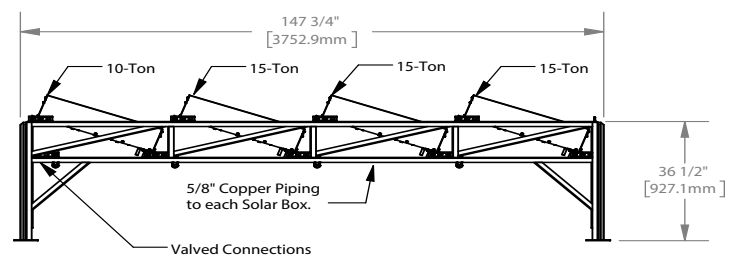
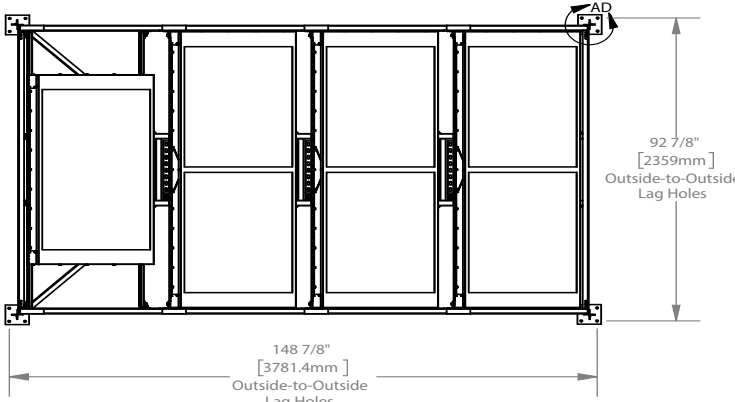
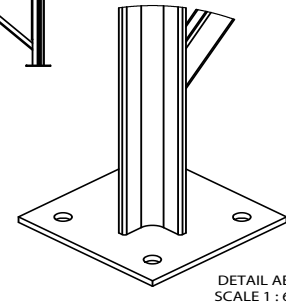
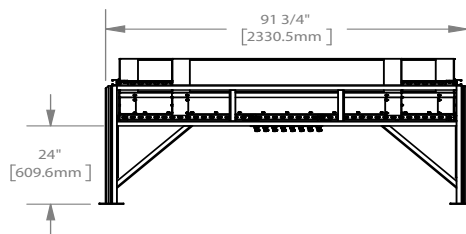

DETAIL AD
SCALE 1 : 6

- Solar HVAC Mounting Racks allow mounting of Solar Boxes, in a sunny location, on any HVAC Unit over 30-Tons.
- The Solar Box(es) are sized for tonnage and number of circuits of the HVAC Unit and the paired rack is to be mounted on the roof next to the HVAC Unit. The solar boxes come at a fixed angle.
- Angle Iron mounting frame only. Solar Boxes, VFDs, ect. Are purchased as part of the complete unit kit (Reference IOM-0053). Customer must provide their own plumbing equipment and lagging hardware.

SLR-RCK-1448836-(EEEE) – 60-Ton



Certification number:
10002093

NOTES:

1. Face solar panels south for optimal performance.
2. Total Weight = 1700 pounds (~450 lbs/corner); not including refrigerant
3. Plumbing sized for liquid line
4. Standard Split System piping requirements apply; contact factory for systems greater than 100ft.

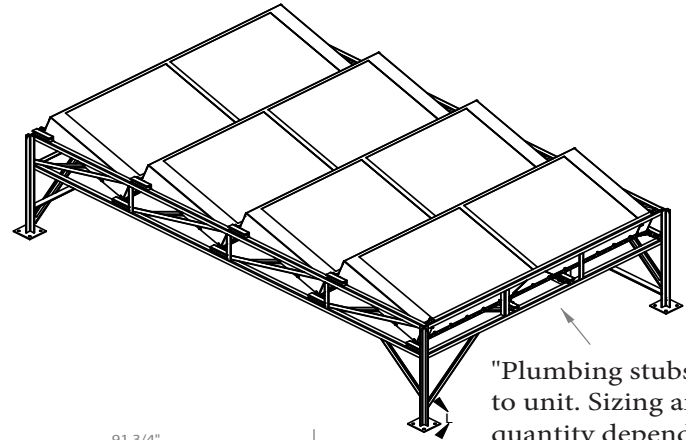

"Plumbing stubs to go to unit. Sizing and quantity depend upon the type of circuit selected."

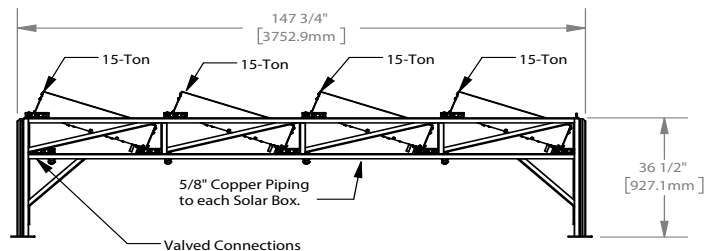
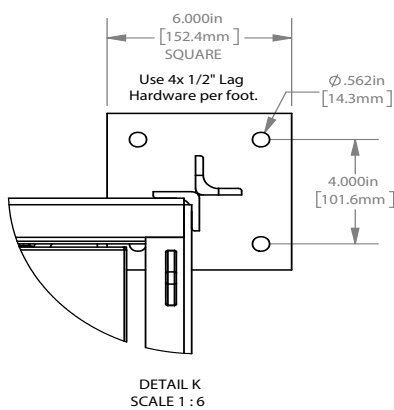
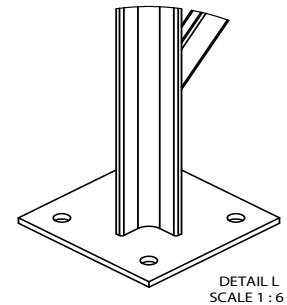
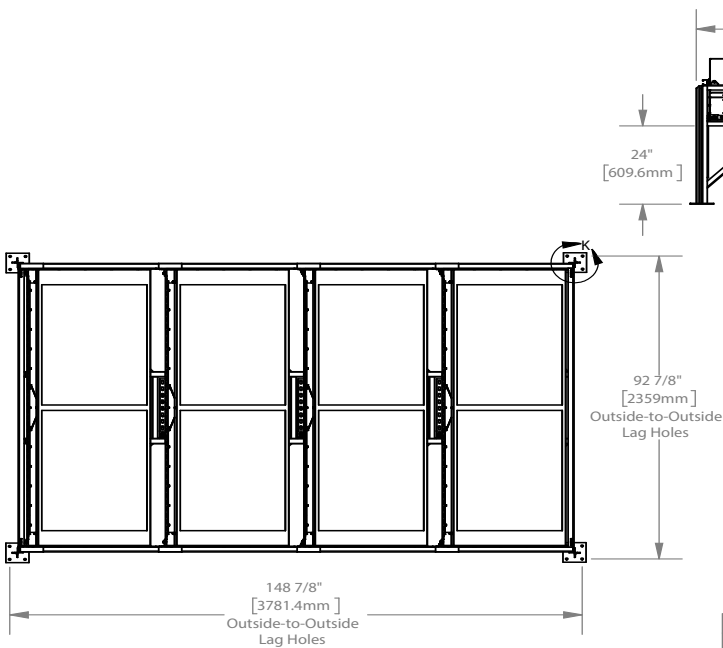

- Solar HVAC Mounting Racks allow mounting of Solar Boxes, in a sunny location, on any HVAC Unit over 30-Tons.
- The Solar Box(es) are sized for tonnage and number of circuits of the HVAC Unit and the paired rack is to be mounted on the roof next to the HVAC Unit. The solar boxes come at a fixed angle.
- Angle Iron mounting frame only. Solar Boxes, VFDs, ect. Are purchased as part of the complete unit kit (Reference IOM-0053). Customer must provide their own plumbing equipment and lagging hardware.

Appendix 1 - R410A Refrigerant Add

R410A Refrigerant to add for Solar HVAC				1.64 oz/ft		0.06 oz/ft	
Part Number	Description	Box Piping* (ft)	Unit Piping* (ft)	Fluid Add (liquid)		Fluid Add (gas)	
				(oz)	(lbs)	(oz)	(lbs)
Residential (Mini Split) Units							
SLR-BX-02C15.50	1.25-Ton Solar Box	20	4	39.4	2.5	1.4	0.1
SLR-BX-02C31.50	2.5-Ton Solar Box	30	6	59.0	3.7	2.2	0.1
Residential Units							
SLR-BX-03C31.50	3.75-Ton Solar Box	32.5	8	66.4	4.2	2.4	0.2
SLR-BX-04C31.50	5-Ton Solar Box	40	8	78.7	4.9	2.9	0.2
Commerical Units							
SLR-BX-03C31.50	3.75-Ton Solar Box	32.5	20	86.1	5.4	3.2	0.2
SLR-BX-04C31.50	5-Ton Solar Box	40	25	106.6	6.7	3.9	0.2
SLR-BX-05C37.50	7.5-Ton Solar Box	55	30	139.4	8.7	5.1	0.3
SLR-BX-05C50.00	10-Ton Solar Box	72	35	175.5	11.0	6.4	0.4
SLR-BX-05C75.00	15-Ton Solar Box	105	40	237.8	14.9	8.7	0.5

Note - This amount of refrigerant is for an average placement of the solar box using 5/8" OD copper piping.

Appendix 2

Solar Box Design Parameters

Description	Item	Unit	Item	Unit
Maximum Operating Pressure	500	PSI	3500	kPA
Operating Flow Rate Range	485	lb/hr	220	kg/h
Freeze Tolerance Limit	-22	Deg F	0	Deg C
Minimum Operating Temperature	-10	Deg F	-23	Deg C
Maximum Operating Temperature	134	Deg F	57	Deg C
Standard Stagnation Temperature	230	Deg F	110	Deg C

Liquid Line Specifications

	Liquid Line		
Unit	Velocity	Pressure Drop	Mass Flow
3.5-Ton Unit	177 FPM	4.29 lbs	589 lbs/hr
4-Ton Unit	202 FPM	5.49 lbs	673 lbs/hr
5-Ton Unit	253 FPM	8.3 lbs	841 lbs/hr