



TrueVAV

**DAT/PROCESS/SPACE
Control O/M manual**

Table of Contents

PART NUMBER AND DESCRIPTIONS.....	3-5
START UP REQUIREMENTS.....	6
REFRIGERANT PIPING GUIDELINES	7
CONTROLS DESCRIPTIONS / SAFETY / START-UP.....	8-9
PRELIMINARY TROUBLESHOOTING	10
SEQUENCE OF OPERATIONS.....	11
WIRING AND ELECTRICAL.....	12
CONTROLLER NAVIGATION	13-20
BACNET WIRING DIAGRAM.....	21
BACNET POINTS LIST	22-23
RESIDENTIAL TROUBLESHOOTING	24-40
INSTALLER NOTES	42

SEE IOM-0035 O/M APPENDICES MANUAL FOR MORE INFORMATION ON INSTALLATION AND SET UP OF PERIPHERAL DEVICES

Reference IOM-0006 for more information on Economizer & Powered Exhaust

Reference IOM-0008 For more information on Air Flow Hood

Reference IOM-0011 For more information on Mod Gas Heat

Reference IOM-0012 For more information on Mod Electric Heat

Reference IOM-0015 For more information on Extra High Static Fan

Reference IOM-0018 For more information on Super High Heat Box

Reference IOM-0025 For more information on Mated ERV

Reference IOM-0053 For more information on Solar HVAC

*** ALL REFERENCE IOM'S AVAILABLE UPON REQUEST ***

Contact iAIRE At:

www.myiaire.com

Email: sales@myiaire.com

Phone: 844-348-9168



TrueVAV Part Numbering Scheme

Commercial Package / Splits

12C - 3 4 5 6 7 8 9 10 11 12 13 - 14

Type (1,2)

VD - Cooling Only
 VG - with Gas Heat
 VH - DX Cool w/H.W. Coils
 VP - with Heat Pump

Fan (4)

L - Low/Std. Static
 M - Med. Static
 H - High Static
 E - Extra High Static

Voltage (5)

G - 230 VAC 1φ
 H - 230VAC 3φ
 K - 460VAC 3φ
 L - 575VAC 3φ

Control (6)

A - DAT w/ VAV Duct

Electric & Gas Heat (7,8,9)

XXX - Electric (kW)
 XXX - Gas (mBH)

Heat Stages (10)

A - No Controls
 B - 1 Stage
 C - 2 Stage
 D - 3 Stage
 E - 4 Stage
 M - Modulating

Roof Top Units (3)

FC04	FE04	GC04
FC05	FE05	GC05
FC06	FE06	GC06
FC07	FE07	GE04
FC08	FE08	GE05
FC09	FE09	GE06
FC12	FE12	
FC14	FE14	
FC16	FE16	
FC20	FE20	
FC24	FE24	
FC28	FE28	
FC30	FE30	

Comm. Split (3)

COOLING	COOLING	HEAT PUMP
AZ07RF07*	AP25RA30**	AQ07RFQ07*
AZ08RF08*	AP27RA30**	AQ08RFQ08*
AZ12RF12*	AP30RA30**	AQ12RFQ12*
AZ14RF14*	AP4039M**	AQ16RFQ16**
AD12RF12**	AP5039M**	AQ25RQ25**
AD14RF14**	AP6039M**	
AD16RF16**	AP6539M*	
AD25RA25**	AP7039M**	
AD28RA28**	AP8039M**	
	AP9039M**	
	AP10039M**	

*one circuit
 **two circuit

Res. Split (3)

COOLING	HEAT PUMP
Z24FT3	Z24FT3
Z36FT3	Z36FT3
Z48FT6	Z48FT6
Z60FT6	Z60FT6
Z24Z36	Z24Z36
Z36Z36	Z36Z36
Z48Z60	Z48Z60
Z60Z60	Z60Z60

Options (14)

0 - No Options
 A - Ionization
 B - Whole Unit (UG)
 C - All Coils (UG)
 D - Condenser Coil (UG)
 E - ERV (See options pg.2)
 F - MERV 13 2" Filter
 G - 2 Pos. OA Damper
 H - BACNet
 J - Hinged Access Doors
 K - DW w/ Poly Insulation
 L - SS Drip Pan
 M - SS Gas Heat Exchanger
 N - Dirty Filter Switch
 P - Service Outlet (non-pwr)
 Q - Service Outlet (pwr)
 R - Split Power Fuse Disc.
 S - Split Power Switch Disc.
 T - Smoke SA
 U - Smoke RA
 V - Low Ambient Bypass
 W - Economizer
 X - Intertwined Evap. Coil
 Y - Start Up
 1 - 365 Day Annual Timer
 2 - SOLAR HVAC
 3 - Condensate Flow Switch
 4 - Airflow Monitoring
 5 - Hail Guard
 6 - Fixed Powered Exhaust
 7 - Phase Monitor
 8 - Modulating Powered Exhaust
 9 - Crate

Disconnect (11,12)

00 - No Disconnect
 01 - 240V - 30A Fuse
 02 - 240V - 60A Fuse
 03 - 240V - 100A Fuse
 04 - 240V - 150A Fuse
 05 - 240V - 200A Fuse
 06 - 240V - 300A Fuse
 11 - 240V - 30A Switch
 12 - 240V - 60A Switch
 13 - 240V - 100A Switch
 14 - 240V - 150A Switch
 15 - 240V - 200A Switch
 16 - 240V - 300A Switch
 21 - 600V - 30A Fuse
 22 - 600V - 60A Fuse
 23 - 600V - 100A Fuse
 24 - 600V - 150A Fuse
 31 - 600V - 30A Switch
 32 - 600V - 60A Switch
 33 - 600V - 100A Switch
 34 - 600V - 150A Switch

Configuration (13)

A - Down Supply / Down Return
 B - Horizontal Supply / Down Return
 C - Down Supply / Horizontal Return
 D - Horizontal Supply / Horizontal Return



ERV Options (if ERV selected on page 1)

- 15 16 17 18**Wheel Diameter (15,16)**

19 - 19"
25 - 25"
30 - 30"
36 - 36"
41 - 41"
46 - 46"
52 - 52"
58 - 58"
64 - 64"

Airflow Capability (17)

L - Low
H - High

Options (18)

0 - No Options
A - 2 Position Outside Air Damper
B - 2 Position Exhaust Air
C - Building Pressure
D - Outside Airflow Monitoring
H - Supply Air Filter Status
J - Exhaust Air Filter Status
K - Supply Air Blower Status
L - Exhaust Air Blower Status
M - With OA Blower
N - Sensible Wheel
P - Frost Protection

TRUE VAV NUMBERING SCHEME INSTRUCTIONS

How to Translate TRUE VAV Part Numbering Schemes

True VAV's part numbering scheme is composed of similar product identification, when compared to Carrier, in order to easily provide common options and features. By referencing the 2 character "type" in the beginning of each part number, it is easy to distinguish cooling only, gas heat, or heat pump models. A full list of Carrier unit model numbers is provided from by following the link in the web addresses listed below. Using the comparison below, an excerpt is provided from Carrier's technical guide to illustrate how a common unit can be traced from TRUE VAV to Carrier.

Asterisk

All part numbers and part number references will use an asterisk, *, to designate all characters which do not apply to the part number for the information being provided in that section. Where an asterisk appears in the middle of a part number, the missing characters are irrelevant to the information being provided. Where the asterisk appears at the end of a part number, the remaining part number characters are irrelevant to the information being provided.

To determine the specific Carrier unit you need, see below for how to determine which Carrier manual you will need.

For more information about Carrier Commercial Split Units go to: <http://www.carrier.com/building-solutions/en/us/products/split-systems/split-systems/>

For more information about Carrier Commercial Units go to: <http://www.carrier.com/building-solutions/en/us/products/packaged-outdoor/outdoor-packaged-units/>

For more information about Carrier Residential Units go to: <http://www.carrier.com/homecomfort/en/us/products/heating-and-cooling/packaged-products/>

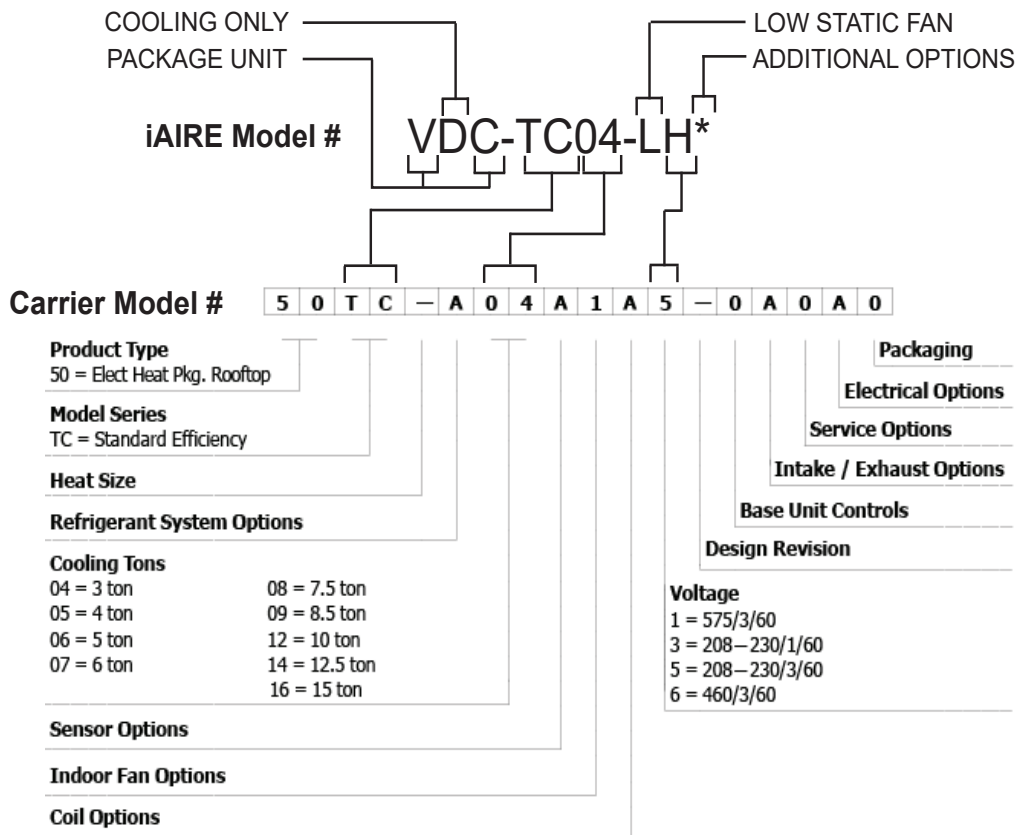

START-UP REQUIREMENTS ! IMPORTANT !

To maintain factory warranty, all units must have an authorized factory start-up and the start-up paperwork on file.

For Questions, Contact iAIRE At:

www.myiaire.com

Email: sales@myiaire.com

Phone: 844-257-0991

Fill out the Start-Up request form here:

<https://www.myiaire.com/support-service/service-request/>

REFRIGERANT PIPING GUIDELINES

IMPORTANT: The information below is intended for general information on refrigerant piping only. Reference specific AHU and condensing units manuals for specific piping details.

The design of a refrigerant piping system should:

Ensure proper refrigerant feed to evaporators; Provide practical refrigerant line sizes without excessive pressure drop; Prevent excessive amounts of lubricating oil from being trapped in any part of the system; Protect the compressor at all times from loss of lubricating oil; Prevent liquid refrigerant or oil slugs from entering the compressor during operating and idle time; and Maintain a clean and dry system.

REFRIGERANT LINE VELOCITIES

Economics, pressure drop, noise, and oil entrapment establish feasible design velocities in refrigerant lines. These are:

Suction line - 700 to 4,000 fpm

Discharge line - 500 to 3,500 fpm

Condenser drain line - 100 fpm or less

Liquid line - 125 to 450 fpm

Minimum Discharge- Line Velocities		
Refrigerant Velocity, fpm		
Nominal Pipe Size, in.	Riser	Horizontal
7/8	375	285
1-1/8	430	325
1-3/8	480	360
1-5/8	520	390
2-1/8	600	450

Higher gas velocities are sometimes found in relatively short suction lines on comfort air conditioning or other applications where the operating time is only 2,000 to 4,000 hrs per year and where the low initial cost of the system may be more significant than low operating cost.

Industrial or commercial refrigeration applications, where equipment runs almost continuously, should be designed with low refrigerant velocities for the most efficient compressor performance and low equipment operating cost.

The liquid line from the condenser to the receivers should be sized for 100 fpm or less to ensure positive gravity flow without incurring a backup of liquid flow. Liquid lines from the receivers to the evaporator should be sized to maintain velocities below 300 fpm, thus minimizing or preventing liquid hammer when solenoids or other electrically operated valves are used.

LINE SIZING

In sizing refrigerant lines, cost considerations favor keeping the line size as small as possible. However, suction and discharge line pressure drops cause loss of compressor capacity and increased power usage.

Excessive liquid line pressure drops can cause the liquid refrigerant to flash, resulting in faulty expansion valve operation. Refrigeration systems are designed so that friction pressure losses do not exceed a pressure differential equivalent to a corresponding change in the saturation boiling temperature.

The primary measure for determining pressure drop is a change in saturation temperature. Pressure drop in a refrigerant line causes a reduction in system efficiency. Correct sizing must be based on minimizing cost and maximizing efficiency.

Pressure drop calculations are determined as normal pressure loss associated with a change in saturation temperature of the refrigerant. Typically, the refrigeration system will be sized for pressure losses of 2°F differential or less for each segment of the discharge, suction, and liquid lines. An HFC refrigerant liquid line is sized for pressure losses of 1° differential or less.

IMPORTANT: The information above is intended for general information on refrigerant piping only. Reference specific AHU and condensing units manuals for specific piping details.

CONTROLS DESCRIPTIONS

DAT CONTROL

Designed to temper the air supplied to other HVAC equipment by supplying neutral air.

PROCESS / ERV SPACE CONTROL

Designed to condition the air to provide cooling or heating to the building space so only (1) piece of equipment is needed to both treat outside air and maintain space temperatures.

GENERAL INSTRUCTIONS

An iAIRE's operation is a function of the options and control packages that the iAIRE unit is equipped with.

Confirm that all unit clearances shown on the submittal are present around the unit. If the installation is on a roof with a parapet wall, make sure there is enough air flow through the condensing coil to not impact operations.

RECEIVING / INSPECTION

Check part # of iAIRE unit to ensure it is what was ordered.

Verify voltage/phases match.

At the time of delivery the iAIRE unit should be visually inspected for possible damage. If any damage is found it should be reported immediately to the last courier company, preferably in writing.

RIGGING

Utilize the Carrier factory information on rigging these units. If you need help accessing this information, please contact iAIRE customer service at: sales@myiaire.com or 844-348-9168. **Refer to**

DAT & EAT SENSOR INSTRUCTIONS

On iAIRE's Split Systems, the DAT & EAT sensors are not pre-installed in the unit. Both the DAT & EAT sensors need to be installed in the duct work.

Once the unit is installed, the EAT sensor should be placed in the outside air duct and in the outside air stream as shown in the diagram.

Once the unit (and heater if applicable) is installed, iAIRE, LLC

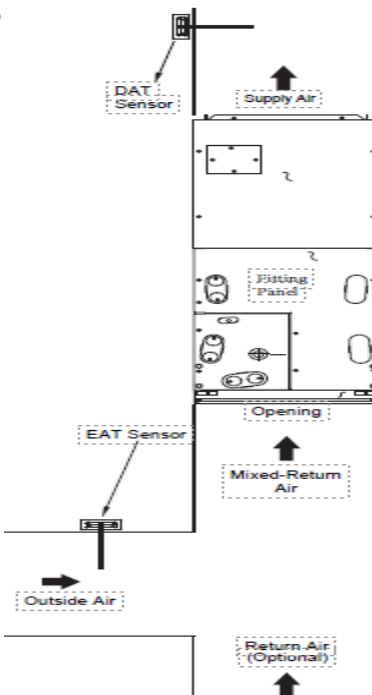

the DAT sensor should be placed at least 3-ft downstream of the discharge of the unit (and heater if applicable) as shown in the diagram.

NOTE: Sensors and Wire Bundles are found on top of the unit.

SAFETY CONSIDERATIONS

Installation and servicing of the iAIRE units can be hazardous due to system, pressure, electrical components and moving parts. Only trained and qualified service personnel should install, repair or service these units.

When working on iAIRE or other HVAC units, observe precautions in the literature, tags and labels attached to the units, and any other safety precautions that may apply.

Follow all local, national and industry electrical codes when installing these units and accessories.

START-UP

PROCESS / DISCHARGE AIR TEMP CONTROL PACKAGE START-UP

Physical Inspection (pre power-up)

Check part # of iAIRE unit to ensure it is what was ordered.

Verify voltage/phases match.

1. Verify condition of unit and note any installation or shipping damage to coils or cabinets.
2. Verify installation of condensate drain trap.
3. Verify power is available at disconnect and fuses are installed if required. Check incoming power to make sure it is within tolerance.
4. Verify that all airways are open. (Fire dampers and supply air registers.)
5. Check blower belt tension. (if available)
6. Confirm that the space sensor is installed. (Space Control units only, see wiring in figure "B" on installatoin wiring diagram pages. Space Sensors must be wired using shielded wire.

After power-up

1. Check incoming 3-phase power for a stinger leg if voltage is 208/230VAC. If so ensure that stinger leg (high voltage phase to ground) is the center leg.
2. Go to iAIRE controller and set both the heat and cool CFM. The heat CFM is the VFD % in the heat mode that the AHU fan will run. The cool CFM is the VFD % the AHU fan will run in all other modes.

3. Remove panel from outside air section and verify outside air damper is fully open. Set adjustment thumbwheel on damper motor for full opening. Check crank arms and balljoints on damper mechanism allow damper to open fully.

Charging

1. Ensure Compressor VFD is running at 60Hz.
2. Disconnect 2-pin signal plug from Sporlan IB circuit board. This will close the modulating hot gas valve to allow correct charging.
3. Invert refrigerant jug to provide liquid charge into suction line and proceed to charge unit for 10 degrees of subcooling and 20 degrees superheat. Depending on ambient conditions, evaporator leaving air temperature should be between 48-58 °F.
4. When charge is complete return signal connector to Sporlan IB board and let Compressor VFD run normal.
5. Disconnect jumper from terminal strip input to allow the iAIRE controller to take over machine.
6. Adjust sensor setpoint to a low setpoint to bring all cooling stages on and check if hot gas line warms up.

TEST PROCEDURE

Verify operation as described above by monitoring liquid line temperature and observing motor speed.

Heater check

1. Verify Kw of installed electric heaters.
2. Disconnect white space temperature sensor wire from terminal strip. (This will make the iAIRE controller see a space temperature of -40 degrees and start heaters) There is a five minute delay at start of heat cycle. With heater running check amperage and verify discharge air temperature.
3. Return white space temperature sensor wire to terminal strip.

Checking and adjusting system refrigerant charge.

Before connecting gauges to the systems suction and discharge service ports, make the following adjustments.

1. Before running blower and compressors, ensure Compressor VFD is running at 60Hz.
2. If Low Ambient is installed, shut off ball valve to low ambient and open bypass around low ambient to isolate L.A. valve.
3. Before running blower and compressors, put iAIRE controller in TEST mode and manually set Hot Gas Valve % to 0.0% to direct all refrigerant to DX cooling.

a) Connect gauges. (Pre-load evacuated split systems with nominal weight of refrigerant)

b) Enable FAN and then Cool Stage 1 in TEST mode and allow several minutes for system to stabilize.

c) Note, high pressure saturation Temperature on gauge and the temperature of the Liquid Line leaving the condenser. (Condensing temperature should be 100-110 degrees minimum)

d) Calculate Sub cooling (Saturation Temp – Liquid line Temp = Sub cooling)

e) Charge systems for 12-15 degrees of sub cooling. Add refrigerant if sub cooling is low and remove if high. With all cooling stages enabled system should deliver 55 degree air, or less depending on ambient conditions.

f) Record sub cooling temperature _____ degrees

g) With controller still in TEST mode, increase the Hot gas valve position in increments until discharge air, (DAT) is raised to 70 - 72 degrees.

h) Record sub cooling temperature _____ Record evap saturation temperature _____

i) Let Compressor VFD run normal.

j) If Low Ambient is installed, open valve to low ambient and close valve to bypass Low Ambient.

k) Record sub cooling temperature _____ Record evap saturation temperature _____

l) Note: You can leave the TEST menu and enter the STATUS menu to check system temperatures at any time. TEST mode will remain active until it is manually disabled.

m) When charging and checks are complete, disable the TEST mode and let Compressor VFD run normal.

n) Allow system to stabilize and check sub cooling again.

o) Add/Remove refrigerant as necessary to maintain about 4 degree of sub cooling.

p) Remove gauges and replace service port covers.

q) If charging for the first time note all required conditions in startup sheets and record weight of all refrigerant added.

Record Keeping

1. Record all readings and conditions in startup sheets and add notes to call attention to any issues for the unit installing contractor to attend to.

2. Have the startup documents signed by supervising foreman for mechanical contractor.

MODULATING GAS SETUP:

- 1: SEE IOM-0035 for standard carrier heat
- 2: SEE IOM-0035 for High Heat Box.

PRELIMINARY TROUBLESHOOTING

1. The unit does not come on.
 - a. Check to make sure there is power to the unit.
 - b. Check to make sure the disconnect is on.
 - c. Check to make sure the jumper between pins on terminal strip 1 is removed.
 - i. If other wires are attached to pins, make sure there is not a short or the unit will not turn on. This is the location for remote start/stop.
 - d. Check to make sure the circuit breaker or the 24V power supply is not tripped.
2. Fan speed is not correct.
 - a. Go to the iAIRE controller and adjust the fan speed up or down as required.
3. The unit is tripping out on high heat and requires a manual reset.

The air speed needs to be raised to prevent the heat from being too hot in the unit.

SEQUENCE OF OPERATIONS

DAT

In the UNOCCUPIED mode, the outside air unit will be off and the outside air damper, if supplied, will be closed. Occupied or Unoccupied is signaled to the IAIRE controller via a normally open or normally closed contact on the OCCUPIED input with a clock or switch. An open contact on the input indicates OCCUPIED, a closed contact indicates UNOCCUPIED.

In the OCCUPIED mode, the outside air damper will open and the supply fan will ramp up to the configured fan speed (dependent on whether the unit is heating or cooling). The Fan input is monitored to determine if fan is operating or not. If not operating, the IAIRE controller will enter into an alarm state, start staging off compressors, and attempt to cycle the fan until it starts.

There is a configurable EAT Heat Lockout (default 58F). If the entering air temperature (EAT) is $<$ or $=$ to the lockout, then the heat stages will cycle to maintain the discharge air temperature DAT setpoint.

There is a configurable EAT Cool Lockout (default 61F). If the EAT is $>$ or $=$ to this lockout than Y1 is always on and Y2-Y4 is staged on depending on demand (if enabled), along with the modulated hot gas valve will be used to maintain the DAT.

If the EAT is $>$ the EAT Heat Lockout (default 58F) and $<$ the EAT Cool Lockout (default 61F), Y1 will stage on and the modulated hot gas will maintain DAT unless DAT setpoint = EAT then free-cooling will engage and Y1 will be off. While in this mode, if discharge humidity is $>$ 50% then Y1 will stage on and if its $>$ 70% then Y2 will stage on as well.

SEQUENCE OF OPERATIONS NOTES

All forms of temperature control (PROCESS / ERV SPACE / DAT) can come with the ability to control the supply fan with VAV control.

VAV control can be set up for either duct static pressure control or building pressure control. In either of these cases, there is a min CFM setting to maintain minimum airflow to keep the evaporator coil from freezing and a max CFM setting to make sure you cannot run more air than the unit can heat or cool.

Duct static control tries to maintain a user set constant pressure in the discharge duct of the equipment.

Building static control tries to maintain a user set constant pressure in the building space.

PROCESS / ERV SPACE

In the UNOCCUPIED mode, the outside air unit will be off and the outside air damper, if supplied, will be closed. Occupied or Unoccupied is signaled to the IAIRE controller via a normally open or normally closed contact on the OCCUPIED input with a clock or switch. An open contact on the input indicates OCCUPIED, a closed contact indicates UNOCCUPIED.

In the OCCUPIED mode, the outside air damper will open and the supply fan will start. When equipped with a Variable-Frequency Drive (VFD), the fan will ramp up to the configured fan speed (dependent on whether the unit is heating or cooling). The Fan input is monitored to determine if fan is operating or not. If not operating, the IAIRE controller will enter into an alarm state, start staging off compressors, and attempt to cycle the fan until it starts.

There is a configurable EAT Heat Lockout (default 58F). If the EAT is $<$ or $=$ to this temperature, the electric heat stages will cycle to maintain the room air temperature setpoint.

There is a configurable EAT Cool Lockout (default 61F). If the EAT is $>$ or $=$ to this temperature than Y1 is always on and Y2-Y4 (if enabled) along with the modulated hot gas valve will be used to maintain the room air temperature.

If the EAT is $>$ the EAT Heat Lockout (default 58F) and $<$ the EAT Cool Lockout (default 61F) The modulated hot gas valve is used to maintain room air temperature (Y1 will turn on as necessary). While in this mode, if humidity is $>$ 50% then Y1 will stage on and if humidity is $>$ 70% then Y2 will stage on as well. Y2 will stage off, once on, if necessary to help maintain room air temperature.

WIRING AND ELECTRICAL

DAT default variables

EAT cool lockout	(61 degrees)
EAT heat lockout	(58 degrees)
DAT setpoint	(70 degrees)
EAT cool 2 lockout	(72 degrees)
LAT setpoint	(55 degrees) DX
EAH humidity lockout	(55% RH)

Process default variables

EAT cool lockout	(61 degrees)
Room setpoint	(60-80 degrees)
EAT cool 2 lockout	(72 degrees)
EAH humidity lockout	(55% RH)

NAVIGATING ON AN iAIRE CONTROLLER

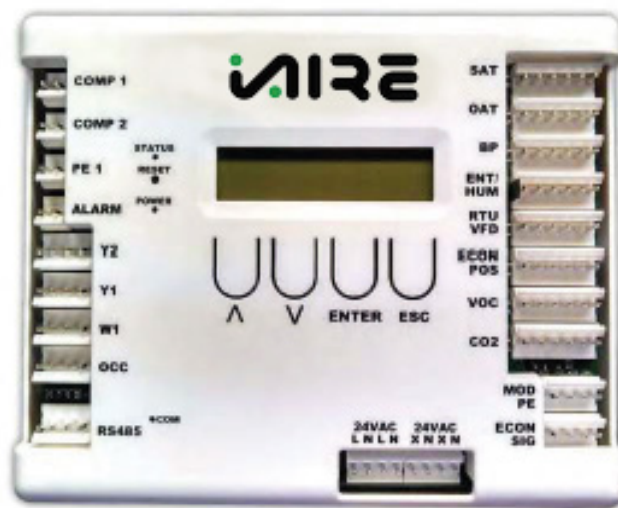
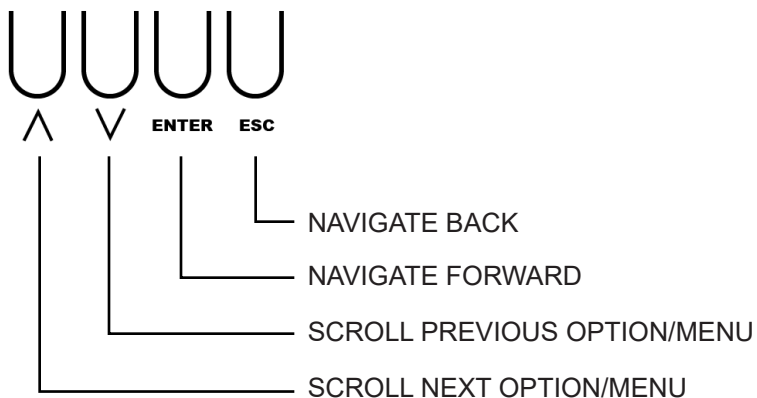

POWER ON THE CONTROLLER AND THE FIRST MENU IS **STATUS MENU**. TO NAVIGATE THROUGH THE OPTIONS, PRESS THE **UP ARROW** KEY. PRESS **ENTER** TO MAKE CHANGES IN ANY SUB MENU. TO GO BACK TO THE MAIN STATUS MENU, PRESS THE **ESC** BUTTON.

MENU SCREENS BEGIN ON THE FOLLOWING PAGE.

CONTROLLER NAVIGATION

STATUS MENU

FAN STATUS

RANGE:

On/Off

NOTE: Supply Fan Status.

STARTUP STATUS

RANGE:

Started_Off

NOTE: Controller is enabled or disabled.

RANGE:

On/Off

NOTE: BAS Switch.

RANGE:

On/Off

NOTE: Test Mode.

ENTERING AIR TEMP STATUS

RANGE:

- 058 F_132 F

NOTE: View Entering (OA) Air Temp. Sensor failures register as -58F.

ROOM AIR HUMIDITY STATUS

RANGE:

000_100

NOTE: View Room Humidity %.

ROOM SP AND TEMP STATUS

RANGE:

032 F_085 F

NOTE: View Room Temp Setpoint and Actual Temp.

DAT/LAT STATUS

RANGE:

- 058 F_132 F

NOTE: "Discharge Air Temp. of Unit / Leaving Air Temp. of Evaporator Sensor failures register as -58F."

DEHUMIDIFICATION STATUS

RANGE:

Disabled/Enabled

NOTE: Enabled because of Dehumidification call.

COOL MODE STATUS

RANGE:

Disabled/Enabled

NOTE: Enabled because of Cooling call.

HOT GAS STATUS

RANGE:

000_100

NOTE: View % of Modulating Hot Gas Reheat.

HEATING STAGES STATUS

RANGE:

W1 W2 W3

NOTE: View Number of Heating Stages called.

COOLING STAGES STATUS

RANGE:

Y1 Y2 Y3 Y4

NOTE: View Number of Cooling Stages called.

COMPRESSOR STATUS

COMP. STATUS/(Heat):

10.00V d 033F 00

COMP. STATUS/(Cool):

10.00V L033F 00

COMP. Disabled:

00.00V

VAV STATUS MENU

(VAV Mode Only)

DUCT PRESSURE

DEFAULT:

[enabled]

NOTE: Duct pressure 00.00 IN H2O. Fan speed (FAST) 100.

BUILDING PRESSURE

DEFAULT:

[enabled]

NOTE: Building pressure -00.50 IN H2O. Fan speed (FAST) 100.

TEST MODE MENU

HOT GAS TEST

RANGE: 0_100% **DEFAULT:** 000

NOTE: Allows test of modulating gas reheat valves. Must have Cool 1 Test stage enable to create any reheat.

COMPR. VFD SPEED TEST

RANGE: 0_100% **DEFAULT:** 100%

COOL 1 TEST

RANGE: Enabled/Disabled **DEFAULT:** N/A

NOTE: Turns on relay to turn Compressor 1 on.

FAN TEST

RANGE: Enabled/Disabled **DEFAULT:** N/A

NOTE: Turns on supply fan contactor. Fan runs at VFD Speed Test %.

HEAT 1 TEST

RANGE: Enabled/Disabled **DEFAULT:** N/A

NOTE: Turns on relay to turn W1 on.

HEAT 2 TEST

RANGE: Enabled/Disabled **DEFAULT:** N/A

NOTE: Turns on relay to turn W2 on.

HEAT 3 TEST

RANGE: Enabled/Disabled **DEFAULT:** N/A

NOTE: Turns on relay to turn W3 on.

COOL 2 TEST

RANGE: Enabled/Disabled **DEFAULT:** N/A

NOTE: Turns on relay to turn Compressor 2 on.

COOL 3 TEST

RANGE: Enabled/Disabled **DEFAULT:** N/A

NOTE: Turns on relay to turn Compressor 3 on.

COOL 4 TEST

RANGE: Enabled/Disabled **DEFAULT:** N/A

NOTE: Turns on relay to turn Compressor 4 on.

MOD HEAT TEST

RANGE: 0_100% **DEFAULT:** 000

NOTE: Allows test of modulating gas heat valve. Must have W1 Test stages enabled to create any heat.

IDF VFD SPEED TEST

RANGE: 0_100% **DEFAULT:** 50%

OA TEST

RANGE: 0_100% **DEFAULT:** 000

NOTE: Allows test of outside air flow.
ERV Only

EA TEST

RANGE: 0_100% **DEFAULT:** 000

NOTE: Allows test of exhaust air flow.
ERV Only

ERV WHEEL TEST

RANGE: On/Off **DEFAULT:** N/A

NOTE: ERV Only

SETPOINTS MENU

VFD SPEED COOL %

RANGE: 0_100% (100% = 60 Hz) **DEFAULT:** 60%
NOTE: Supply fan speed in cooling mode.

VFD SPEED HEAT %

RANGE: 0_100% (100% = 60 Hz) **DEFAULT:** 50%
NOTE: Supply fan speed in heating mode.

EAT COOL LCKOUT

RANGE: 32F_100F **DEFAULT:** 68F

LOCKOUT DEADBAND

RANGE: 01_30 67_38F **DEFAULT:** 07 61F
NOTE: Deadband/HeatLO

HUMIDITY STAGE 1 SETPOINT %

RANGE: 0_100% **DEFAULT:** 56%

HUMIDITY STAGE 2 SETPOINT %

RANGE: 0_100% **DEFAULT:** 60%

DAT SETPOINT

RANGE: 000F_100F **DEFAULT:** 072F
NOTE: (DAT MODE ONLY)

ROOM SETPOINT

NOTE: Set via I/O. Space/Process Mode Only.

LAT SETPOINT

RANGE: 39 F_ 58 F **DEFAULT:** 55 F
NOTE: Temperature unit is trying to control leaving air temperature off of evaporator coil when LAT override is enabled.

SET DUCT PRESSURE

RANGE: 0.00 _ 2.00 IN H₂O **DEFAULT:** 1.20 IN H₂O
NOTE: (VAV Mode Only)

CONFIGURATION MENUS

CONFIG HEAT AND COOL OFFSETS

OPTION: Cool Stage 2 On Offset
RANGE: 10F Below_10F Above **DEFAULT:** On 02F above SP
 CS2 On <Setting>

NOTE: Allows user to set temp difference from setpoint that Y2 is enabled.

OPTION: Cool Stage 2 Off Offset
RANGE: 10F Below_10F Above **DEFAULT:** Off at exact SP
 CS2 Off <Setting>

NOTE: Allows user to set temp difference from setpoint that Y2 is disabled.

OPTION: Cool Stage 3 On Offset
RANGE: -10F SP to +10F SP **DEFAULT:** +3F SP

NOTE: Allows user to set temp difference from setpoint that Y3 is enabled.

OPTION: Cool Stage 3 Off Offset
RANGE: -10F SP to +10F SP **DEFAULT:** -1F SP

NOTE: Allows user to set temp difference from setpoint that Y3 is disabled.

OPTION: Cool Stage 4 On Offset
RANGE: -10F SP to +10F SP **DEFAULT:** +4F SP

NOTE: Allows user to set temp difference from setpoint that Y4 is enabled.

CONFIG HEAT AND COOL TIMERS

OPTION: Cool 1 On Delay
RANGE: 000S _ 600S **DEFAULT:** C1 On Delay
 240S (Setting)

NOTE: Allows user to set delay before Y1 comes on after controller deems Y1 is required.

OPTION: Cool 1 Off Delay
RANGE: 000S _ 600S **DEFAULT:** 060S

NOTE: Allows user to set delay before Y1 goes off after controller deems Y1 isn't required.

OPTION: Cool 2 On Delay
RANGE: 000S _ 600S **DEFAULT:** C2 On Delay
 240S (Setting)

NOTE: Allows user to set delay before Y2 comes on after controller deems Y2 is required.

OPTION: Cool 2 Off Delay
RANGE: 000S _ 600S **DEFAULT:** 060S

NOTE: Allows user to set delay before Y2 goes off after controller deems Y2 isn't required.

OPTION: Cool 3 On Delay
RANGE: 000S _ 600S **DEFAULT:** C3 On Delay
 240S (Setting)

NOTE: Allows user to set delay before Y3 comes on after controller deems Y3 is required.

OPTION: Cool Stage 4 Off Offset
RANGE: 10F Below_10F Above **DEFAULT:** On 02F above SP
 CS4 Off <Setting>

NOTE: Allows user to set temp difference from setpoint that Y4 is disabled.

OPTION: Heat Stage 1 On Offset
RANGE: -10F SP to +10F SP **DEFAULT:** 0F SP

NOTE: Allows user to set temp difference from setpoint that W1 is enabled.

OPTION: Heat Stage 1 Off Offset
RANGE: -10F SP to +10F SP **DEFAULT:** +4F SP

NOTE: Allows user to set temp difference from setpoint that W1 is disabled.

OPTION: Heat Stage 2 On Offset
RANGE: -10F SP to +10F SP **DEFAULT:** -2F SP

NOTE: Allows user to set temp difference from setpoint that W2 is enabled.

OPTION: Heat Stage 2 Off Offset
RANGE: -10F SP to +10F SP **DEFAULT:** +2F SP

NOTE: Allows user to set temp difference from setpoint that W2 is disabled.

OPTION: Heat Stage 3 On Offset
RANGE: -10F SP to +10F SP **DEFAULT:** -3F SP

NOTE: Allows user to set temp difference from setpoint that W3 is enabled.

OPTION: Heat Stage 3 Off Offset
RANGE: -10F SP to +10F SP **DEFAULT:** +1F SP

NOTE: Allows user to set temp difference from setpoint that W3 is disabled.

OPTION: DeHumidify Off (Y1 Off) Offset
RANGE: -10F SP to +10F SP **DEFAULT:** Off 02F Below SP

OPTION: Cool 3 Off Delay
RANGE: 000S _ 600S **DEFAULT:** C3 Off Delay
 60S (Setting)

NOTE: Allows user to set delay before Y3 goes off after controller deems Y3 isn't required.

OPTION: Cool 4 On Delay
RANGE: 000S _ 600S **DEFAULT:** C4 On Delay
 240S (Setting)

NOTE: Allows user to set delay before Y4 comes on after controller deems Y4 is required.

OPTION: Cool 4 Off Delay
RANGE: 000S _ 600S **DEFAULT:** C4 Off Delay
 60S (Setting)

NOTE: Allows user to set delay before Y4 goes off after controller deems Y4 isn't required.

OPTION: Heat 1 On Delay
RANGE: 000S _ 600S **DEFAULT:** H1 On Delay
 240S (Setting)

NOTE: Allows user to set delay before W1 comes on after controller deems W1 is required.

OPTION: Heat 1 Off Delay
RANGE: 000S _ 600S **DEFAULT:** H1 Off Delay
 60S (Setting)

NOTE: Allows user to set delay before W1 goes off after controller deems W1 isn't required.

OPTION: Heat 2 On Delay
RANGE: 000S _ 600S **DEFAULT:** H2 On Delay
 240S (Setting)

NOTE: Allows user to set delay before W2 comes on after controller deems W2 is required.

OPTION: Heat 2 Off Delay
RANGE: 000S _ 600S **DEFAULT:** H2 Off Delay
 60S (Setting)

NOTE: Allows user to set delay before W2 goes off after controller deems W2 isn't required.

OPTION: Heat 3 On Delay
RANGE: 000S _ 600S **DEFAULT:** H3 On Delay
 30S (Setting)

NOTE: Allows user to set delay before W3 comes on after controller deems W3 is required.

OPTION: Heat 3 Off Delay
RANGE: 000S _ 600S **DEFAULT:** H3 Off Delay
 30S (Setting)

NOTE: Allows user to set delay before W3 goes off after controller deems W3 isn't required.

OPTION: Fan Default Delay
RANGE: 000S _ 255S **DEFAULT:** Fan Fault Delay
 60S (Setting)

CONFIGURATION MENUS (cont.)

CONFIGURATION MISC.

OPTION: CONTROLLER MODE
RANGE: DAT or Space **DEFAULT:** Space
NOTE: Discharge Air Temp Controlled.

OPTION: CONF. # of CONTROL BOARDS
RANGE: 1 or 2 **DEFAULT:** 2 Control Boards
NOTE: Main Controller basic I/O.

OPTION: Conf. # of Heat Stages 1
RANGE: N/A **DEFAULT:** [enabled]
NOTE: Set number of heat stages in unit. If no heat stages select 1 stage.

OPTION: Max Reheat Requirement
RANGE: N/A **DEFAULT:** [enabled]
NOTE: If No max is needed is selected, HGR valve will go from 0-100%.

OPTION: Supp Heat Time Delay
RANGE: 0-300s **DEFAULT:** Supp Heat is disabled
NOTE: If Enabled Default is 30s

OPTION: Config. Heat Pump
RANGE: No Heat Pump **DEFAULT:** No Heat
Yes, Heat Pump 0 Pump [enabled]
Yes, Heat Pump B
NOTE: This is selected for even heat pump if the heat pump logic turns on Y1 & O on W1 command.

OPTION: Reheat Min
RANGE: 001_100 **DEFAULT:** 002
NOTE: If Reheat min is set to 0%, the unit can vapor lock due to lack of fluid flow through reheat coil.

OPTION: Reheat Max
RANGE: 001_100 **DEFAULT:** 075
NOTE: If Reheat max is more than 75%, many times the unit will loose ability to cool.

OPTION: Reheat Multiplier
RANGE: .1_1 **DEFAULT:** .8
NOTE: % Modulating reheat signal = (((Act temp - setpoint temp)+ Reheat Offset)/Reheat Gain) * Reheat Multiplier.

OPTION: Reheat Gain
RANGE: -20_20 **DEFAULT:** 03
NOTE: % Modulating reheat signal = (((Act temp - setpoint temp)+ Reheat Offset)/Reheat Gain) * Reheat Multiplier.

OPTION: Reheat Offset
RANGE: -10_10 **DEFAULT:** 01
NOTE: % Modulating reheat signal = (((Act temp - setpoint temp)+ Reheat Offset)/Reheat Gain) * Reheat Multiplier.

OPTION: BAS Config
RANGE: N/A **DEFAULT:** [enabled]
NOTE: Unit Operates as Standalone.

OPTION: Fan input
RANGE: N/A **DEFAULT:** [selected]
NOTE: Unit has a feedback to ensure supply fan is on. If not unit will not run and go into alarm.

(SPACE/PROCESS ONLY)

OPTION: Room Temp Type
RANGE: N/A **DEFAULT:** [enabled]
NOTE: Allows user to select what type of space sensor is being used.

OPTION: Room Temp Low
RANGE: -40F_80F **DEFAULT:** 032
NOTE: Only Active when Room Temp Type Set to User Defined

OPTION: Room Temp High
RANGE: -40F_95F **DEFAULT:** Mode not active

OPTION: Setpoint Source
RANGE: 60 F_90 F **DEFAULT:** [enabled]
NOTE: When this is enabled, unit is getting room setpoint temperature for iAIRE provided space sensor.

OPTION: Room SetpointLow
RANGE: 050_082 **DEFAULT:** 062

OPTION: Room Setpoint High
RANGE: 062_130 **DEFAULT:** 082

OPTION: Comm Setup
RANGE: N/A **DEFAULT:** [enabled]
NOTE: Default V.4+.

OPTION: Humidit Mode Config
RANGE: 0-10V/0-100% **DEFAULT:** 0-10V/0-100% [enabled]
0-10V/20-80%
User Defined
Remote

OPTION: Humidity Low SP
RANGE: 001_080 **DEFAULT:** 020
NOTE: USER DEFINED

OPTION: Humidity High SP
RANGE: 020_100 **DEFAULT:** 080
NOTE: USER DEFINED

OPTION: Supplemental Heat
RANGE: N/A **DEFAULT:** [enabled]
NOTE: Allows unit to bring on stages of heat if HGR does not have enough heat to get unit to Space or DAT set point temperature.

OPTION: Humidity Override On Delay
RANGE: 000S_600S **DEFAULT:** 180S
NOTE: When Y2 is called on because of humidity, this is the delay the unit will keep Y2 off before it turns on.

OPTION: Humidity Override Off Delay
RANGE: 000S_600S **DEFAULT:** 120S
NOTE: When Y2 is on because of humidity and is no longer needed, this is the delay the unit will keep Y2 on before it shuts it off.

OPTION: Allow Humidity Override Off Delay
RANGE: 000S_600S **DEFAULT:** 300S
NOTE: When Y2 is on because of humidity and the space temperature is below set point, this is the delay the unit will keep Y2 on before it shuts it off.

OPTION: Freeze Protection
RANGE: Off < 33_45 F **DEFAULT:** 039
NOTE: On at 39 F.

OPTION: Freeze Timer
RANGE: 000S_600S **DEFAULT:** 300S
NOTE: Freeze time 300 seconds.

OPTION: Water Guard Config
RANGE: Disabled/Enabled **DEFAULT:** Disabled

OPTION: Load Defaults
ARE YOU SURE???? Press Enter

CONFIGURATION MENUS (2 Control Boards Only)

OPTION: Mod Heat Config

RANGE: N/A **DEFAULT:** [enabled]

NOTE: This is selected if unit is all electric unit.

OPTION: Config # of Cooling Stages

RANGE: # of Cool Stages 1_4 **DEFAULT:** # of Cool Stages 2

NOTE: Select # of cooling stages the unit has.

OPTION: Configure Heat Type

RANGE: N/A **DEFAULT:** [enabled]

NOTE: Select if the unit has modulating heat or not.

OPTION: Modulated Heat Min

RANGE: 000 _ 100 **DEFAULT:** 000

NOTE: Sets minimum % output from controller to modulating heat valve.

OPTION: Modulated Heat Max

RANGE: 000 _ 100 **DEFAULT:** 100

NOTE: Sets minimum % output from controller to modulating heat valve - This will limit max firing of heater.

OPTION: Modulated Heat Gain

RANGE: -20 _ 20 **DEFAULT:** 04

NOTE: % Modulating heat signal = (((Act temp - setpoint temp)+ Mod Heat Offset)/Modulated Heat Gain) * Mod Heat Multiplier.

OPTION: Modulated Heat Offset

RANGE: -10 _ 10 **DEFAULT:** 00

NOTE: % Modulating heat signal = (((Act temp - setpoint temp)+ Mod Heat Offset)/Modulated Heat Gain) * Mod Heat Multiplier.

OPTION: Modulated Heat Multiplier

RANGE: .1 _ 1 **DEFAULT:** 1

NOTE: % Modulating heat signal = (((Act temp - setpoint temp)+ Mod Heat Offset)/Modulated Heat Gain) * Mod Heat Multiplier.

OPTION: Mod Heat Wait Time

RANGE: 000S_300S **DEFAULT:** 030S

OPTION: Mod Heat DAT Max

RANGE: 90F _ 130F **DEFAULT:** 110F

OPTION: LAT Average

RANGE: ON/OFF **DEFAULT:** ON

OPTION: Min Compressor Voltage

RANGE: 0_9.9V **DEFAULT:** 07.5V

OPTION: Max Compressor Voltage

RANGE: 0_10V **DEFAULT:** 10.0V

OPTION: Control from LAT1 or Average

RANGE: Use LAT1 **DEFAULT:** Use LAT Average

Use LAT Average

X*1 Sec

OPTION: Compressor Fast Rate

RANGE: 001_100 **DEFAULT:** 001

X*1 Sec

OPTION: Compressor Slow Rate

RANGE: 001_200 **DEFAULT:** 005

OPTION: Compressor Slow Point

RANGE: 0-100% **DEFAULT:** Slow Point 013 <enabled>

CONFIGURATION MENUS (Config VAV)

VAV MODE CONFIGURATION

OPTION: VAV mode off
 RANGE: N/A DEFAULT: [enabled]
 NOTE:

OPTION: Duct Pressure
 RANGE: N/A DEFAULT: [disabled]
 NOTE:

OPTION: Build. Pressure
 RANGE: N/A DEFAULT: [disabled]
 NOTE:

(if duct or build pressure
is [enabled])

SET MIN FAN SPEED

RANGE: 000_100 DEFAULT: 40
 NOTE:

SET MAX FAN SPEED

RANGE: 000_100 DEFAULT: 100
 NOTE:

ADJUST FAST RATE

RANGE: 000_100 DEFAULT: 001
 NOTE: X * 0.5 seconds

ADJUST SLOW RATE

RANGE: 000_050 DEFAULT: 005
 NOTE: X * 0.5 seconds

SELECT SLOW POINT

RANGE: 000_100 DEFAULT: 013
 NOTE:

SELECT TRANSDUCER TYPE

RANGE: 0in to +1in_-5in to 5in DEFAULT: 0in to +2in
 NOTE:

SELECT DAMPER/ FAN CONTROL

OPTION: Fan Control
 RANGE: N/A DEFAULT: [enabled]
 NOTE:

OPTION: Damper Control
 RANGE: N/A DEFAULT: [disabled]
 NOTE:

CONFIGURATION MENUS (Config ERV)

ERV MODE CONFIGURATION

OPTION: ERV mode off
 RANGE: N/A DEFAULT: [enabled]
 NOTE:

OPTION: ERV mode
 RANGE: N/A DEFAULT: [disabled]
 NOTE:

(if ERV mode is [enabled])

SET OA FAN SPEED

RANGE: 000_100 DEFAULT: 50
 NOTE:

SET EA FAN SPEED

RANGE: 000_100 DEFAULT: 50
 NOTE:

SET DAMPER POSITION

RANGE: 000_100 DEFAULT: 100
 NOTE:

SET ERV FREEZE TIME

RANGE: 060S_540S DEFAULT: 300S
 NOTE:

ALARMS MENU

BAS COMM OK

RANGE: N/A DEFAULT: N/A

DIRTY FILTER

RANGE: N/A DEFAULT: N/A

FRZ1 SENSOR

RANGE: N/A DEFAULT: N/A

FRZ2 SENSOR OK

RANGE: N/A DEFAULT: N/A

NOTE: [Enabled] two stages of cooling.

FAN FAULT

RANGE: N/A DEFAULT: N/A

ACCESSORY BOARD MENUS

ACC V *.*.*
ADDRESS *

NOTE: Addr [Changes based on "set address input"] [CKS/FILTER]

SAVE ADDRESS

RANGE: 0_6 DEFAULT: 0

NOTE:

SET RX MODE

RANGE: N/A DEFAULT: N/A

NOTE: Options: Filter, CKS [Setting]

MISC CONTROLLER INFORMATION

- Solid red light indicates unit shutdown.
- Flashing red light indicates alarm with no unit shutdown.
- Mode 1: Cooling
- Mode 2: Heating
- Mode 3: Unit in free cooling

Accessory Board Addresses:

- 0: 1st main accessory board
- 2: ERV accessory board



BACNET OPTION WIRING

SCH-0006-0

REVISION: V5.0.0.5

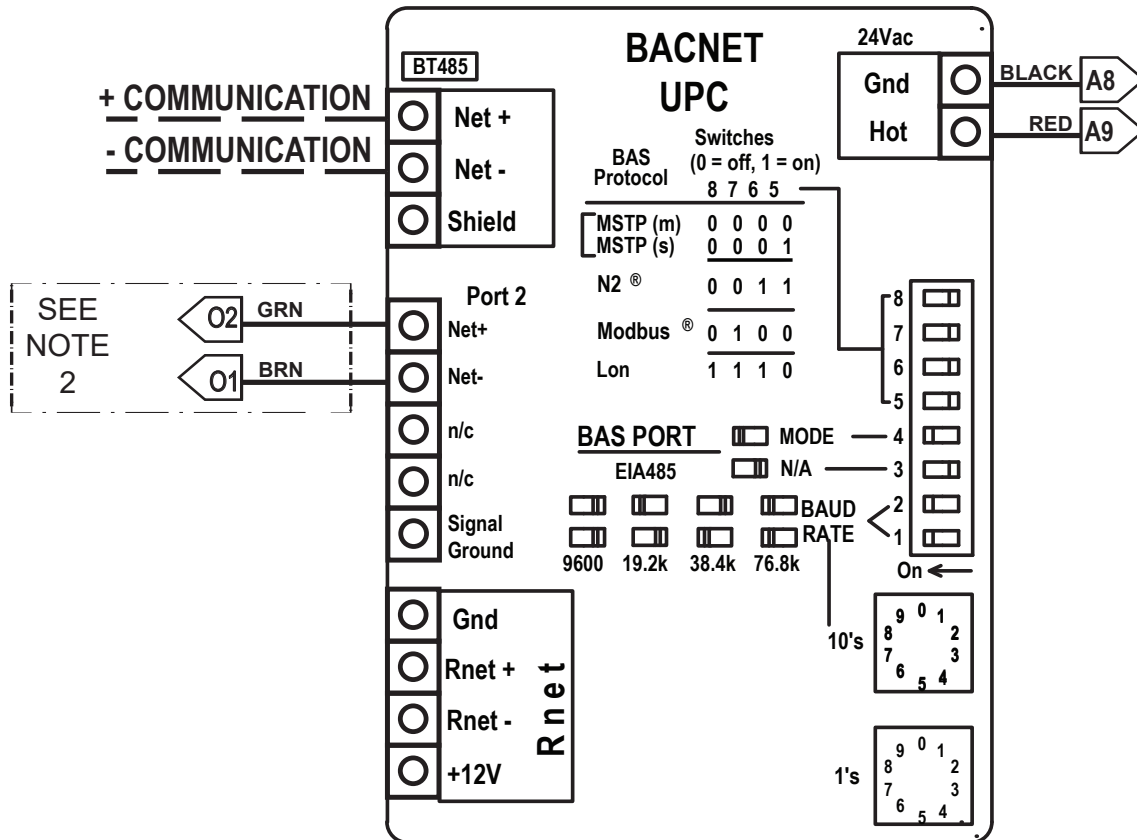

— — — FIELD SUPPLIED WIRING

NOTE 1: BacNet Communication Has 3 Minute Delay upon Power Up

NOTE 2: All Communication Wires Between BacNet and iAire Controllers must be Shielded Wire

BACNET POINTS LIST

OBJECT ID	iAIRE POINT NAME	POINT TYPE	BACNET OBJECT NAME	OBJECT TYPE	DEFAULT SET POINTS	READ ACCESS
1	FAN STATUS AV	ANALOG	fan_status_av	AV	0%	READ ONLY
1	FAN FAULT	DIGITAL	fan_fault	BV	N/A	READ ONLY
1	UNIT CONTROL		unit_control	MSV	N/A	READ ONLY
2	ENTERING AIR TEMP	ANALOG	ea_temp	AV	58.6°F	READ ONLY
2	COOLING 1	DIGITAL	cooling_1	BV	N/A	READ ONLY
3	LEAVING AIR TEMP	ANALOG	la_temp	AV	57.6°F	READ ONLY
3	COOLING 2	DIGITAL	cooling_2	BV	N/A	READ ONLY
4	DISCHARGE AIR TEMP	ANALOG	da_temp	AV	57.6°F	READ ONLY
4	COOLING 3	DIGITAL	cooling_3	BV	N/A	READ ONLY
5	HUMIDITY	ANALOG	humidity	AV	0%rh	READ ONLY
5	COOLING 4	DIGITAL	cooling_4	BV	N/A	READ ONLY
6	VERSION D3.0	ANALOG	version_number	AV	No Units	READ ONLY
6	HEATING 1	DIGITAL	heating_1	BV	N/A	READ ONLY
7	HOT GAS REHEAT	ANALOG	hot_gas_reheat	AV	0%	READ ONLY
7	HEATING 2	DIGITAL	heating_2	BV	N/A	READ ONLY
8	VFD SPEED	ANALOG	vfd_speed	AV	50%	READ ONLY
8	HEATING 3	DIGITAL	heating_3	BV	N/A	READ ONLY
9	ROOM TEMP	ANALOG	room_temp	AV	32°F	READ ONLY
9	FAN ENABLE	DIGITAL	fan_enable	BV	N/A	READ ONLY
10	ROOM TEMP SETPOINT	ANALOG	room_temp_stp	AV	62°F	READ ONLY
10	DIRTY FILTER	DIGITAL	dirty_filter	BV	N/A	READ ONLY
11	DUCT OR BUILDING PRESSURE	ANALOG	duct_or_buildingpressure	AV	0 in H ₂ O	READ ONLY
11	WATER GUARD	DIGITAL	water_guard	BV	N/A	READ ONLY
12	FREEZE1	DIGITAL	freeze_1	BV	N/A	READ ONLY
13	FREEZE2	DIGITAL	freeze_2	BV	N/A	READ ONLY
14	BAS VFD SPEED COOL	ANALOG	bas_vfd_speed_cool	AV	50%	READ / WRITE
14	FAN STATUS BV	DIGITAL	fan_status_bv	BV	N/A	READ ONLY
15	BAS VFD SPEED HEAT	ANALOG	bas_vfd_speed_heat	AV	50%	READ / WRITE
16	BAS DAT SETPOINT	ANALOG	bas_dat_stp	AV	72°F	READ / WRITE
17	BAS ROOM SETPOINT	ANALOG	bas_room_setpoint	AV	72°F	READ / WRITE
18	BAS HUMIDITY LOCKOUT	ANALOG	bas_humidity_lout	AV	50%rh	READ / WRITE
19	BAS HUMIDITY LOCKOUT 2	ANALOG	bas_humidity_lout2	AV	55%rh	READ / WRITE
20	BAS EAT COOL LOCKOUT	ANALOG	bas_eat_cool_lout	AV	61°F	READ / WRITE
21	BAS EAT DEAD BAND	ANALOG	bas_eat_dead_band	AV	3°F	READ / WRITE
22	BAS SWITCH (OCC)	ANALOG	bas_switch	AV	1	READ / WRITE
23	BAS LAT SETPOINT	ANALOG	bas_lat_sp	AV	55°F	READ / WRITE
24	VFD SPEED COOL	ANALOG	vfd_speed_cool	AV	%	READ ONLY
25	VFD SPEED HEAT	ANALOG	vfd_speed_heat	AV	%	READ ONLY
26	DAT SETPOINT	ANALOG	dat_stp	AV	°F	READ ONLY
27	ROOM SETPOINT	ANALOG	roomsetpoint	AV	°F	READ ONLY
28	HUMIDITY LOCKOUT	ANALOG	humidity_lockout	AV	%rh	READ ONLY
29	HUMIDITY LOCKOUT 2	ANALOG	humidity_lockout2	AV	%rh	READ ONLY
30	LAT SP	ANALOG	lat_sp	AV	°F	READ ONLY
31	EAT COOL LOCKOUT	ANALOG	eat_cool_lockout	AV	°F	READ ONLY
32	EAT HEAT LOCKOUT	ANALOG	eat_heat_lout	AV	°F	READ ONLY
34	SWITCH	ANALOG	switch	AV	N/A	READ ONLY
35	BAS PRESSURE SETPOINT	ANALOG	bas_pressure_sp	AV	1.2 in H ₂ O	READ / WRITE
36	PRESSURE SETPOINT	ANALOG	pressure_setpoint	AV	in H ₂ O	READ ONLY
37	MINIMUM FAN SPEED	ANALOG	minimum_fan_speed	AV	%	READ ONLY

BACNET POINTS LIST (cont.)

OBJECT ID	iAIRE POINT NAME	POINT TYPE	BACNET OBJECT NAME	OBJECT TYPE	DEFAULT SET POINTS	READ ACCESS
38	BAS MINIMUM FAN SPEED	ANALOG	bas_min_fan_speed	AV	40%	READ / WRITE
39	MAXIMUM FAN SPEED	ANALOG	maximum_fan_speed	AV	100%	READ ONLY
40	BAS MAXIMUM FAN SPEED	ANALOG	bas_max_fan_speed	AV	80%	READ / WRITE
41	OA FAN SPEED	ANALOG	outsideair_fan_speed	AV	50%	READ ONLY
42	BAS OA FAN SPEED	ANALOG	bas_oa_fan_speed	AV	50%	READ / WRITE
43	EAFAN SPEED	ANALOG	exhaustair_fan_speed	AV	50%	READ ONLY
44	BAS EA FAN SPEED	ANALOG	bas_ea_fan_speed	AV	50%	READ / WRITE
45	DAMPER POSITION	ANALOG	damper_position	AV	0%	READ ONLY
46	BAS DAMPER POSITION	ANALOG	bas_damper_position	AV	100%	READ / WRITE
47	FREEZE PROTECTION	ANALOG	freeze_protection	AV	39°F	READ ONLY
48	BAS FREEZE PROTECTION	ANALOG	bas_freeze_protection	AV	39°F	READ / WRITE

Residential Split Troubleshooting

9. Troubleshooting

9.1. Control logic description

1. Display board button function

▲ button: check button、setting button“+”

▼ button: check button、setting button“-”

■ button:

A、Short press: force cooling mode, display board will show “dH”;

B、Long press: entering test mode, and you can change unit parameter manually:

When it show “Sc.”, then you can set Compressor Frequency manually, using “▲” and “▼”to change frequency.

Then press “■” button, display board will show “SF.”, then you can set fan speed manually, using “▲” and “▼”to change fan speed.

Then press “■” button, display board will show “SL.”, then you can set expansion valve open degree manually, using “▲” and “▼”to change expansion valve opening degree.

Then press “■” button, display board will show “SP.”, then you can set PFC switch manually, (0 means OFF, 1 means ON), using “▲” and “▼” to set PFC switch ;

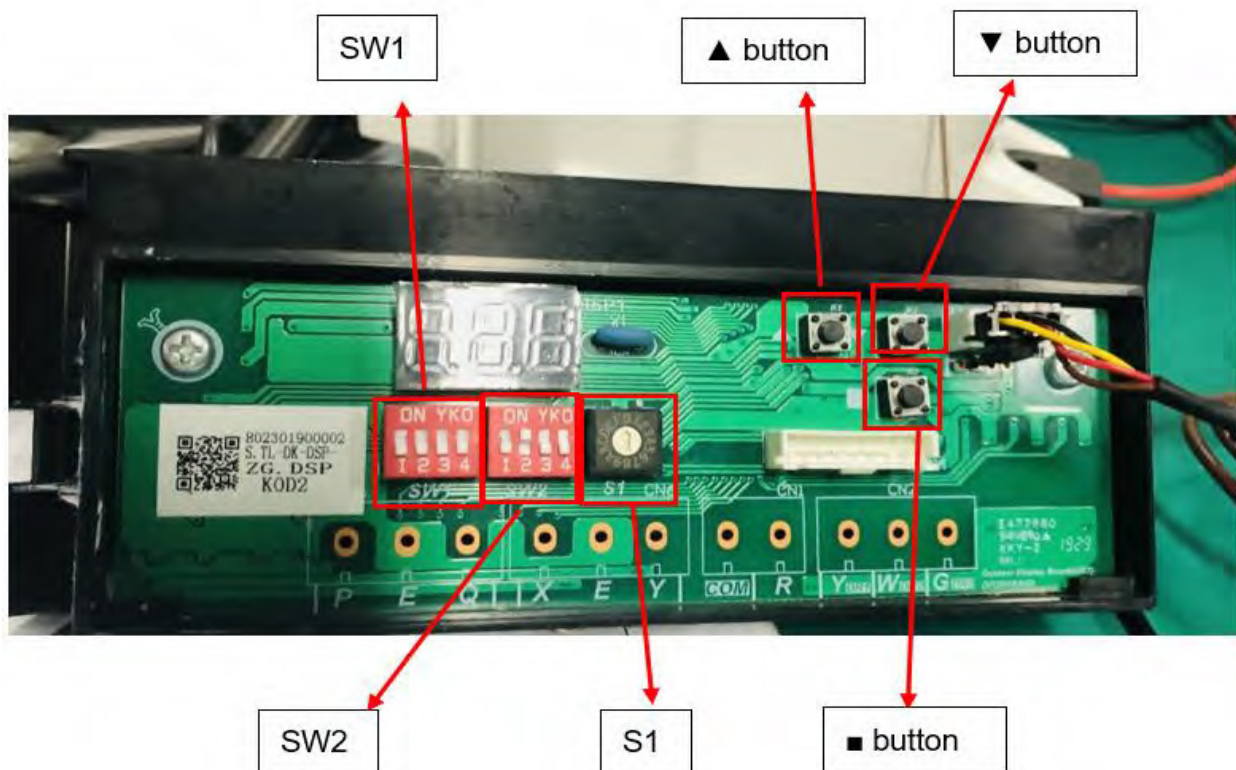

Residential Split Troubleshooting (cont'd)

SW1:

1st bit	2nd bit	3rd bit	4th bit
Outdoor unit control logic(target evaporator temperature and target condensation temperature) setting, manufacture only.			ON: EXV throttling in cooling mode OFF: Piston throttling in cooling mode The function will be active after unit power off and power on.

SW2:

1st bit	2nd bit	3rd bit	4th bit
ON: Manually defrost. OFF: Automatic defrost The function will be active immediately after bit change.	ON: Display as Fahrenheit OFF: Display as Celsius The function will be active after unit power off and power on.	Reserved	ON: EXV throttling in heating mode OFF: Piston throttling in heating mode The function will be active after unit power off and power on.

S1: Reserved

Residential Split Troubleshooting (cont'd)

9.2 Parameter point check table

1). Top discharge outdoor unit

For 24/36K model

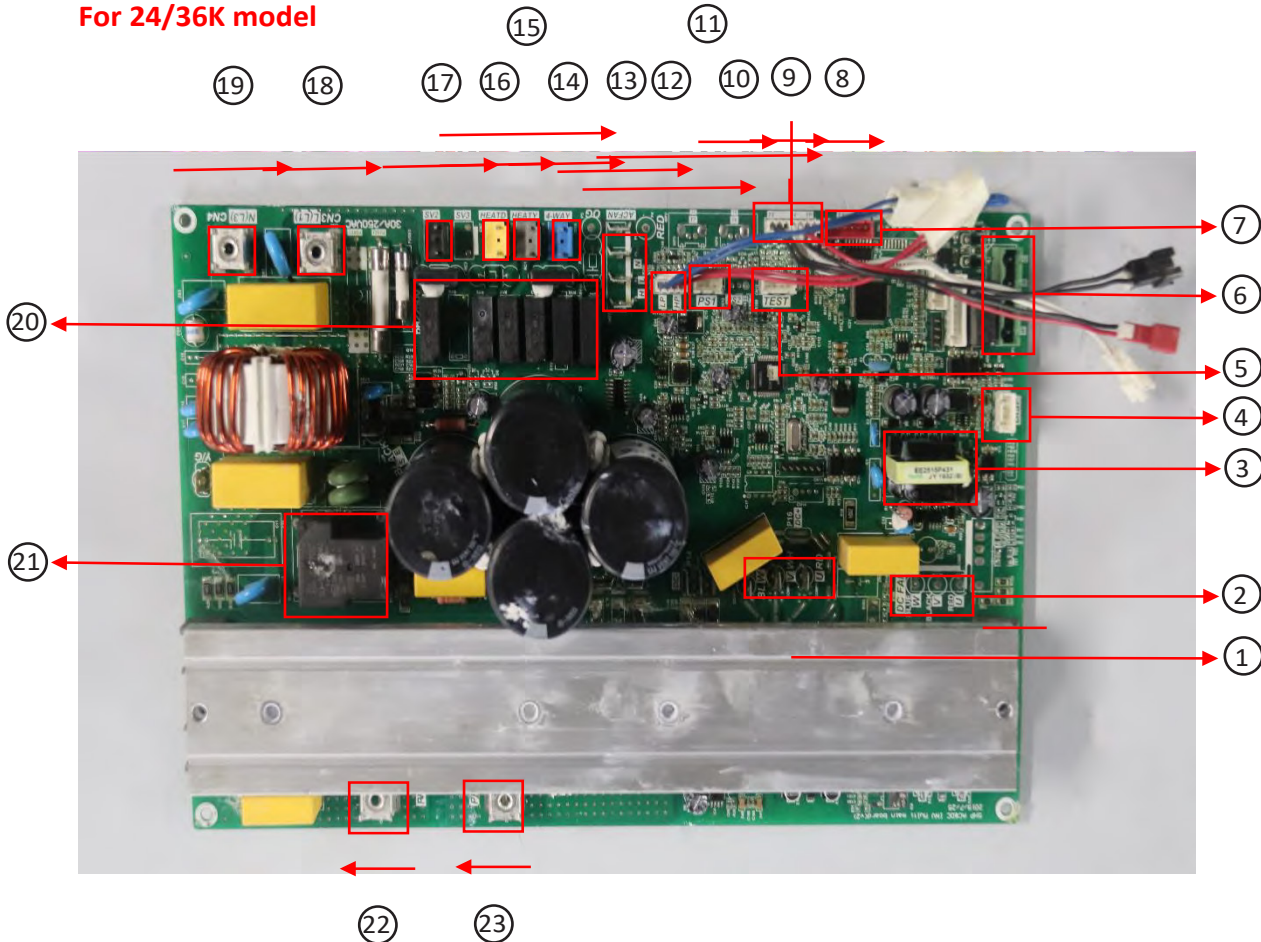

Function description for the corresponding position:

No.	Content	No.	Content
1	Compressor wiring terminal	12	High/Low pressure switch ports
2	DC fan motor wiring terminal	13	AC fan motor wiring terminal
3	Transformer	14	Four-way valve control port
4	Outdoor display board wiring terminal	15	Crankcase Heating zone control terminal
5	Reserved	16	Chassis Electric Heater control terminal
6	24V wire controller interface	17	Solenoid valve2 control terminal
7	EXV drive port	18	Power supply connecting terminal
8	Exhaust temperature sensor port(T5)	19	Power supply connecting terminal
9	Outdoor ambient temperature sensor port(T4)	20/21	Relay
10	Condenser temperature sensor port(T3)	22	Inductor wiring terminal 1
11	Pressure sensors ports	23	Inductor wiring terminal 2

Residential Split Troubleshooting (cont'd)

For 48/60K model

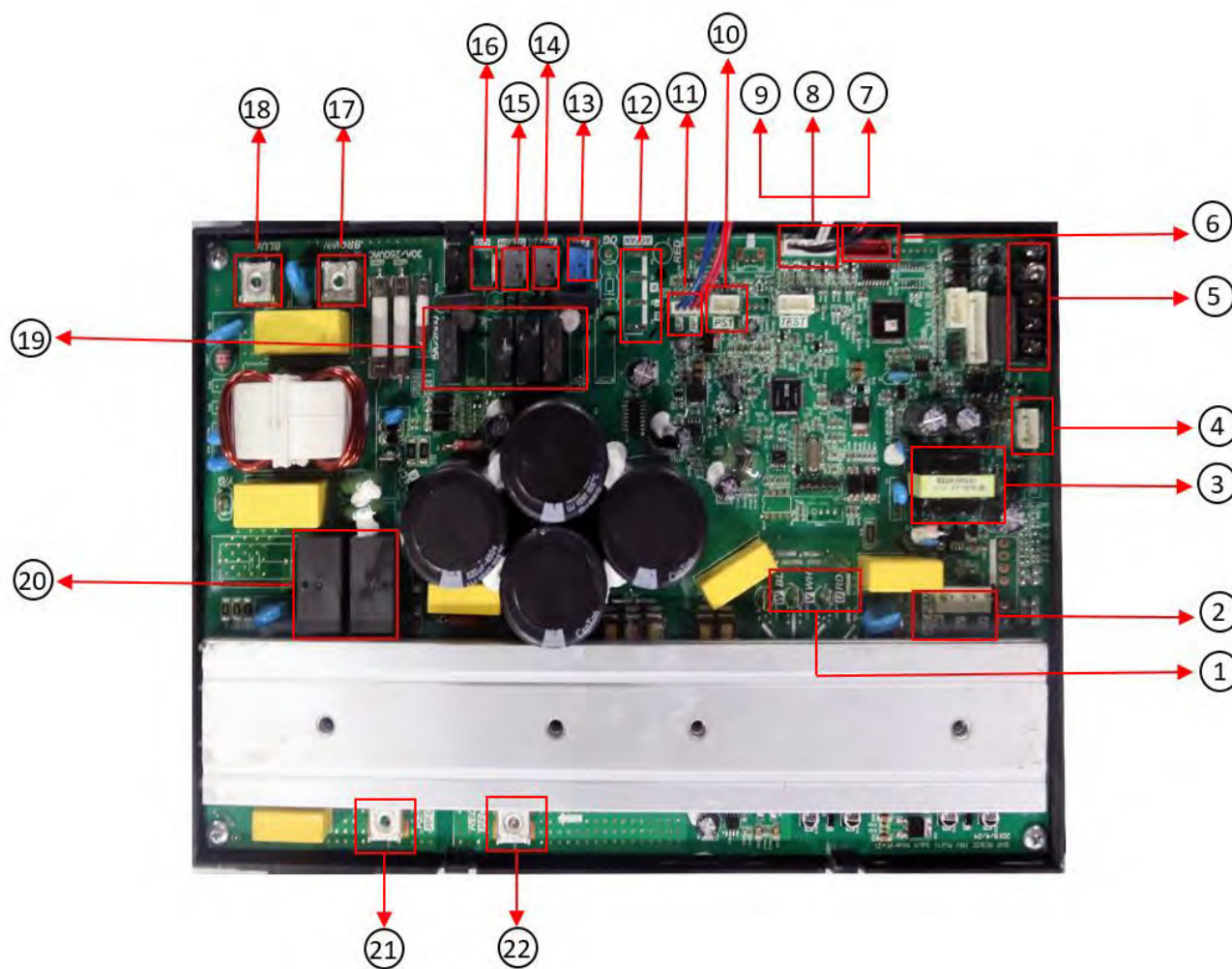

Function description for the corresponding position:

No.	Content	No.	Content
1	Compressor wiring terminal	12	AC fan motor wiring terminal
2	DC fan motor wiring terminal	13	Four-way valve control port
3	Transformer	14	Crankcase Heating zone control terminal
4	Outdoor display board wiring terminal	15	Chassis Electric Heater control terminal
5	24V wire controller interface	16	Solenoid valve control terminal
6	EXV drive port	17	Power supply connecting terminal
7	Exhaust temperature sensor port(T5)	18	Power supply connecting terminal
8	Outdoor ambient temperature sensor port(T4)	19	Relay
9	Condenser temperature sensor port(T3)	20	Relay
10	Pressure sensors ports	21	Inductor wiring terminal 1
11	High/Low pressure switch ports	22	Inductor wiring terminal 2

Residential Split Troubleshooting (cont'd)

9.3 Error codes

CODE	FAULT DESCRIPTION
E4	T4 Outdoor ambient temperature sensor error
E5	T5 Discharge temperature sensor error
E6	T3 Condenser temperature sensor error
E9	AC under voltage protection
E10	EEPROM error
E12	IPM modular sensor error
E13	HLP Pressure sensor error
E14	T3 or T5 sensor disconnect error
E15	High pressure switch error
H0	Communication error of main chip and IPM chip
H1	T3 sensor high temperature error(In cooling mode) (20 times P5 error within 180mins)
H2	High pressure switch error(20 times P1 error within 150 mins)
H3	High pressure abnormal in heating mode (20 times P13 error within 180 mins)
H4	IPM modular high temp error (20 times P8 within 120 mins)
H5	Low pressure error (20 times P2 within 100 mins)
H6	Discharge temperature abnormal error(20 times P4 within 100 mins)
H7	Wet operation error (20 times P12 within 200 mins)
H8	T3 condenser sensor disconnect error (20 times E14 within 100 mins)
H12	Discharge temp sensor disconnect error(20 times E14 within 180 mins)
P1	High pressure protection
P2	Low pressure protection
P3	DC over current protection
P4	T5 Discharge temperature abnormal error
P5	T3 Condenser sensor high temp protection(In cooling mode)
P6	IPM module protection
P8	IPM high temperature protection (Ft)M high temperature protection (Ft)
P9	DC fan motor error
P12	Wet operation error
P13	High pressure abnormal error(In heating mode)
P14	High compression ratio protection
P15	Low compression ratio protection
L1	DC cable bus low voltage protection

Residential Split Troubleshooting (cont'd)

9.3 Error codes continued

L2	DC cable bus high voltage protection
L4	MCE fault / sync / closed loop
L5	Zero speed protection
L7	Compressor phase loss protection ratio protection
L8	Compressor stalls
L9	Frequency limitation or decline by high pressure
LA	Frequency limitation by voltage
LC	Frequency limitation by condenser temp.
LD	Frequency limitation by discharge temp
LE	Frequency limitation by IPM modular high temp
LF	Frequency limitation by current
d0	Oil return
dF	Defrost
dH	Force cooling

Residential Split Troubleshooting (cont'd)

9.4 Troubleshooting guidelines

E4/E5/E6 (T4/T5/T3 temperature sensors error)

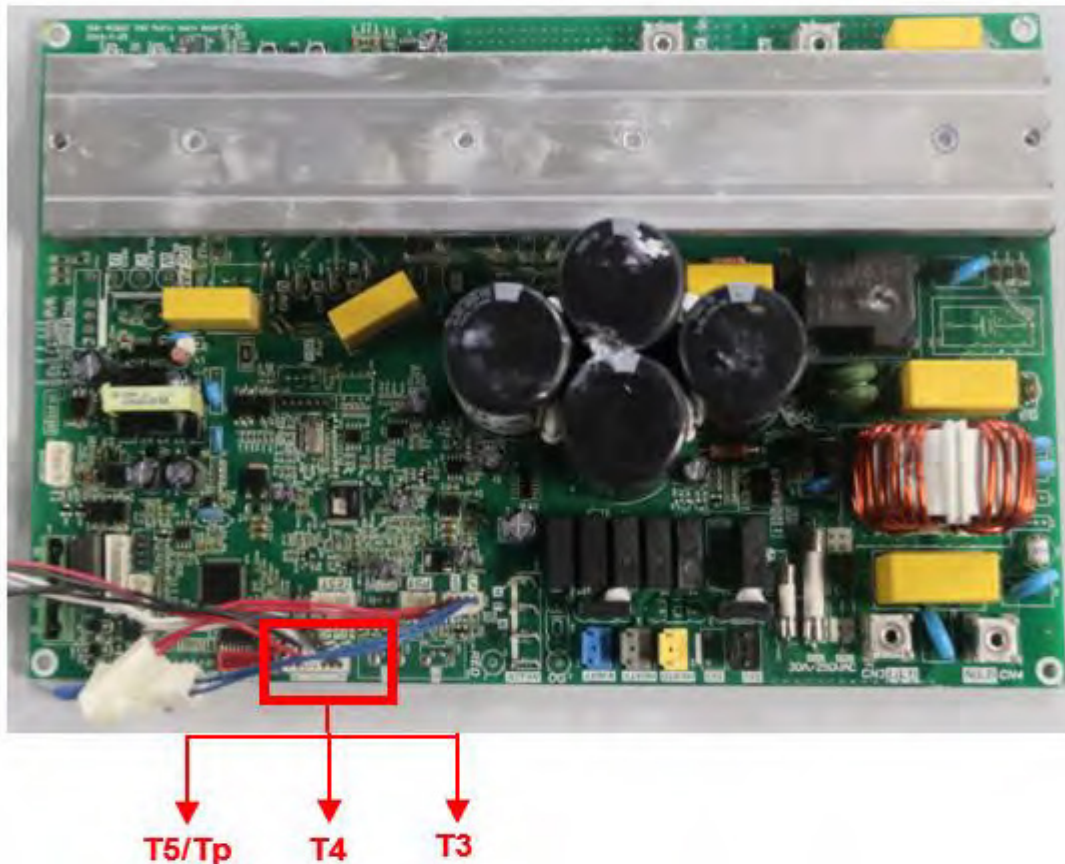
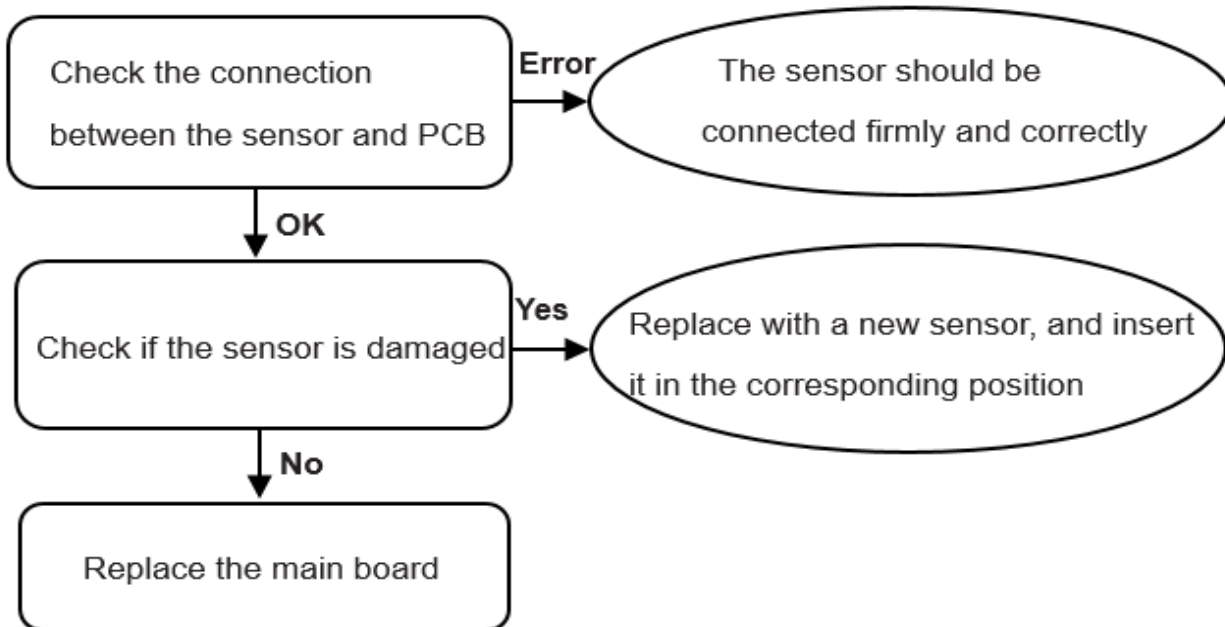

Residential Split Troubleshooting (cont'd)

E9 (AC under voltage protection)

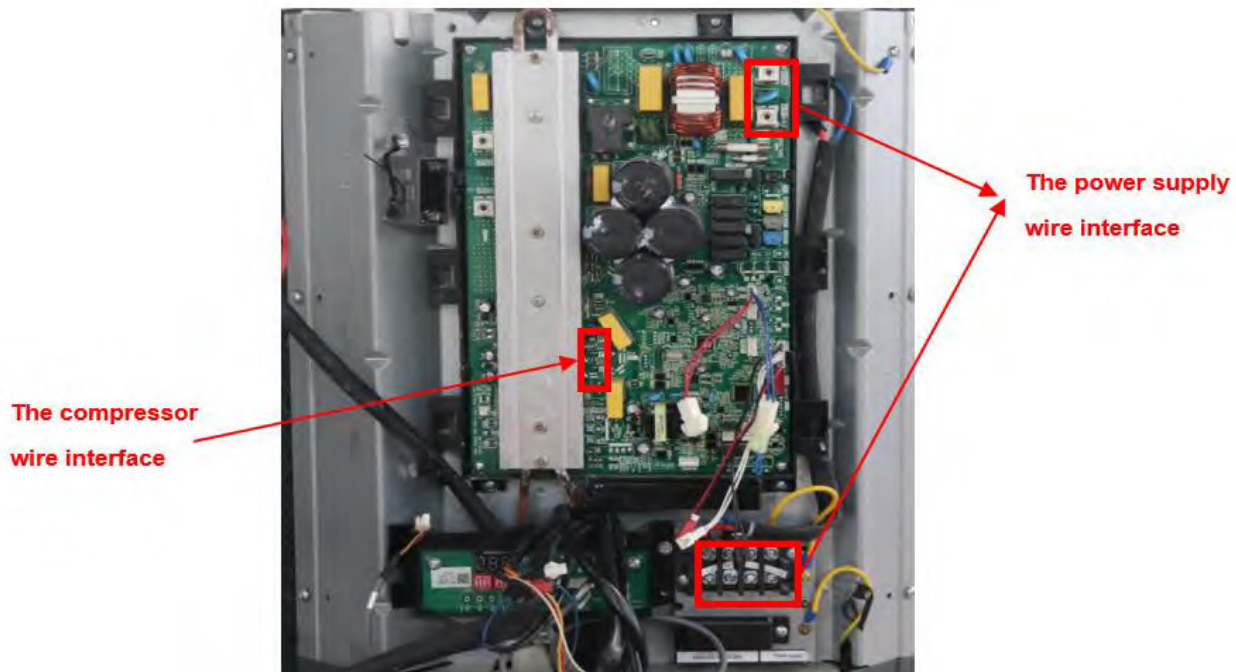
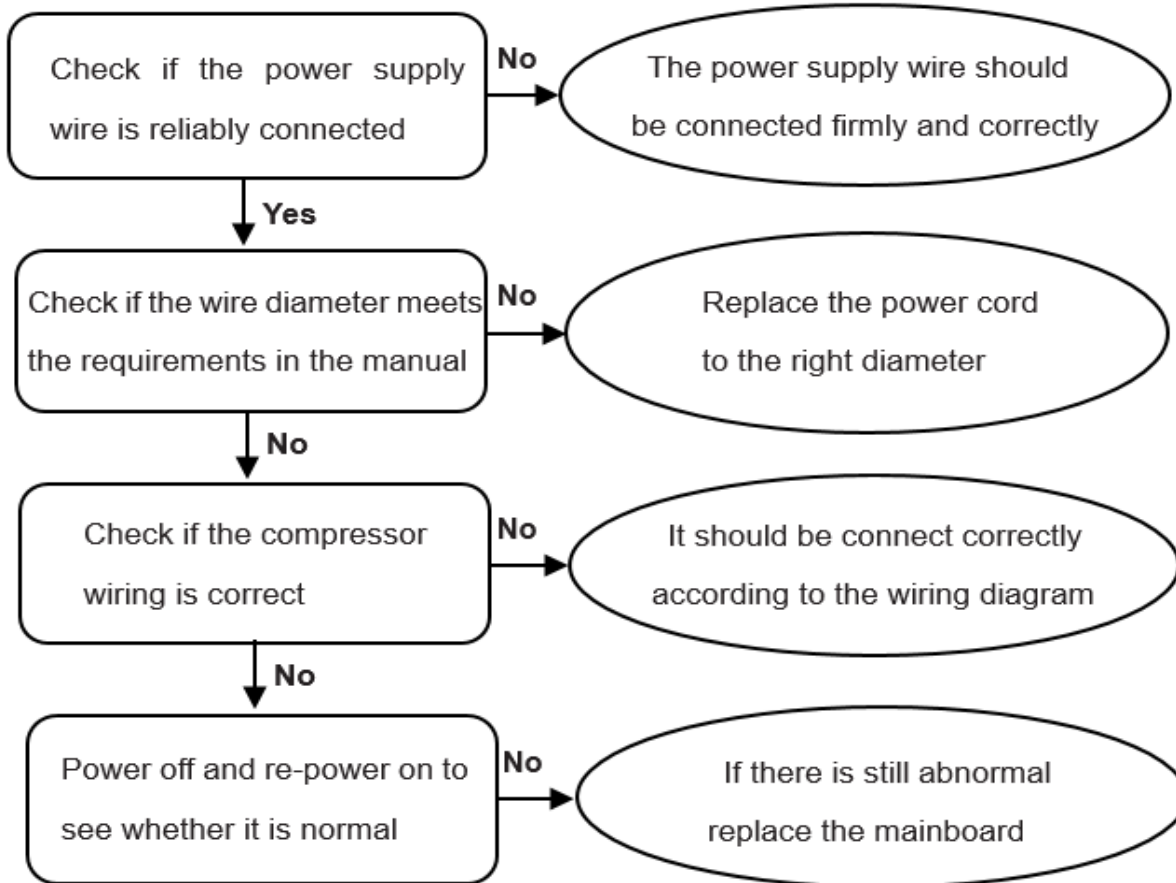

Residential Split Troubleshooting (cont'd)

E10 (EEPROM failure)

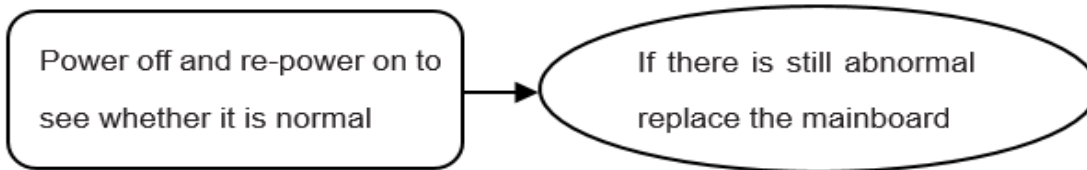

E12 (IPM modular sensor error)

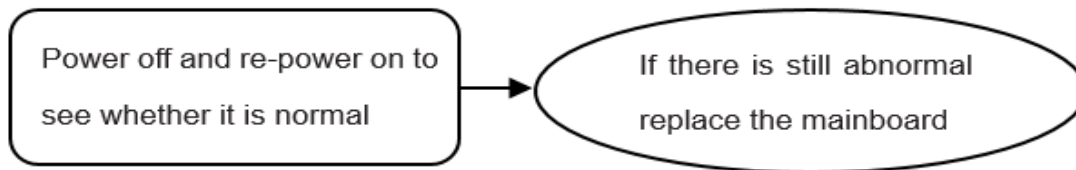

E13 (HLP Pressure sensor error)

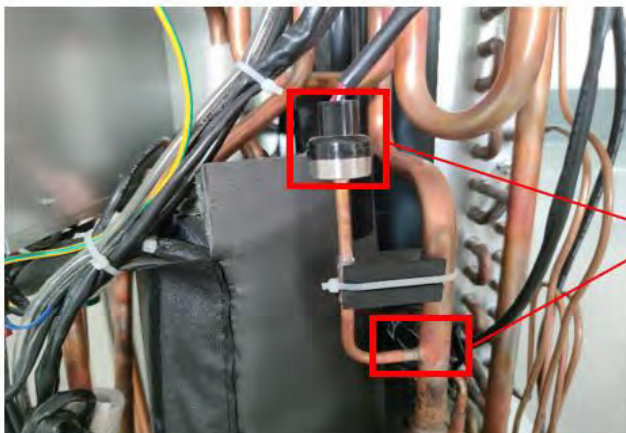
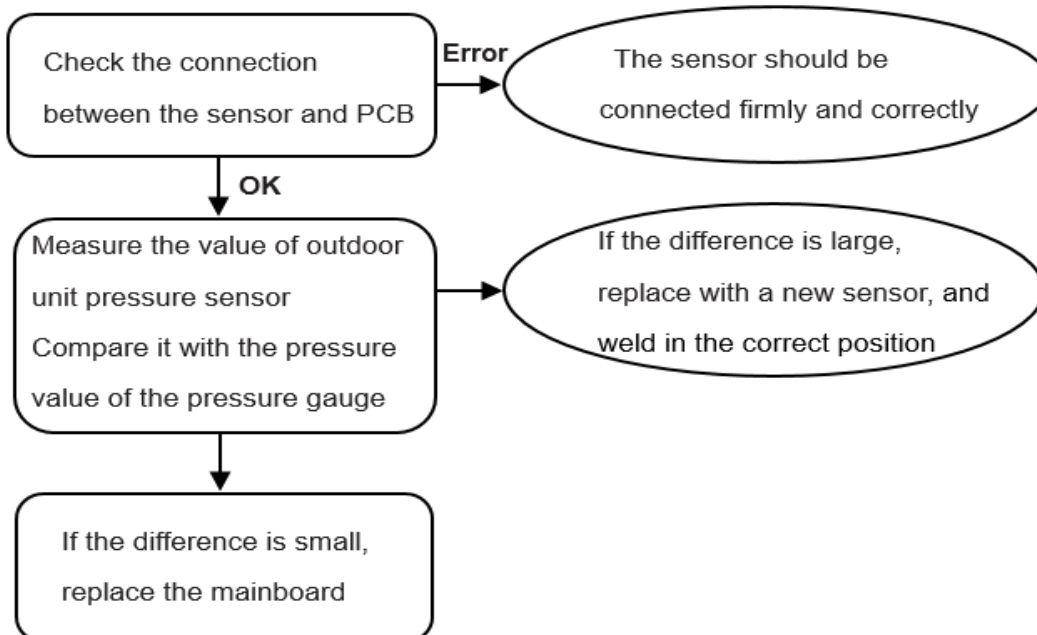

The pressure sensor should be soldered in the correct position

Residential Split Troubleshooting (cont'd)

E14/H8/H12 (T3 or T5 sensor disconnect error)

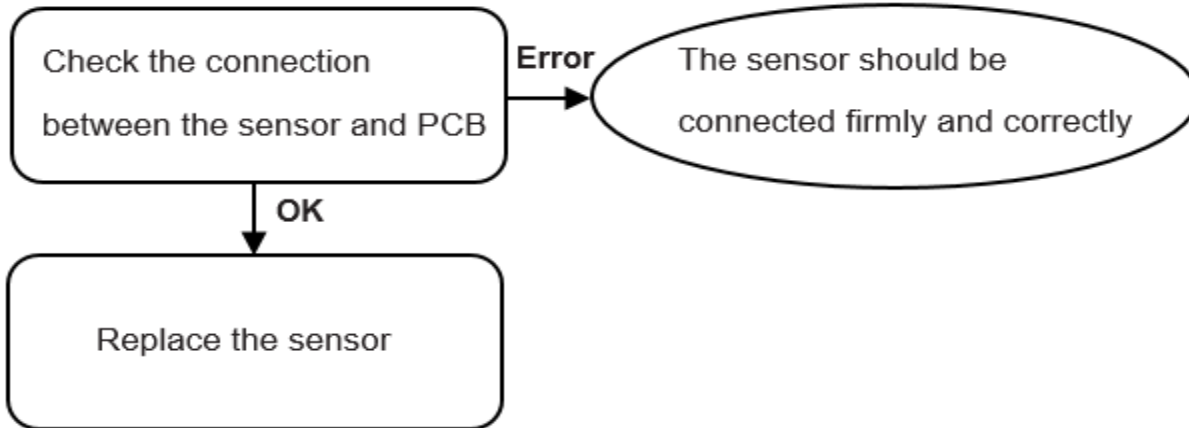

E15 (High pressure switch error)

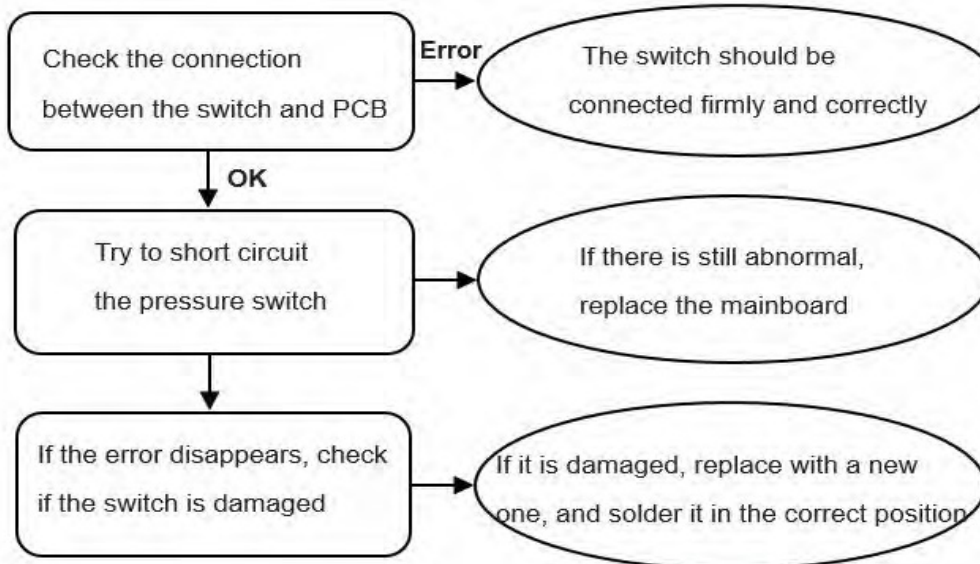

The high pressure switch should be soldered in the correct position

Residential Split Troubleshooting (cont'd)

H0 (Communication error of main chip and IPM chip)

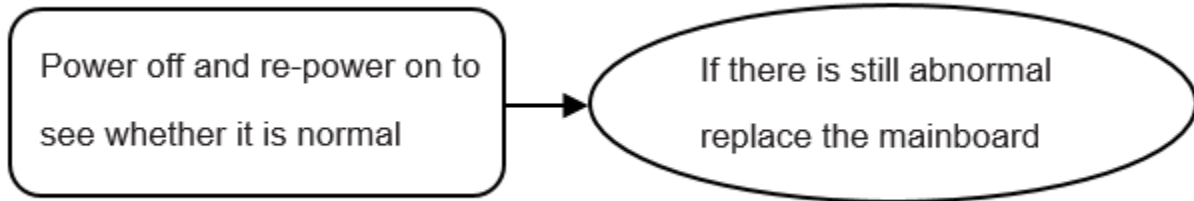

P1/H2 (High pressure switch protection)

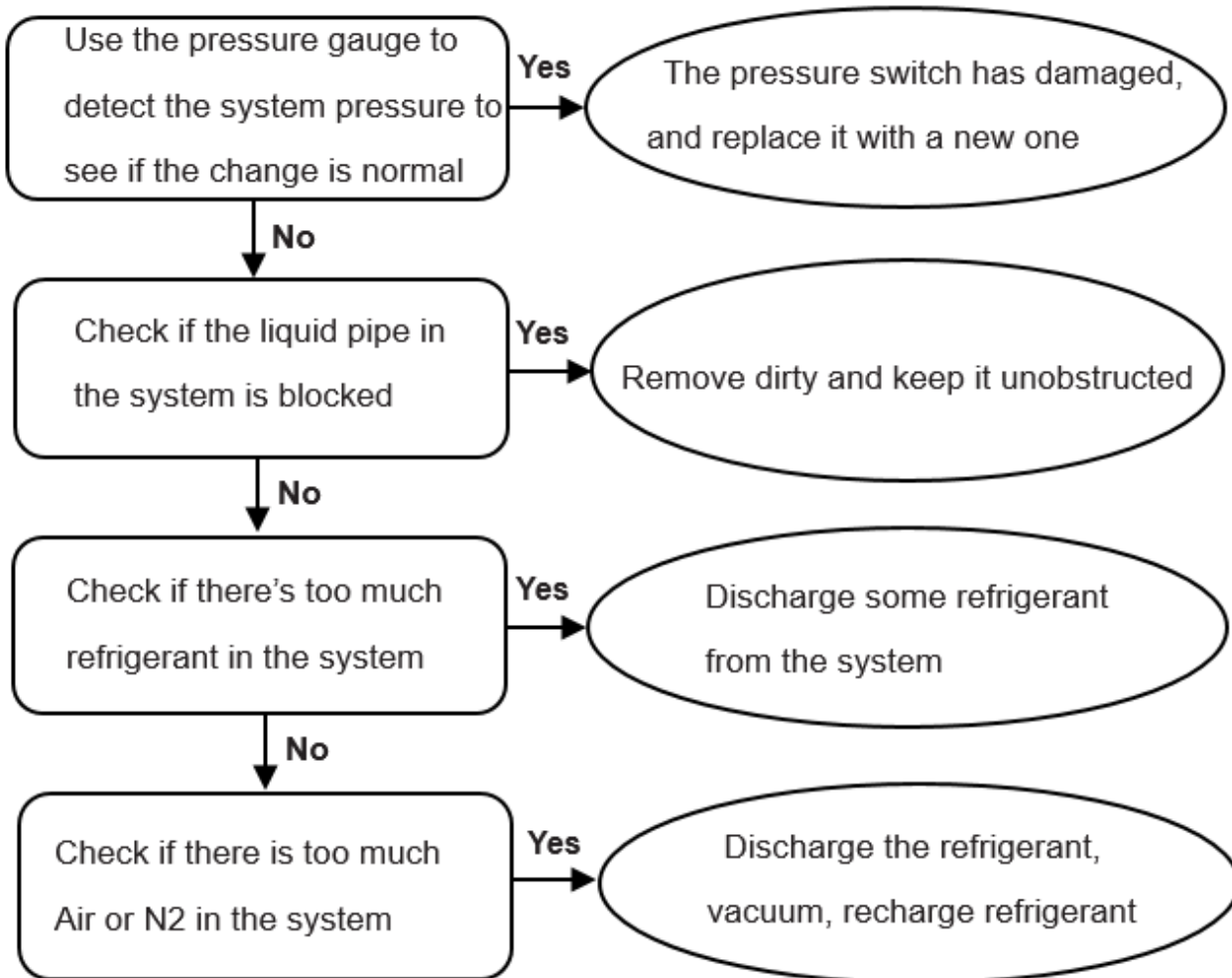

Residential Split Troubleshooting (cont'd)

P2/H5 (Low pressure switch protection)

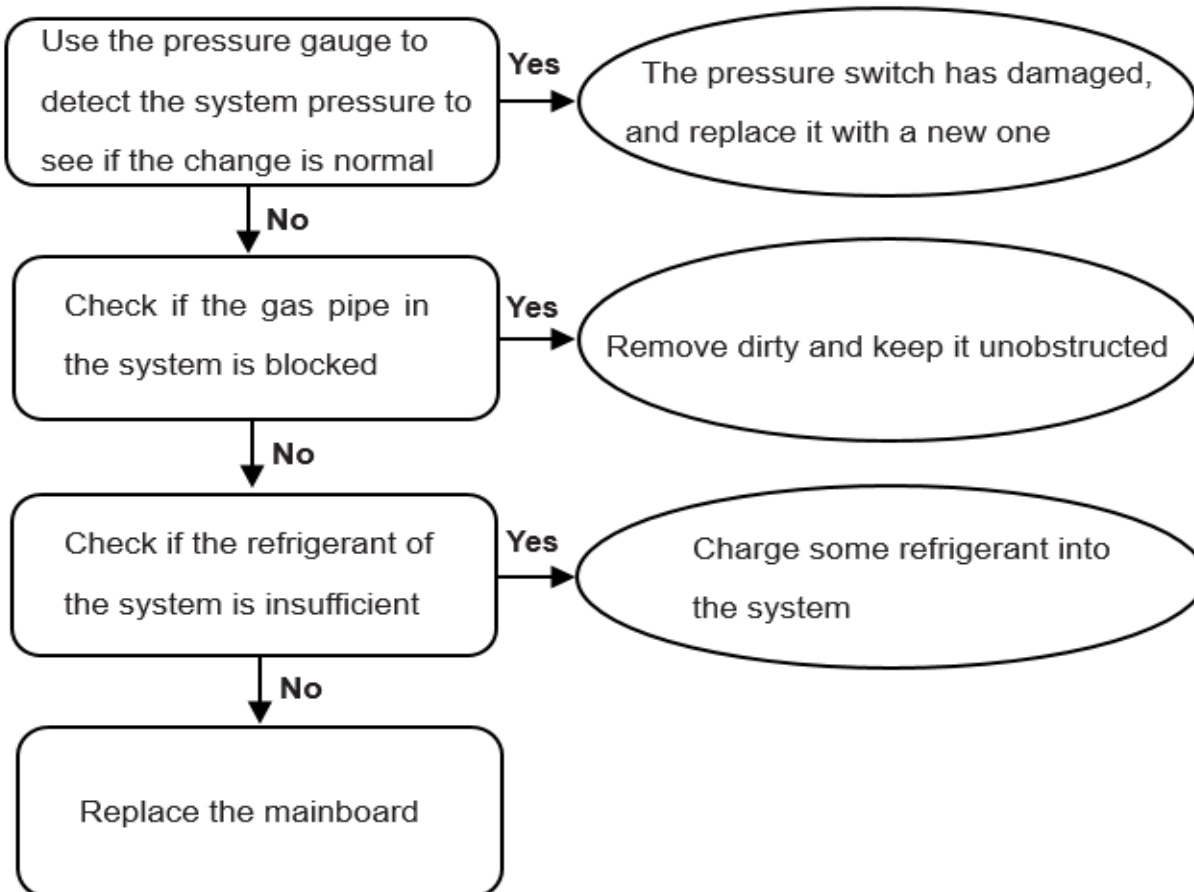

P3 (Inverter over current protection)

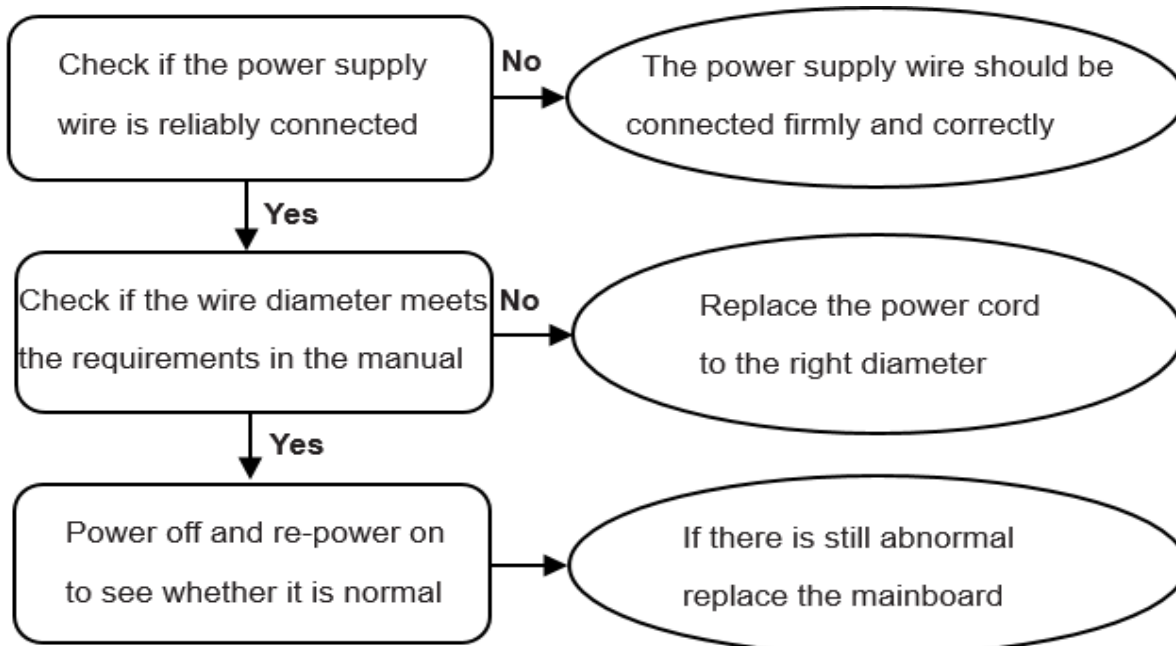

Residential Split Troubleshooting (cont'd)

P4/H6 (T5 Discharge temperature abnormal error)

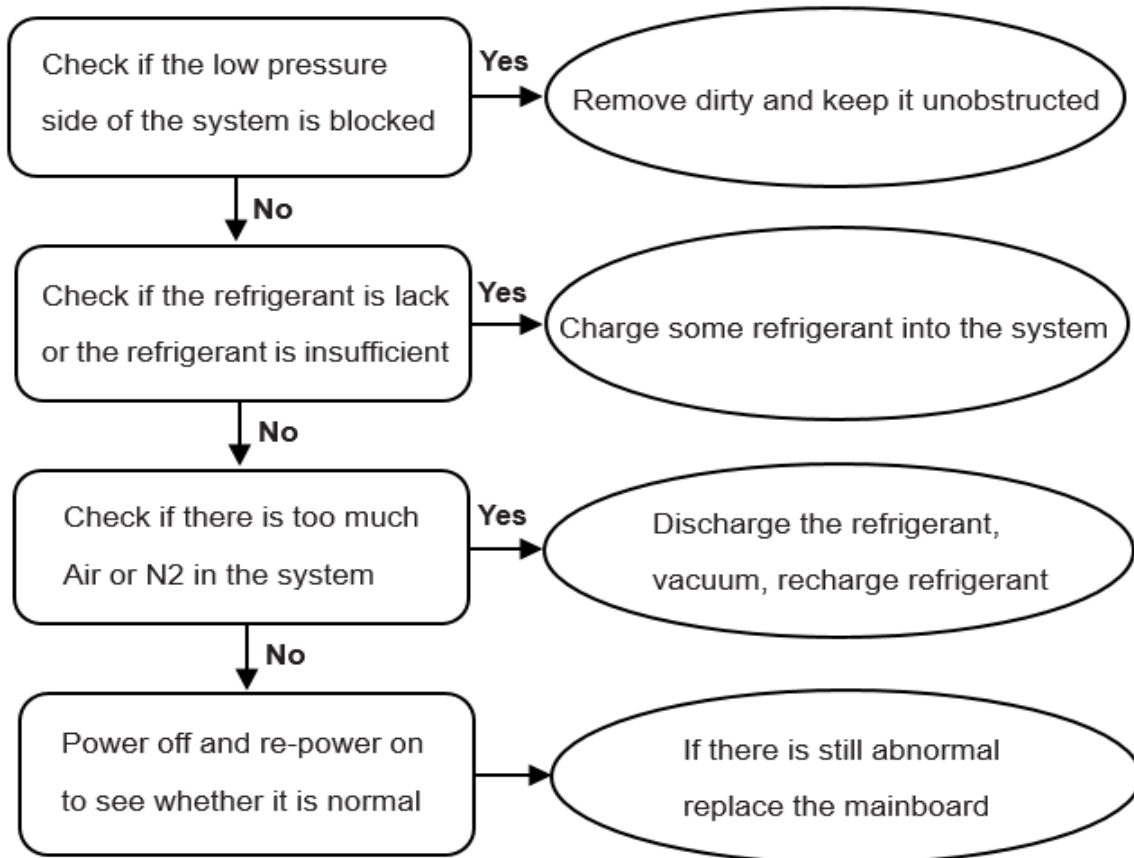

P5/H1 (T3 condenser sensor high temp protection)

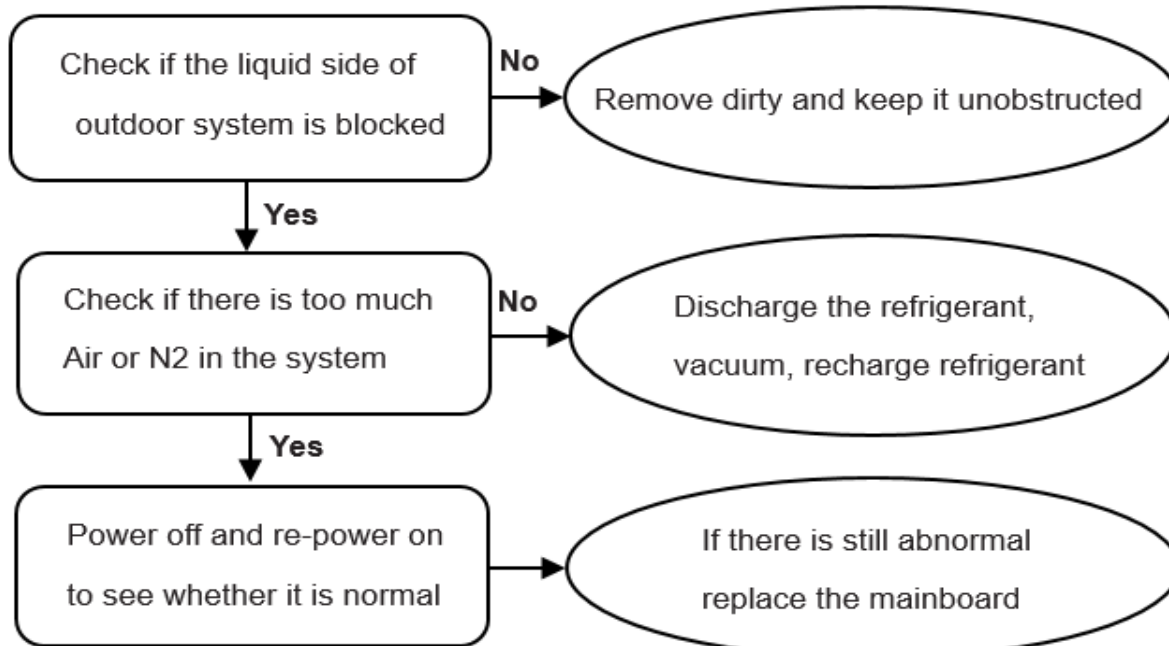

Residential Split Troubleshooting (cont'd)

P6 (IPM module protection)

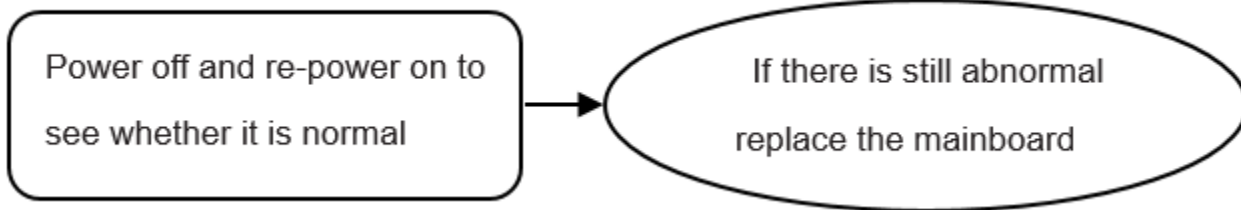

P8/H4 (IPM high temperature protection)

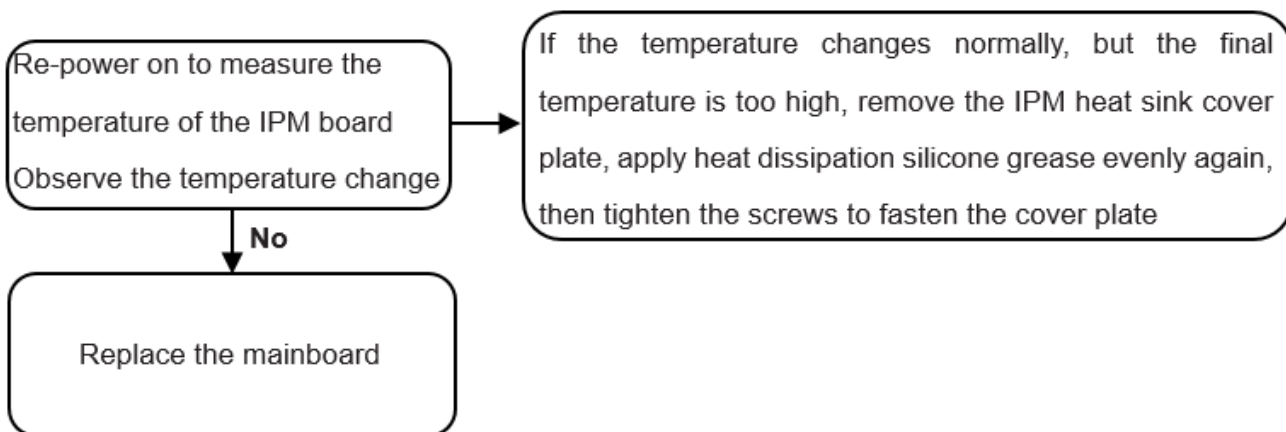

**IPM heat sink cover plate
should be fastened**



Residential Split Troubleshooting (cont'd)

P9 (DC fan motor error)

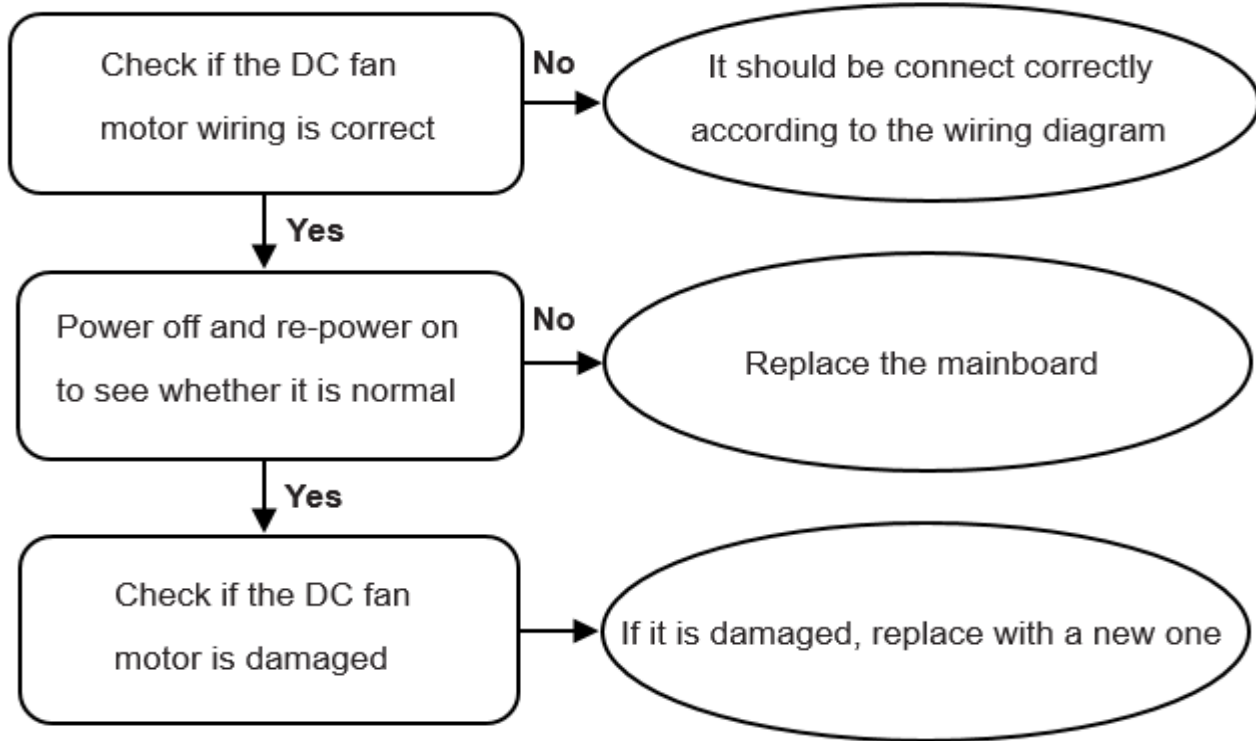

**The DC fan motor
wire interface**

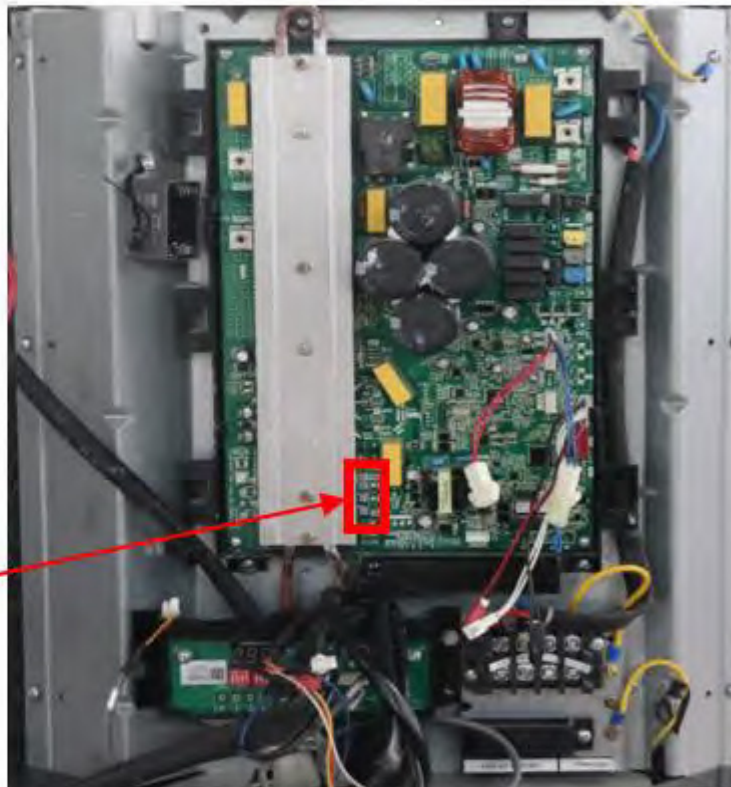

Residential Split Troubleshooting (cont'd)

P12/H7 (Wet operation error)

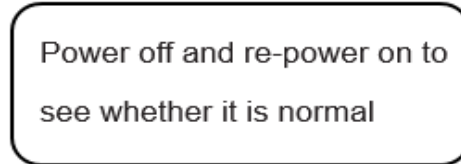

P13/H3 (High pressure abnormal error-In heating mode)

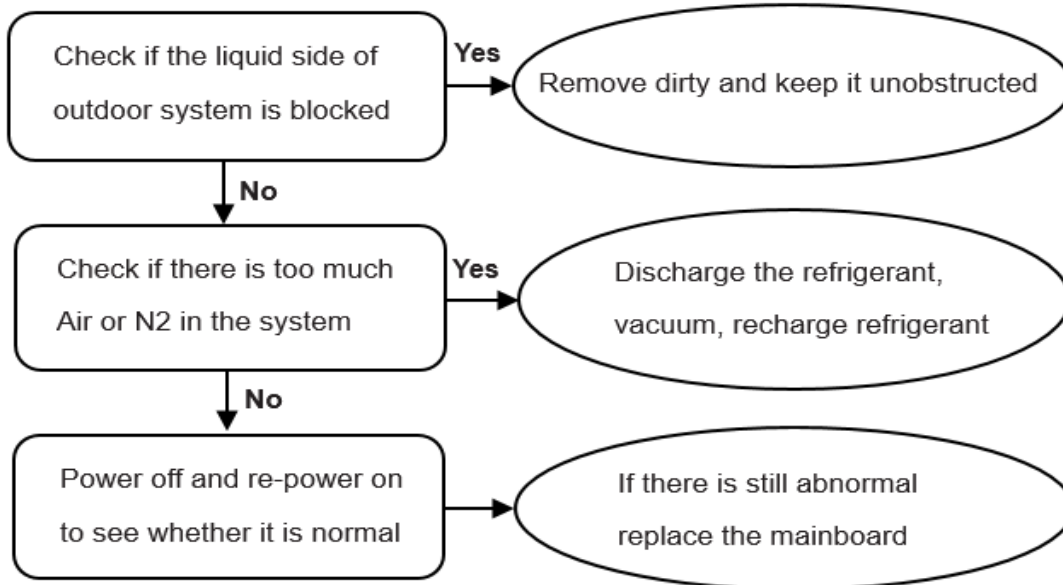

P14 (High compression ratio protection)

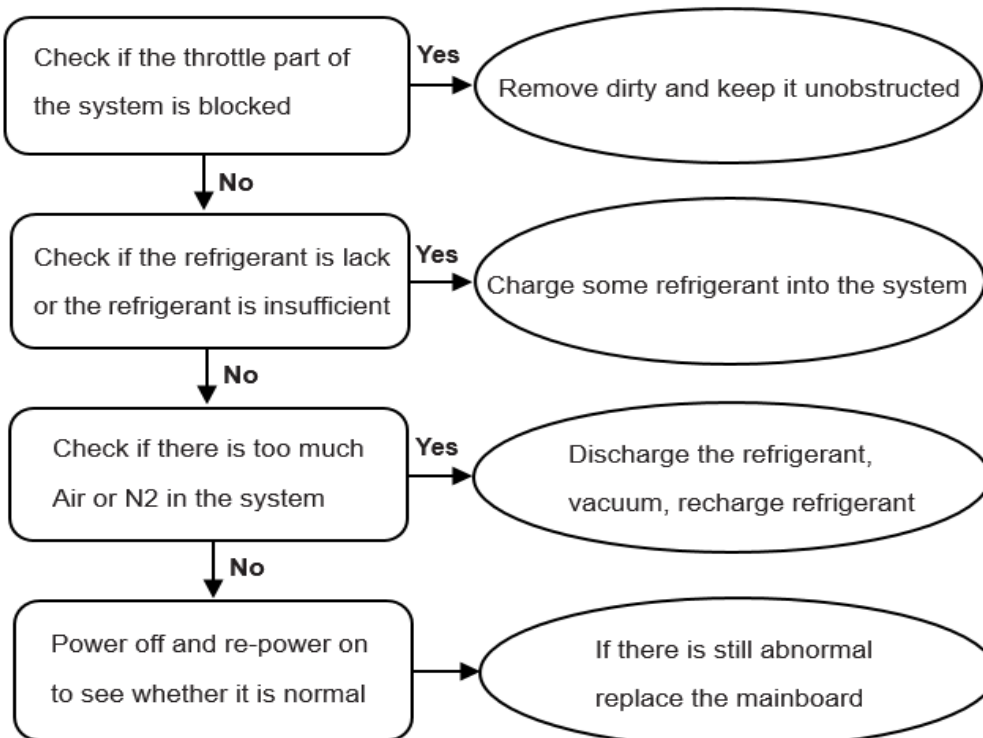

Residential Split Troubleshooting (cont'd)

P15 (Low compression ratio protection)

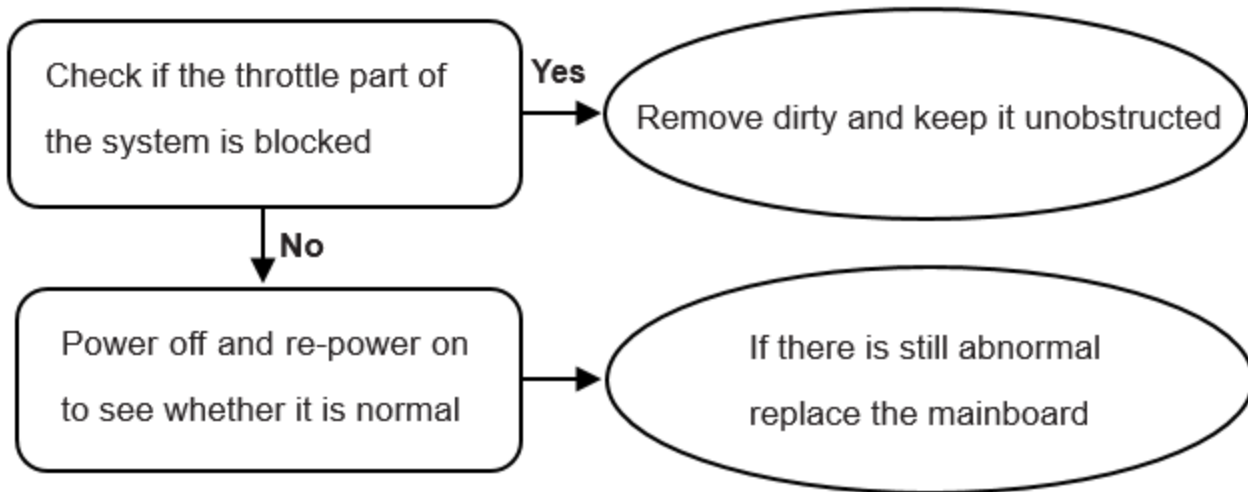

L1/L2 (DC cable bus low/high voltage protection)

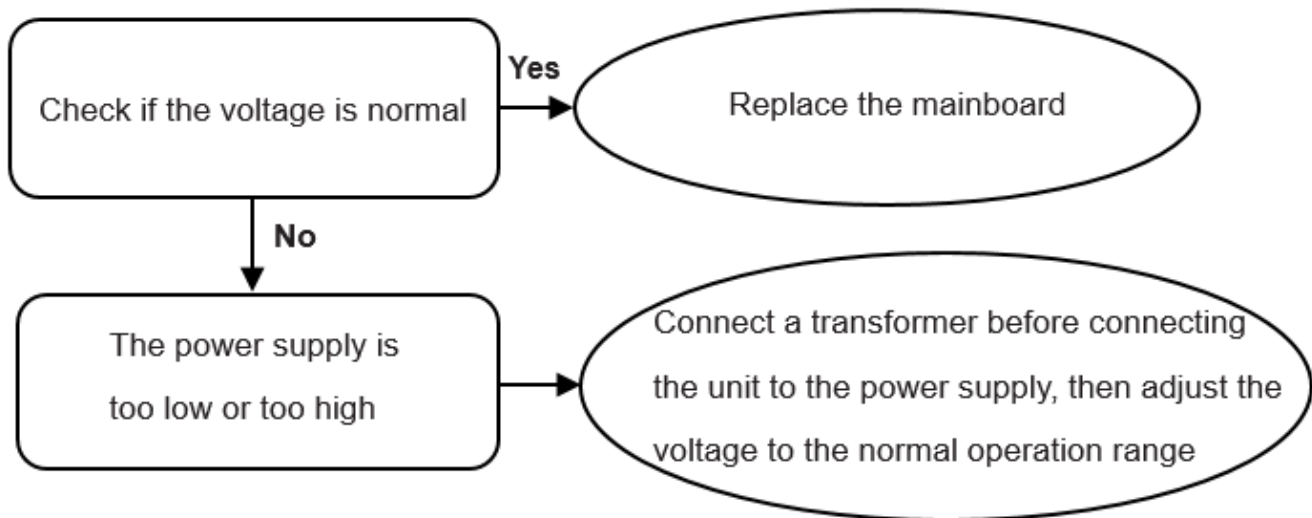

L4-L8 (IPM module subdivision protection)

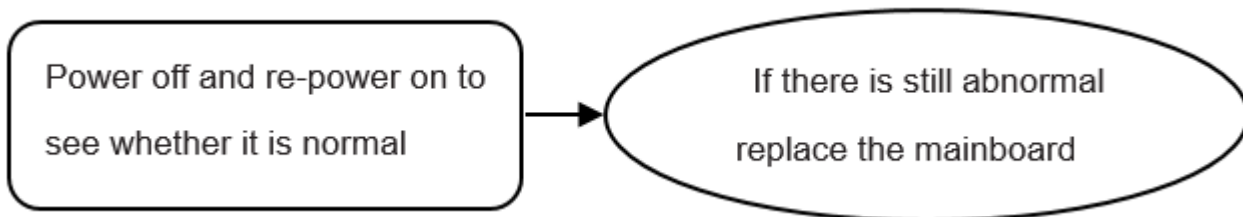

L9-LE (Frequency limitation protection, not error)

**SEE IOM-0035 O/M APPENDICES MANUAL FOR MORE
INFORMATION ON INSTALLATION AND SET UP OF
PERIPHERAL DEVICES**

